

# Street & Performance

## 2008 1/2 Catalog



### Complete Engines...

**www.  
hotrodlane  
.cc**



Ford  
"Your Parts Source"

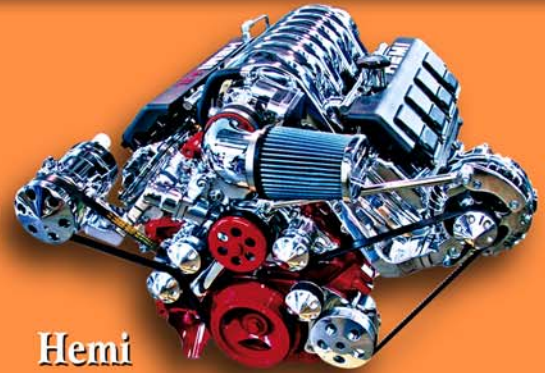

Hemi  
5.7 /345hp • 6.1/425hp • 392/540hp



LS-1 • LS-2 • LS-3  
LS-6 • LS-7 • 8.1

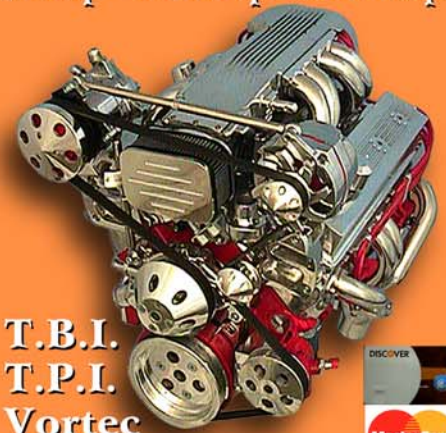

T.B.I.  
T.P.I.  
Vortec



S/B  
RamJet



B/B  
RamJet



LT-1  
LT-4



**Installation  
Instructions  
on DVD, Video,  
& Web.**

**"The Leader in Aluminum & Fuel Injection"**

...and **All**  
the Parts!



**Street &  
Performance, Inc.**

# 1 Hot Rod Lane, Mena, Ar. 71953  
Fx: 479-394-7113

**Ph:479-394-5711**

Web: [www.hotrodlane.cc](http://www.hotrodlane.cc)

Email: [sales@hotrodlane.cc](mailto:sales@hotrodlane.cc)



Check out the web for our latest **HOW-TO-PROJECTS** from the S&P Hot Rod Shop.

[www.hotrodlane.cc](http://www.hotrodlane.cc)



Blown LS-1 in a '39 Coast to Coast  
TPI in Nova



LS-2 / 6 Speed '69 Camaro  
DRIVE BY WIRE  
LS-1 / 6 Speed '68 Camaro



LS-1 / 4L60E '77 Chevy Pickup

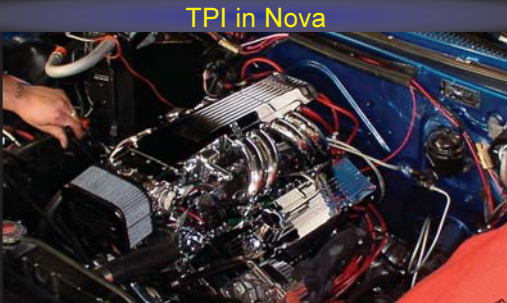

TPI in '66 Impala



TRI-5 LT-1 / 4L60E



LS-1 / 4L60E '56 Chevy



TPI into a '71 Chevy Pickup



5.3 Truck / 4L60E into a CJ



LS-1 / 6 Speed in a '70 Chevelle



LS-1 in a Coast to Coast



LT-1 in a '86 Chevy Pickup



5.7 HEMI in a '33 Dodge



LS-1 / 4L60E into a '65 Chevelle



LS-1 / 4L60E into a '87 Grand National



6.1 HEMI into a '68 GTX  
5.7 HEMI into a '70 Challenger

Visit our web site for these and many other step by step projects. Information on the web include how to install the engine, transmission, electrical, fuel systems, tuning and troubleshooting. The web also provides an **ONLINE TECH** page and video clips of our **Technical Data** and **Installation Videos**. These videos are available in **VHS** or **DVD**.



# we D R I V E what we sell!

Custom Polishing, Chroming and Thermal Barrier Coating available for your HOT ROD, MOTORCYCLE and custom parts.



Eddie Nault in final design of new "RamJet" Valve Covers



2 of 8 CNC Machining Centers

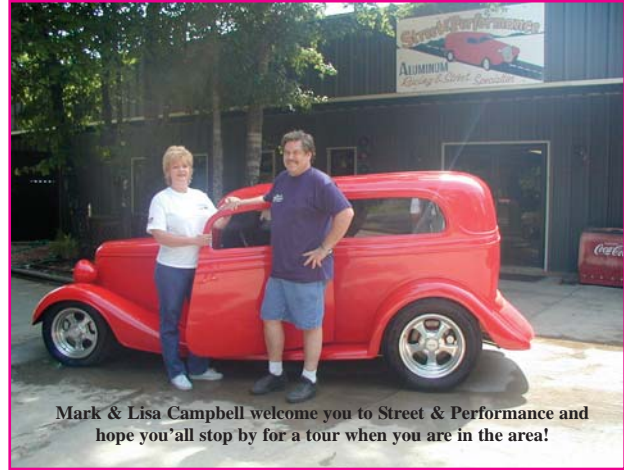

Mark & Lisa Campbell welcome you to Street & Performance and hope you'll stop by for a tour when you are in the area!



Partial view of final engine assembly

Another RamJet Intake coming from our Chrome Shop



One of three automatic CNC robotic polishing machines



Final assembly of the new "RamJet Injection"



Our new Coating Facility



Pouring of 713 aluminum alloy in the foundry

Individual and Club Tours welcomed. Come and see the Street & Performance Manufacturing Facility. Quality at its Best.



ABOUT STREET & PERFORMANCE





**1998 CENTURION CUSTOM CAB  
1998 LS1 CORVETTE MOTOR**

This particular setup is used as the company's test truck. It has been promoted at numerous hot rod events as well as traveling in several Hot Rod Power Tour. Seven Years later it is still a daily driver and test vehicle.



**1968 CAMARO - 502/502 S&P MULTI-PORT W/ 4L60E TRANSMISSION**

Owner: Danny & Tammy Deramus - of Street & Performance, Inc. The 1968 Camaro version was used in testing the 502 Crate Motor including computer testing for performance and driveability.



**1991 CAPRICE - 502 BB WITH  
BRODIX-1 HEADS W/COMPETITION CAM**

The 1991 Caprice Test Vehicle is set-up with a Comp Full Roller Cam Kit and with a performance 4L60 Transmission and used for testing modified Big Blocks.



**1990 GMC SIERRA EXTENDED CAB  
Z24 W/ INTERGRATOR GM TPI**

1990 SEMA Feature Vehicle, is now used as Street & Performance Test Truck for Small Block Tuned Port Development. 15 years of service, this is the truck that Mark drives home every night.

**SHIPPING INFORMATION**

**PRICES:** We reserve the right to change prices and company policies without notice. Depending on the customers method of payment, any additional costs will be charged to your MasterCard/Visa or balance due sent C.O.D..  
**PAYMENT:** Payment MUST be made in U.S. FUNDS ONLY! Personal checks are welcome, but please allow at least (21 days) for clearance of check from bank. For prompt service, you may use MasterCard/Visa (please be sure correct account number, expiration date, and mailing address of card are included). Cash-On-Delivery (C.O.D.) orders are welcome. But, must be paid by Cashiers Check, Certified Check, or Money Order. There will be an additional charge added to each order for shipping/handling per C.O.D. package.  
**SALES TAX:** State of Arkansas (only) residents must add 7% sales tax.  
**SHIPPING:** Shipping charges are based on weight and destination of package. A shipping/handling fee will be added to all orders shipped. Canadian and International shipments must be pre-paid or charged to your MasterCard/Visa.  
**DAMAGED CLAIMS:**

**U.P.S.:** Merchandise shipped via United Parcel Service must be kept in the original shipping carton for UPS inspection. Please contact your nearest UPS location should your shipment be damaged; they must do the inspection.

**U.S.P.S.:** Merchandise shipped via United States Postal Service must be kept in the original shipping carton for USPS inspection. Take the entire package of damaged goods to your local USPS. They will assist you in filing your damage claim using the proper forms. Please keep in mind when using the postal service, there is no way of tracking goods if the package should become lost.

Any claims for damaged goods, shortages or returns must be reported within (5 days) of receipt and a copy of the invoice must be provided. Contact your carrier immediately to notify the delivered goods were damaged in shipment. They will assist you in filing your damage claim using the proper forms or can instruct if different. **(do not ship directly back to S&P).**

**RETURN POLICY:** All items returned to Street & Performance, Inc. must be accompanied with a copy of the original invoice including instructions and reason for return pertaining to how you would like the return handled. Any shipping charges incurred are NOT refundable; all returns must be shipped prepaid. There will be no C.O.D. return shipments accepted! Refunds will be made within (30 days) of receipt of the returned goods. **ARTICLES MUST NOT BE DAMAGED, USED, DISFIGURED, OR MODIFIED IN ANY WAY!** On merchandise returned after 15 days, we reserve the right to deduct a 15% restocking fee from the refund.

**SPECIAL ORDER POLICY:** Special order requests (parts that are not a stock item) may be made. Thus, they are non-returnable if the part is a non-stocked item in which may require up to full payment in advance before ordering; special order charges may apply.

**BACK ORDERED ITEMS:** Street & Performance, Inc. carries a large inventory of items; we do our best to keep all items in stock. Occasionally, we will be out of stock on an item. Should this occur on your order, back ordered items will be listed in the back order column noted on your invoice copy. Back ordered items are shipped within (3 weeks) or no later than (8 weeks) for custom parts from the initial order.

**WARRANTY/DEFECTS:** Street & Performance, Inc. shall not be responsible for cost of removal, installation, or incidental charges incurred as a result of parts alleged failure or inability. The company shall not be liable for any special, indirect, incidental, or consequential damages. Our responsibilities are limited to placement of defective items.

**STREET & PERFORMANCE PRICES ARE SUBJECT TO CHANGE WITHOUT NOTICE!**



**1986 Chevrolet / Dually "For Towing"**  
S&P's shop trucks using the 454 BBC Motor with S&P BB Multi-Port Fuel Injection Unit.



**1981 Chevy 1-Ton "Hauler"**  
Larry Sanders, Chrome Shop Foreman of S&P, dropped in the 454 BBC Motor including the S&P BB Multi-Port Fuel Injection Unit.



**1989 Chevrolet / 1500 Series**  
This is one of S&P's shop trucks using the 1993 LT1 Motor with 4L60 Transmission.



**Judy Sanders 78 Ford Test Truck**  
Late Model 5.0 E.F.I. Truck Engine for testing Ford fuel injections

**ORDERING INFORMATION**

**For Tracking #'s or C.O.D Totals  
Please Call (479) 394-9255**

**RECEIVING INFORMATION**

**Please Call (479) 394-2391**  
Phone Numbers are direct lines and will provide you with faster service.

At Street & Performance, Inc., we do our utmost to provide the highest quality parts in the industry at a reasonable price. We are well known for our strong customer support and excellent service. If you are unable to locate parts for your particular application in this catalog, please give us a call. We specialize in the unique, and our team of professionals will be more than happy to assist you. The staff at Street & Performance, Inc. would like to extend our gratitude to each of you who order your parts from us or your authorized S&P Dealer. Watch for new products and developments on our Web Site [www.hotrodlane.cc](http://www.hotrodlane.cc).

The Street & Performance Catalog is Designed by Street & Performance and Street & Performance Design. Digital Photography used a Ricoh RDC-2 Olympus C-2020Z, Olympus C-4000 and a Canon 20D. Typesetting, Graphics and Photography by Rick Maechler, and Dale Powell of Powell Advertising. Copyright 2005. No part of this publication may be reproduced in any fashion, without the expressed, written permission of Street & Performance Please excuse our partial Part Number format. We are in the process of assigning new part Numbers.



# HELP US HELP YOU

Check List for Ordering from the Street & Performance. Catalog Street & Performance accepts MasterCard, Visa, and American Express as forms of payment for your parts orders. COD UPS orders are cashiers check or acceptable money order only.

**Helpful Information:**

Year of Vehicle	Type of Shipping
Year and Model of Engine	Form of Payment
Front suspension	Shipping and Billing
Address	

Our Part Numbers are Currently being finalized. If you use a part number from this catalog please include a (n) for natural finish, (p) for polished and (c) for chrome

When Calling about your order or backorder; Please have the following information available to better serve your needs. **TRACKING (479) 394-9255 RECEIVING (479) 394-2391**

- \* Customer Number
- \* Date of Order
- \* Invoice Number
- \* Method of Shipment
- \* Customer phone Number, Fax Number & E-mail addresses
- \* Type of Credit Card, Credit Card Number and Expiration Date
- \* Shipping Address if different from Credit Card Mailing Address
- \* Have your catalog available when calling

Visit our Website and click on New Hot Rod Shop for our latest projects.

TPI / LT1 Aluminum Elbow with couplers



Natural. . . . . \$ 103.95  
Polished. . . . . \$ 134.95  
Chrome. . . . . \$ 165.95

**NEW**

Pg. 93



Aluminum LS1 Intake Manifolds



Now headers for 5.7 6.1 A / B & E body cars



Torque Converter Lock-up Relay Kit. \$20.95

For use with hydraulic brake switch.



See Pg101

S/B Jaguar Headers Available in Polished, Stainless Steel, Coated.



Coated \$482.95 Polished \$565.95

Alt. / AC 2" Riser Blocks \$23.95 Pol ea. \$36.95 Chrome ea.



NOVA Headers



SB LT1 Also LS1

New S&P 99-UP LS-1/LS-6 Aluminum Valve Covers for remote coil applications. Smooth, Z06, LS1 designs in stock. With or without PCV Breather Holes. Comes complete with stainless steel bolts and GM gaskets. Will Clear Roller Rocker Arms. Custom Designs are available.

Available in Chrome See Page 55



SB Ram Jet Alum. Dress Up Covers (1) Polished Grooved.....\$ 124.95 (2) Polished Deep Ribbed....\$ 134.95

Custom Tail Pipe Hangers See Pg.130



Call for details

HydroVac PB/PS Reservoir w/ Two AN-6 Returns Polished \$144.95 Chrome \$175.95 with Bracket.



Polished Chrome



Billet Hose End Covers Page 124

New Bracket Kit for Small Block Ram Jet & 87 up cast iron heads. NO DRILLING REQUIRED Also works with T.P.I, Tunnel Rams, Two Fours and Three Deuces



Big Block Low Pass. Side Air Bracket. SWP. Must use water pump with modified suction side



Polished.....\$68.95 Chrome.....\$82.95

LS-7 Headers For Several Different Applications





Aluminum Radiator's & Acc. Pg. 124-125

Visit our Website and click on New Hot Rod Shop for our latest projects.



For all your Chassis needs.

A/C Compressors & ACC. Pg. 49

Water Neck Pg. 22, 25, 46, 72, 80, 129,

Idler Pulley Pg. 12

Aluminum & Chrome Water Pump Pg. 22,28,29,72,87,131,134,136

Serpentine Pulleys S/B SWP....Pg. 12,24 S/B Blower Pg.18 B/B.....Pg. 112 B/B Blower Pg. 114 Ford.....Pg. 129-137 Mopar.....Pg. 149

Aluminum Pulley S/B V-Belt SWP. Pg. 8 S/B LWP.....Pg. 9 S/B Blower.....Pg. 18 B/B SWP.....Pg. 106-108 B/B Blower.....Pg. 114 Ford.....Pg. 130 Mopar.....Pg. 149 Buick.....Pg. 142

Power Steering Pg. 42-45

Freeze Plug Covers Pg. 46-121

Injection Unit's Big Block.....Pg. 118-120 Small Block.....Pg. 55-61 Ford.....Pg. 126-127 Ram Jet Small Block...Pg. 54-57 Ram Jet Big Block.....Pg. 118 Small Block Ram Port.Pg. 59

Polished or Chrome Intake SB / BB .....Pg. 40 LS.....Pg. 93 Ford.....Pg. 127 Injection Acc. Pg. 62-65 Rear End Cover Pg. 141



Valve Covers Small Block.....Pg. 36-38 LS.....Pg. 101 Big Block.....Pg. 123 Ford.....Pg. 131-134 Custom Design...Pg. 36-38

Aluminum P.C.V & Breather Page. 36-39

Spark Plug Wire Small Block.....Pg. 37-39 LT1.....Pg. 73 LS.....Pg. 98 Big Block.....Pg. 123 Ford.....Pg. 127

Headers Stainless Steel & Thermal Coated S/B Chevy.. Pg.50-53 LT1.....Pg.78 LS.....Pg. 99 Big Block.....Pg. 122 Ford.....Pg. 132 Mopar.....Pg. 149,158 Alternator.....Pg. 48

Buick.....Pg. 149 Oldsmobile..... Pg. 150

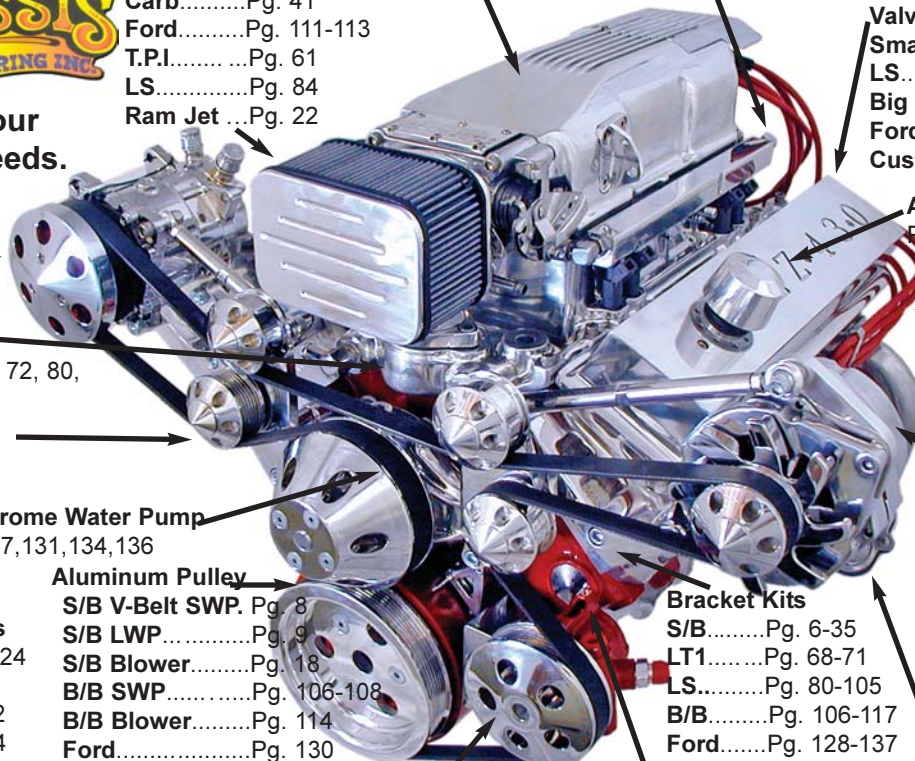

There was a 13 week in show featured on Mother's Polish Car Show Series on a ground up build of two '57 Chevs built at S&P. The Red car has a LS-1 with a 4L60E transmission. The Green and Silver car has a LS-7 in front of a T-56 6 speed transmission. A free DVD can be yours by calling S&P. See our web site for links to the manufacturers involved in the Street & Performance TRI-FIVE ALIVE projects.





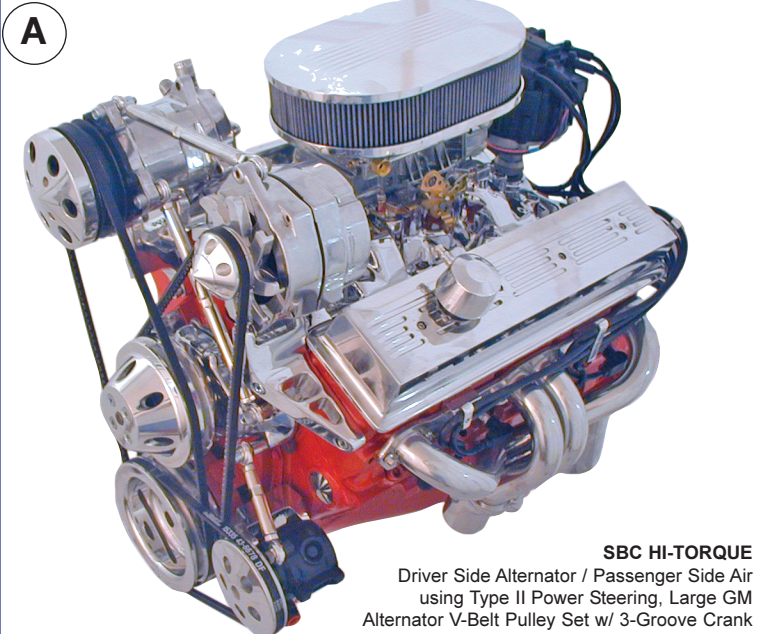

A

**SBC HI-TORQUE**  
Driver Side Alternator / Passenger Side Air  
using Type II Power Steering, Large GM  
Alternator V-Belt Pulley Set w/ 3-Groove Crank

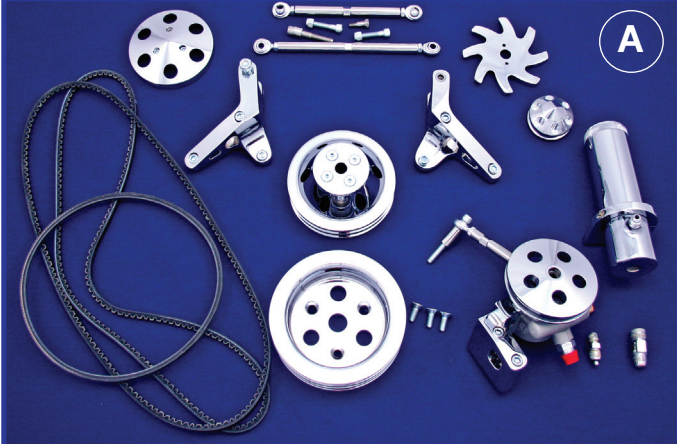

A

<b>Part #</b>	<b>HI-TORQUE BRACKET KITS V-BELT</b> Complete kit with brackets & bars, 3 groove crank pulley, 2 groove wp pulley and 1 groove alternator pulley. Type II power steering with remote reservoir, fittings & belts <b>(Alternator fan and Compressor cover optional)</b>	Natural \$1019.95 Polished \$1051.95 Chrome \$1198.95
---------------	---	---

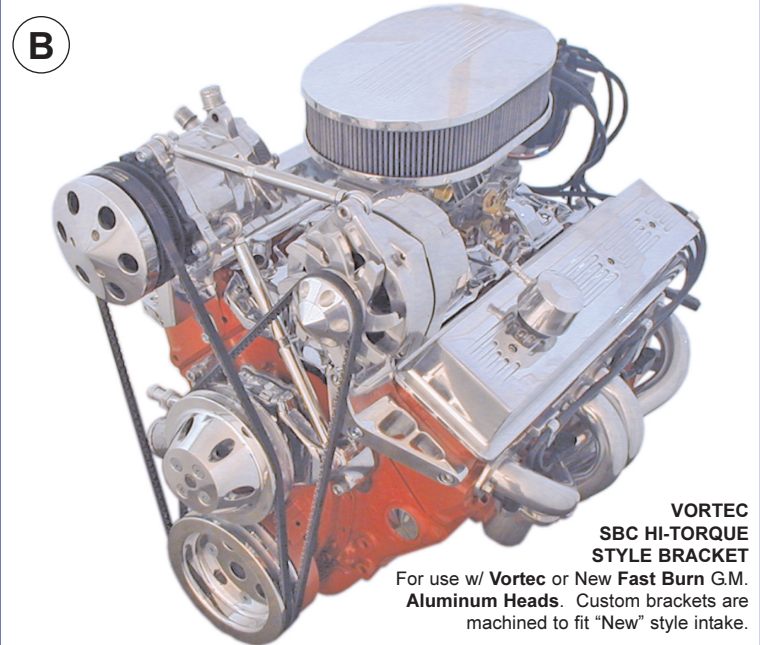

B

**VORTEC SBC HI-TORQUE STYLE BRACKET**  
For use w/ Vortec or New Fast Burn G.M. Aluminum Heads. Custom brackets are machined to fit "New" style intake.



B

<b>Part #</b>	<b>HI-TORQUE BRACKET KITS V-BELT</b> Complete kit with brackets & bars, 3 groove crank pulley, 2 groove wp pulley and 1 groove alternator pulley & belts <b>(Alternator fan and Compressor cover optional)</b>	Natural \$ 522.95 Polished \$ 544.95 Chrome \$ 625.95
---------------	---	---

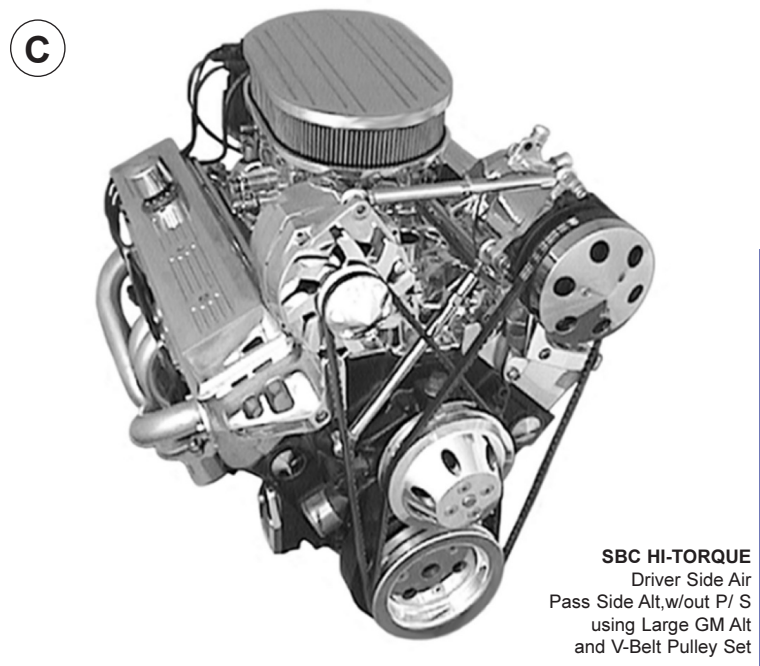

C

**SBC HI-TORQUE**  
Driver Side Air  
Pass Side Alt, w/out P/S  
using Large GM Alt  
and V-Belt Pulley Set

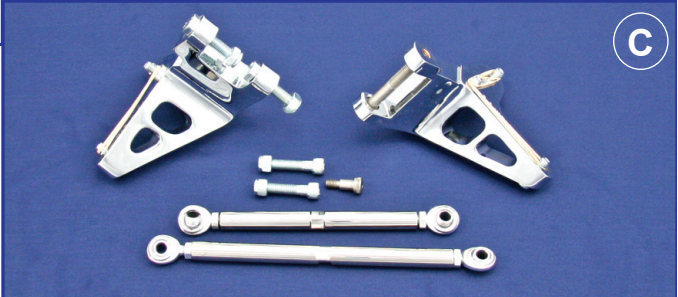

C

<b>Part #</b>	<b>HI-TORQUE BRACKET KITS V-BELT</b>	<b>Natural</b>	<b>Polish</b>	<b>Chrome</b>
	<b>(Inc: Brackets, Adjusting Bars and Bolts)</b>			
10109001	Driver Side Alt / Passenger Side Air Kit	280.95	302.95	322.95
12109001	Driver Side Alt / Passenger Side Air Kit (Vortec)	280.95	302.95	322.95
10109002	Passenger Side Alt / Driver Side Air Kit (SB only)	298.95	312.95	334.95
10109003	D/Side Alt Kit w/ 10 O'Clock Adap & Bar	167.95	177.95	199.95
12109003	D/Side Alt Kit Only w/ 10 O'Clock Adap & Bar (Vortec)	167.95	177.95	199.95
10109004	Pass Side Alt Kit w/ 2 O'Clock Adap & Bar (SB/Vortec)	172.95	183.95	204.95
	<b>HI-TORQUE BRACKETS (Bolts Included)</b>			
10102001	Driver Side Alt Bracket	86.95	97.95	108.95
12102001	Driver Side Alt Bracket (Vortec)	86.95	97.95	108.95
10102002	Passenger Side Alt Bracket	92.95	102.95	113.95
10102004	Driver Side Air Bracket	92.95	102.95	113.95
10102006	Passenger Side Air Bracket	86.95	97.95	108.95
12102006	Passenger Side Air Bracket (Vortec)	86.95	97.95	108.95



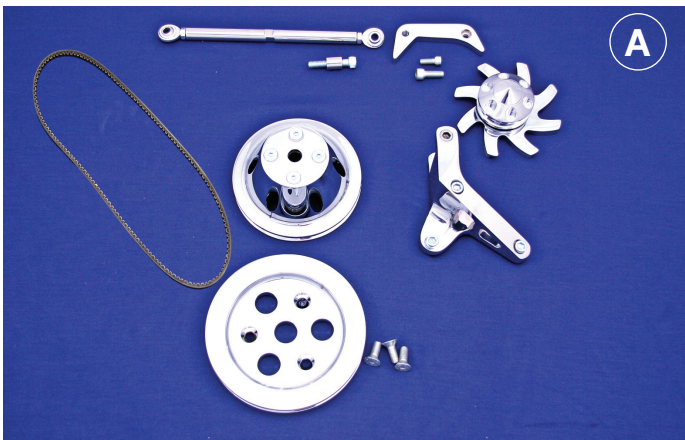

A

Part #	<b>HI-TORQUE BRACKET KITS V-BELT</b> Complete kit with brackets & bars, 1 groove crank pulley, 1 groove wp pulley and 1 groove alternator pulley (Alternator fan optional)	Natural \$ 384.95 Polished \$ 396.95 Chrome \$ 477.95
--------	---	---

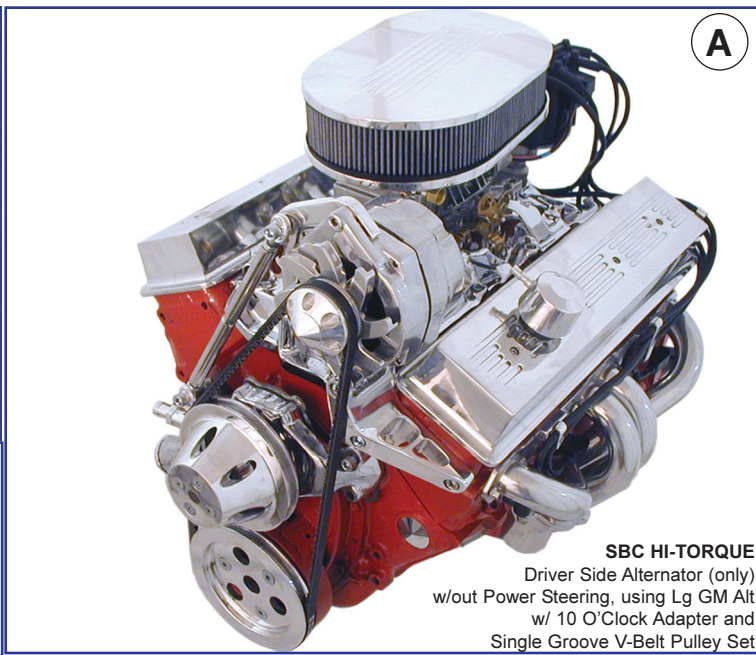

A

**SBC HI-TORQUE**  
Driver Side Alternator (only)  
w/out Power Steering, using Lg GM Alt  
w/ 10 O'Clock Adapter and  
Single Groove V-Belt Pulley Set

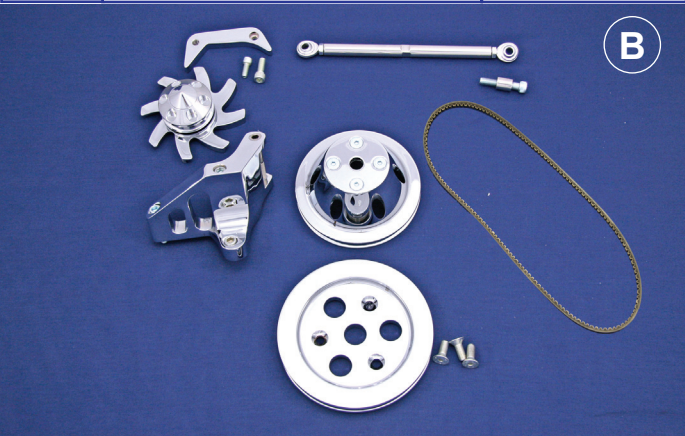

B

Part #	<b>HI-TORQUE BRACKET KITS V-BELT</b> Complete kit with brackets & bars, 1 groove crank pulley, 1 groove wp pulley and 1 groove alternator pulley (Alternator fan optional)	Natural \$ 390.95 Polished \$ 401.95 Chrome \$ 482.95
--------	---	---

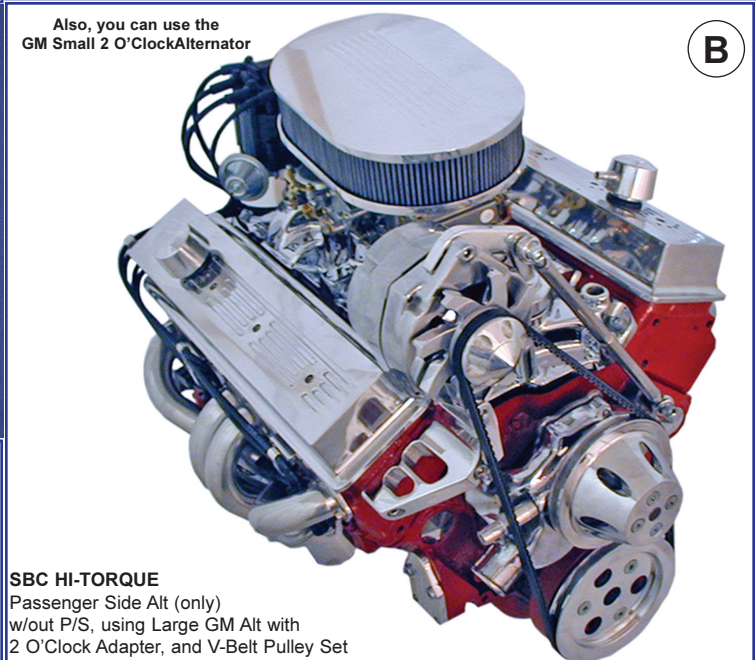

B

Also, you can use the  
GM Small 2 O'Clock Alternator

**SBC HI-TORQUE**  
Passenger Side Alt (only)  
w/out P/S, using Large GM Alt with  
2 O'Clock Adapter, and V-Belt Pulley Set

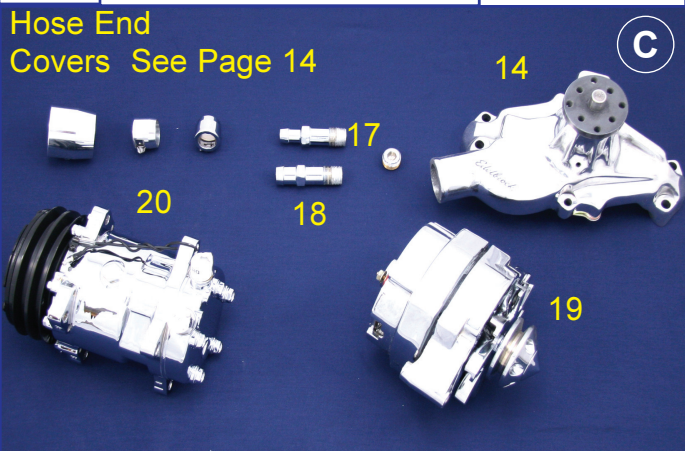

C

Hose End Covers See Page 14



Part #	HI-TORQUE V-BELT ACCESSORIES	Natural	Polish	Chrome
10000402	14. Alum Edelbrock SWP Standard Rotation . . . .	215.95	290.95	N/A
10000401	15. GM Steel Chrome Standard Rotation . . . . .	-	-	135.95
10000403	16. Alum Vette Rev. Rotation 3/4" Pilot W/P . . . .	151.95	204.95	-
00000420	17. Long 1/2" pipe to 5/8" Hose Bib . . . . .	N/A	19.49	21.95
00000421	18. Long 1/2" pipe to 3/4" Hose Bib . . . . .	N/A	19.49	21.95
01010901	19. Alternator V-Belt . . . . .	15.95	-	-
01052625	20. Air Compressor V-Belt . . . . .	18.95	-	-
<b>POWER STEERING KITS &amp; ACCESSORIES</b> Includes: Bracket, Pump, Pulley & SS Adjusting Bar & Bolts				
10009101	22. SB Type I P/S Kit (for 1 or 2 Gr. Crank) . . . . .	290.95	302.95	322.95
10009102	23. SB Type II P/S Kit (for 3 Gr. Crank) . . . . .	290.95	302.95	322.95
00000105	"New" Aluminum Type II P/S Pump (Only) . . . . .	135.95	189.95	275.95
00009402	24. S&P Alum Overflow Tank w/ Bracket . . . . .	-	144.95	172.95
00009400	25. S&P Alum P/S Reservoir w/ Bracket . . . . .	-	144.95	172.95
01033625	26. Power Steering V-Belt . . . . .	14.95	-	-
00000424	27. 1/2" to AN8 . . . . .	-	17.49	20.49
00000441	28. 16mm O-ring to AN6 . . . . .	-	17.49	20.49

**Alternator Fan and Pulley sold separately.**  
**Water Pumps available in Natural or Polished.**  
**Compressors available in R-12 or R-134A.**  
**Rear Exit Compressor Optional.**  
**Unused Compressor Mounts Removed Optional**





10109050

Small Block Single Groove Short Water Pump Pulley Set (Aluminum Alt Fan Optional)



10109051

Small Block Double Groove Short Water Pump Pulley Set (Aluminum Alt Fan Optional)



10109052

Small Block Triple Groove Short Water Pump Pulley Set (Aluminum Alt Fan Optional)

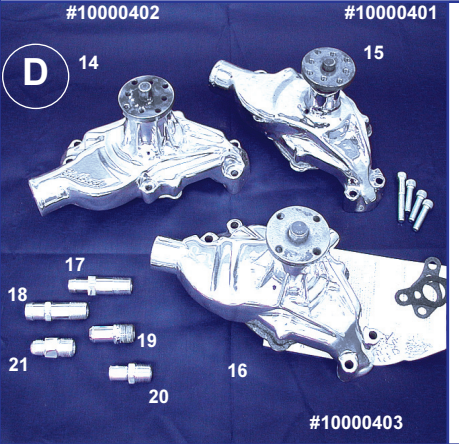

#10000402 #10000401

#10000403

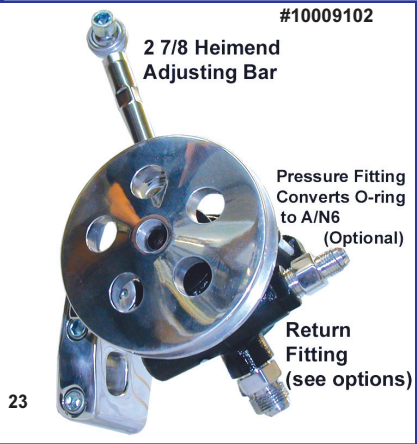

2 7/8 Heimend Adjusting Bar

Pressure Fitting Converts O-ring to A/N6 (Optional)

Return Fitting (see options)



TYPE II Power Steering Kit. Runs on outside third groove. SWP

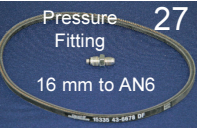

Pressure Fitting 27 16 mm to AN6

Belt # 01033625

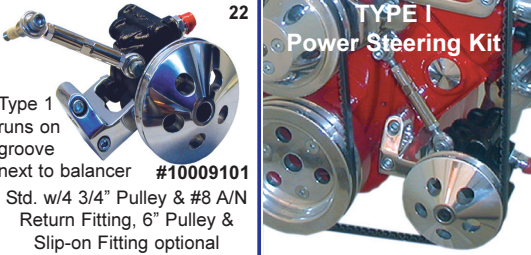

TYPE I Power Steering Kit

Type 1 runs on groove next to balancer #10009101 Std. w/4 3/4" Pulley & #8 A/N Return Fitting, 6" Pulley & Slip-on Fitting optional

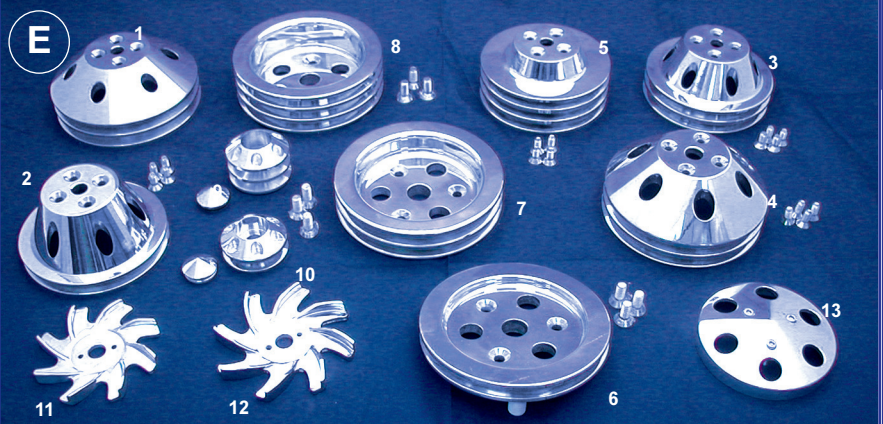

E



F

#00009400

#00009402

#00000401

Part#	V-BELT PULLEY W/BOLTS	Natural	Polish	Chrome	Part #	HI-TORQUE V-BELT ACCESSORIES	Natural	Polish	Chrome
	<b>HI-TORQUE V-BELT PULLEY SETS</b>								
10109050	A. 1-Groove Pulley Set (Crank, W/P, and Alt)	N/A	202.95	261.95	10000402	14. Alum Edlebrock SWP Standard Rotation	215.95	290.95	N/A
10109051	B. 2-Groove Pulley Set (Crank, W/P, and Alt)	N/A	207.95	266.95	10000401	15. GM Steel Chrome Standard Rotation . . . .	-	-	135.95
10109052	C. 2-Groove Pulley Set (3-Gr. Crank, 2 Gr. W/P and 1 Gr. Alt) . . . . .	N/A	229.95	293.95	00000403	16. Alum Vette Rev. Rotation 3/4" Pilot W/P . . . . .	150.95	204.95	-
	<b>INDIVIDUAL V-BELT PULLEYS</b>				00000420	17. Long 1/2" pipe to 5/8" Hose Bib . . . . .	N/A	19.49	21.49
00100085	1. SBC SWP 2-Groove W/P Pulley 6 7/8 dia . . . . .	N/A	92.95	115.95	00000421	18. Long 1/2" pipe to 3/4" Hose Bib . . . . .	N/A	19.49	21.49
00100086	2. SBC SWP 1-Groove W/P Pulley 6" dia . . . . .	N/A	92.95	115.95	00000422	19. Short 1/2" pipe to 3/4" Hose Bib . . . . .	N/A	17.49	20.49
00100087	3. SBC SWP 2-Groove W/P Pulley 6" dia . . . . .	N/A	92.95	115.95	00000423	20. Short 1/2" pipe to 5/8" Hose Bib . . . . .	N/A	17.49	20.49
00100088	3a.SBC SWP 2-Groove W/P Pulley 5 3/4 dia . . . . .	N/A	102.95	122.95	00000424	21. 1/2" Pipe to A/N #8 . . . . .	N/A	17.49	20.49
	***For Blower Motor not Pictures***				10009101	<b>POWER STEERING KITS &amp; ACCESSORIES</b>			
10100090	4. Vette 2-Gr. W/P 3/4" Pilot & Wide Bolt Pat. . . . .	N/A	102.95	122.95		Includes: Bracket, Pump, Pulley & SS Adjusting Bar & Bolts			
10100091	5. SBC SWP 3-Groove W/P Pulley 5/8" . . . . .	N/A	118.95	140.95	10009101	22. SB Type I P/S Kit (for 1 or 2 Gr. Crank) . . . . .	290.95	302.95	322.95
10100092	6. SBC SWP 1-Groove Crank Pulley 6 7/8" dia . . . . .	N/A	75.95	100.95	10009102	23. SB Type II P/S Kit (for 3 Gr. Crank) . . . . .	290.95	302.95	322.95
10100093	7. SBC SWP 2-Groove Crank Pulley 6 7/8" dia . . . . .	N/A	81.95	105.95	10009103	24. SB Type II P/S Kit (new Pump & Plastic Res)	382.95	398.95	430.95
10100094	8. SBC SWP 3-Groove Crank Pulley 6 7/8" dia . . . . .	N/A	102.95	132.95	00000105	"New" Aluminum Type II P/S Pump (Only) . . . . .	135.95	189.95	275.95
00100031	9. 2-Gr. Alternator Pulley . . . . .	N/A	46.95	56.95	01033625	Type II Power Steering Belt . . . . .	14.95	-	-
00100030	10. 1-Gr. Alternator Pulley . . . . .	N/A	35.95	46.95	00009400	25. S&P Alum P/S Reservoir w/ Bracket . . . . .	-	135.95	168.95
00000007	11. Alum Alternator Fan (Small) . . . . .	N/A	43.95	53.95	00000401	26. GM Plastic P/S Reservoir . . . . .	51.95	-	-
00000008	12. Alum Alternator Fan (Large) . . . . .	N/A	43.95	53.95	01049625	Alt V-Belt - Kit #10109001 & 10109002 . . . . .	15.95	-	-
00000011	13. 508 Compressor Front Cover . . . . .	N/A	53.95	65.95	01052625	Air V-Belt - Kit #10109001 & 10109002 . . . . .	18.95	-	-
00000704	GM Alternator 1-Wire 90 amp . . . . .	97.95	146.95	161.95	10109105	Type II P/S Bar Kit . . . . .	N/A	53.95	N/A
00110509	508 A/C Compressor 134 Serpentine . . . . .	226.95	280.95	334.95	01033625	27. Power Steering Belt . . . . .	14.95	-	-
						28. New Self Contained Alum PS Reservoir . . . . .	N/A	289.95	341.95



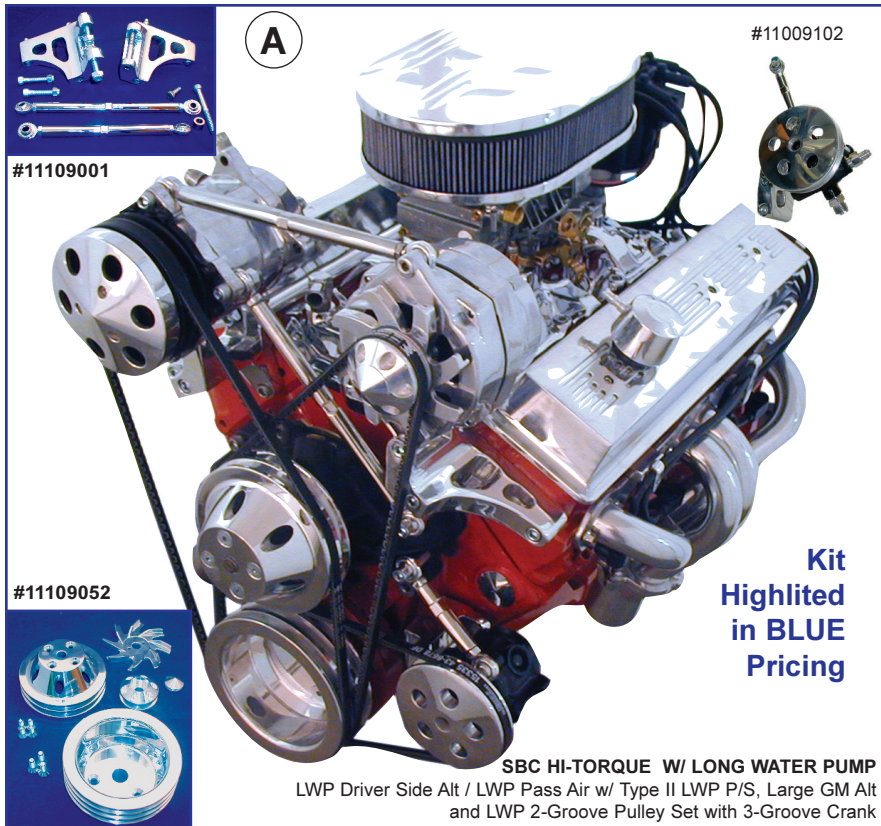

#11009102

A

Kit  
Highlighted  
in BLUE  
Pricing

SBC HI-TORQUE W/ LONG WATER PUMP  
LWP Driver Side Alt / LWP Pass Air w/ Type II LWP P/S, Large GM Alt  
and LWP 2-Groove Pulley Set with 3-Groove Crank

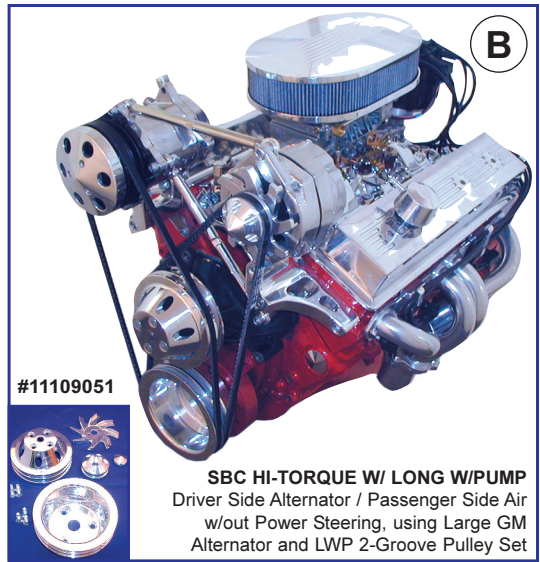

B

#11109051

SBC HI-TORQUE W/ LONG W/PUMP  
Driver Side Alternator / Passenger Side Air  
w/out Power Steering, using Large GM  
Alternator and LWP 2-Groove Pulley Set



C

Long Water Pump Pulleys

Part#		Polished	Chrome
00000007	1. Lg. Alum Alt Fan	43.95	55.95
00000008	2. Sm. Alum Alt Fan	43.95	55.95
00001001	3. Alum 2-Gr. LWP Pulley	97.95	122.95
11001003	4. Alum 2-Gr. LWP Crank Pulley	112.95	159.95
11001004	5. Alum 3-Gr. LWP Crank Pulley	132.95	181.95
00001002	6. Alum 1-Gr. LWP W/P Pulley	92.95	115.95
00100032	7. Alum 2-Gr. Alt Pulley	46.95	56.95
00100030	8. Alum 1-Gr. Alt Pulley	35.95	46.95
00000020	9. Alum Alternator Buttons	8.95	11.49

Long Water Pump Brackets S/B Engine

Part #	HI-TORQUE LONG W/PUMP BRACKET KITS (Includes: SS Adjusting Bar & Bolts)	Natural	Polished	Chrome
11109001	Driver Side Alternator / Passenger Side Air Bracket Kit	290.95	312.95	355.95
11109003	Driver Side Alternator (Only) Bracket Kit (Brkt, 10:00, Bar) HI-TORQUE LONG W/PUMP ALT AND AIR BRACKETS	194.95	204.95	215.95
11102001	Driver Side Alternator (Only) Bracket	92.95	102.95	124.95
11102006	Passenger Side Air Bracket	92.95	102.95	124.95
00000001	10 O'Clock Alternator Adapter Bracket for Driver Side	N/A	26.95	38.95
00000002	2 O'Clock Alternator Adapter Bracket for Passenger Side HI-TORQUE LONG W/PUMP ADJUSTER BAR KIT	N/A	26.95	38.95
11109102	LWP SS Heim End Alt to Air Top Bar	N/A	53.95	N/A
11109113	LWP SS Heim End Bar Air to W/P	N/A	53.95	N/A
11109114	LWP SS Heim End Bar Alt to W/P	N/A	53.95	N/A
11109115	2 - LWP SS Heim End Bars Alt & Air	N/A	107.95	N/A
Bottom Rt	***Polished SS Heim Ends (Add Per Bar)	N/A	12.95	N/A
	HI-TORQUE LONG W/PUMP ACCESSORIES			
11109051	2-Gr. Pulley Set (2-Gr. Crank, W/P, and Alt.)	N/A	236.95	317.95
11109052	3-Gr. Pulley Set (3-Gr. Crank, W/P, and Alt.)	N/A	256.95	339.95
11009102	SB LWP Type II Power Steering Kit for V-Belt	292.95	356.95	350.95
11009103	SB LWP Type II P/S Kit w/New Pump & Plastic Reservoir	376.95	398.95	430.95
00009400	Aluminum Power Steering Reservoir w/ Bracket Kit	N/A	135.95	172.95
01048625	Alt V- Belt LWP	15.95	-	-
01052625	Air V-Belt LWP	18.95	-	-
01033625	V-Belt for Power Steering Type II	14.95	-	-

#11109052

D



Alt  
Fan is  
Optional  
Long Water  
Pump w/ 2 Gr.  
Water Pump  
Pulley  
and 3-Gr.  
Crank Pulley  
used w/  
Alternator/Air,  
And Type II  
Power Steering

#11109051

F



Alt  
Fan is  
Optional  
Long Water Pump  
w/ 2 Gr.  
Water Pump  
Pulley  
and 2-Gr.  
Crank Pulley  
used w/  
Alternator/Air



Edelbrock Long Water Pump

E

Fits all '69-'87 SBC  
and '73-'86 Light  
Duty Trucks  
6-15/16" surface to  
hub w/ 5/8" pilot.  
Can be used on  
any SBC engine  
that has room for  
LWP and  
accessories.

#11000402 Unpolished 215.95  
#11000402 Polished 290.95

SBC (w/ Long Water Pump) Engine & Accessories





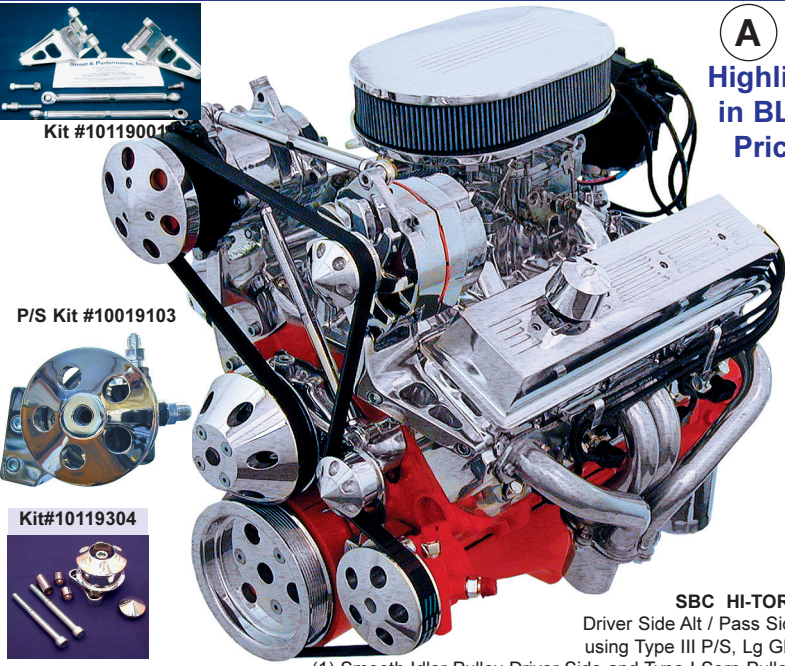

Kit #10119001

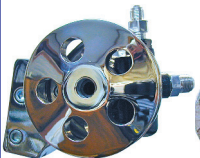

**A Kit Highlighted in BLUE Pricing**



P/S Kit #10019103



Kit #10119304

**SBC HI-TORQUE**  
 Driver Side Alt / Pass Side Air  
 using Type III P/S, Lg GM Alt,  
 (1) Smooth Idler Pulley Driver Side and Type I Serp Pulley Set



#10119003

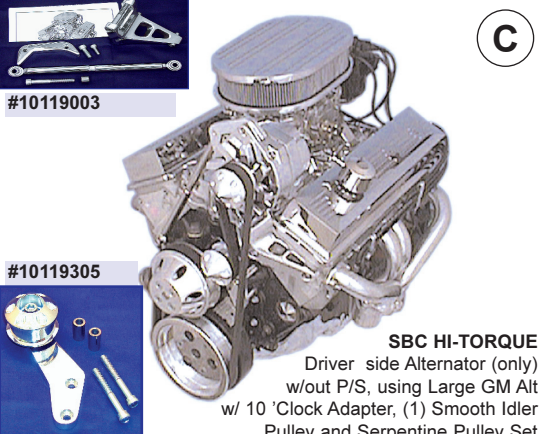

**C**



#10119305

**SBC HI-TORQUE**  
 Driver side Alternator (only)  
 w/out P/S, using Large GM Alt  
 w/ 10 'Clock Adapter, (1) Smooth Idler  
 Pulley and Serpentine Pulley Set



#10119003

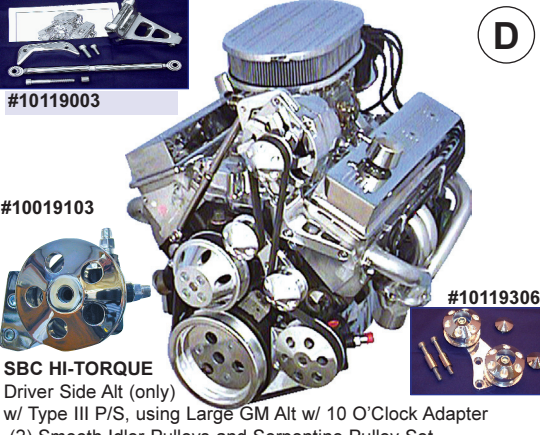

**D**



#10119306

**SBC HI-TORQUE**  
 Driver Side Alt (only)  
 w/ Type III P/S, using Large GM Alt w/ 10 O'Clock Adapter  
 (2) Smooth Idler Pulleys and Serpentine Pulley Set



#10119304



**B**

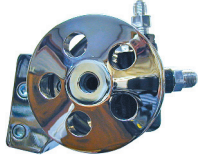

P/S Kit #10019103

**"NEW" ZZ-430 H.P.**

**SBC VORTEC HI-TORQUE**  
 Driver Side Alt / Pass Side Air  
 w/ Type III P/S, using Lg GM Alt,  
 (1) Smooth Idler Pulley & Serp Pulley Set



#12119001



#10119303

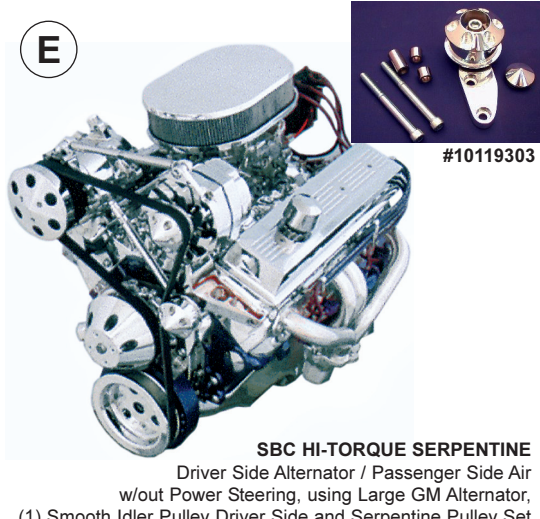

**E**



#10119303

**SBC HI-TORQUE SERPENTINE**  
 Driver Side Alternator / Passenger Side Air  
 w/out Power Steering, using Large GM Alternator,  
 (1) Smooth Idler Pulley Driver Side and Serpentine Pulley Set

Part #	HI-TORQUE BRACKET KITS - SERPENTINE (Inc.: Brackets, Adjusting Bars and Bolts)	Natural	Polish	Chrome
		10119001	Driver Side Alternator / Passenger Side Air Kit	280.95
12119001	Driver Side Alternator / Passenger Side Air Kit (Vortec)	280.95	302.95	322.95
10119003	Driver Side Alt (only) Kit w/10 O'Clock Adapter & Bar	167.95	177.95	199.95
12119003	Driver Side Alt (only) Kit (Vortec)w/10 O' Adapt & Bar	167.95	177.95	199.95
10109004	Pass Side Alt Kit w/2 O'Clock Adapter & Bar SB/Vortec	172.95	183.95	204.95
<b>HI-TORQUE BRACKETS (bolts included)</b>				
10112001	Driver Side Alternator Bracket	86.95	97.95	108.95
12112001	Driver Side Alternator Bracket (Vortec)	86.95	97.95	108.95
10112006	Passenger Side Air Bracket	86.95	97.95	108.95
12112006	Passenger Side Air Bracket (Vortec)	86.95	97.95	108.95
00000001	10 O'Clock Alternator Adapter	N/A	26.95	38.95
00000002	2 O'Clock Alternator Adapter	N/A	26.95	38.95
<b>HEIM END ADJUSTING BARS (bolts inc)</b>				
10109100	2 - S.S Bars w/ Heim End Alternator/Air Kit	N/A	107.95	N/A
10109101	S.S Bar w/ Heim End Alternator (only) to W/P	N/A	53.95	N/A
10109103	S.S Bar Passenger Air to W/P	N/A	53.95	N/A
10109102	S.S Top Bar w/ Heim End Alternator to Air	N/A	53.95	N/A
10119303	Driver Side Tall Idler Set w/ 1 Smooth Idler	N/A	129.95	151.95
10119304	Driver Side Small Idler Set w/ 1 Smooth Idler	N/A	118.95	140.95
10119305	Driver Side Large Idler Set w/ 1 Smooth Idler	N/A	129.95	151.95
10119306	Driver Side Idler Set w/ Dual Smooth Idlers	N/A	199.95	231.95
10019103	SB Type III P/S Serp uses Remote Reservoir	280.95	302.95	322.95
10019104	SB Type III P/S Serp w/ New Pump / Plastic Reservoir	376.95	398.95	430.95





**F**



**HI-TORQUE KIT #10119001**  
 Alternator & Air Bracket complete with Bolts, S.S. Adjusting Bars  
 w/ Heim Ends and Instruction Sheet.



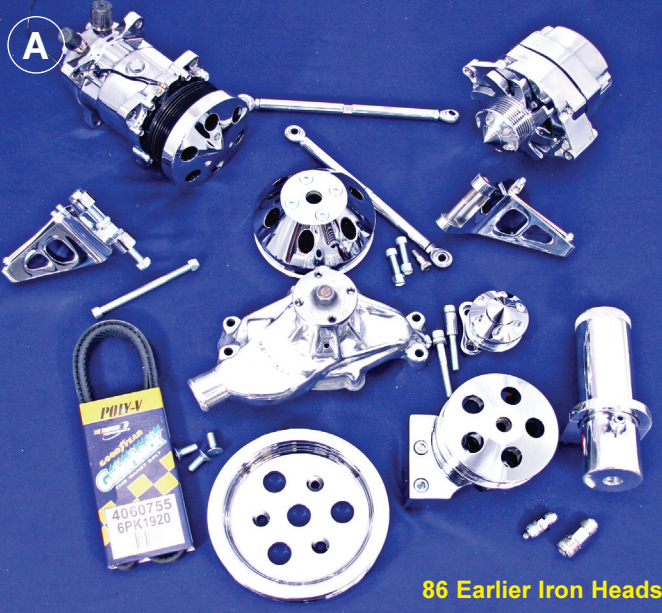

**86 Earlier Iron Heads**



**Complete Bracket Kits (as pictured)** includes, Water Pump, Pulley Set, Idler Kit, PS Kit, GM 1 Wire 90 Amp Alternator, 508 Sanden Compressor, Alum. Alt Fan, 508 Front Cover, all Mounting Bolts, Gaskets and Belt. *(Any item that you already have can be removed from the package and price reduced.)*

Part #		Polished	Chrome
	A. Alt, Air & PS Package 86 earlier	\$1929.95	\$2176.95
	B. Alt, Air & PS Package 87 up Vortec	\$1929.95	\$2176.95
	D. Alt & PS ONLY Package	\$1348.95	\$1542.95
	E. Alt, Air No PS Package -'86 Earlier	\$1469.95	\$1656.95
	F. Alt, Air No PS Package - '87 up Cast Iron / Vortec	\$1469.95	\$1656.95

Part#		Polished	Chrome
00000080	Alum Straight Up Water Neck	42.95	52.95
	3/8" fuel line rubber . . . . .	10.95	13.95
	3/8" Braided hose . . . . .	10.95	13.95
	5/8" Rubber heater hose . .	12.95	16.95
	5/8" Braided hose . . . . .	12.95	16.95
	3/4" Rubber heater hose . .	12.95	16.95
	1 1/4", Rad rubber hose . .	19.95	24.95
	1 1/2" Rad rubber hose . . .	19.95	24.95
	1 3/4" Rad rubber hose . . .	19.95	24.95
	2" Rad rubber hose . . . . .	20.95	25.95



**S&P Exclusive**  
O-Ring Gasket - Straight Up  
Water Neck Pat. Pending

**Hi-Torque Alt & PS ONLY**  
All driver side heads have the  
same bolt pattern.

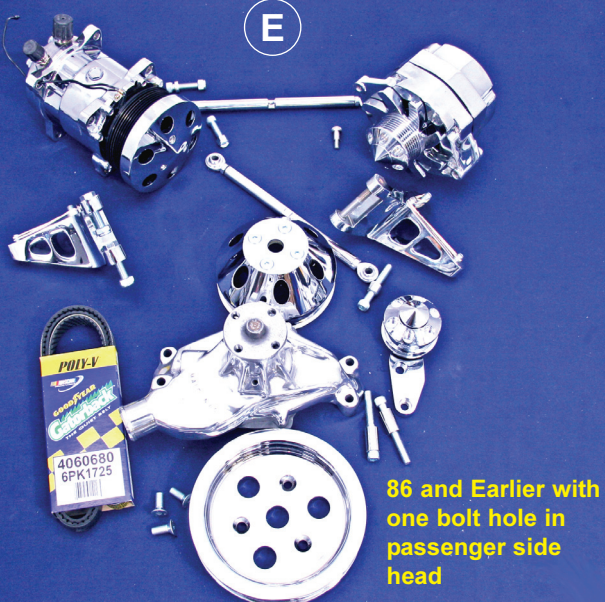

**86 and Earlier with one bolt hole in passenger side head**



**87 Up Vortec or GM Aluminum Heads**

**11**  
**SBC (Hi-Torque) Brackets - Serpentine**  
**11**



**(A)**

# 10009102

#10119001

**SBC TYPE II SERP SET**  
Driver Side Alt / Pass Side Air with Type II P/S, using Lg GM Alt, Serpentine Crank and V-Belt P/S

**TIMING CHAIN COVER**

'74 & Later #10000036

7" Pointer #1000041

8" Pointer #1000042

8" Pointer #1000039

7" Pointer #1000038

**(B)**

SS Bolt Kit #0000040

Part#	Timing Chain Covers & Accessories (Chrome Cover comes w/ Front Seal)	Polish	Chrome
10000036	Chrome GM '74 & Later Steel Timing Cover	-	72.95
10000037	Chrome GM '73 & Earlier Steel Timing Cover	-	72.95
10000038	S/B Aluminum 7" Timing Pointer	37.95	47.95
10000039	S/B Aluminum 8" Timing Pointer	37.95	47.95
00000040	SS S/B Timing Cover Bolt Kit	11.95	N/A
10000041	Chrome GM 7" Timing Pointer	-	18.95
10000042	Chrome GM 8" Timing Pointer	-	18.95
10000043	SB Timing Chain Cover Gasket	17.99	-

**S/B SERPENTINE PULLEYS (C)**

**S/B WATER PUMPS (D)**

#10000402

#10000403

**S/B COMPRESSORS (E)**

#00110508 R-12

#00110509 R-134

Part #	HI-TORQUE SERPENTINE PULLEY SETS	Natural	Polish	Chrome
	Includes: Pulleys and Bolts			
10119051	Serpentine Pulley Set (Crank, W/P, and Alt) Smooth Vette W/Pump Pulley w/ 3/4" Pilot	N/A	263.95	317.95
10119052	Serpentine Pulley Set (Crank, W/P, and Alt) Ribbed Vette W/Pump Pulley w/ 3/4" Pilot	N/A	263.95	317.95
10119053	Serpentine Pulley Set (Crank, W/P, and Alt) Smooth W/Pump Pulley w/ 5/8" Pilot	N/A	263.95	317.95
10119054	Serpentine Pulley Set (Crank, W/P, and Alt) Ribbed W/Pump Pulley w/ 5/8" Pilot	N/A	263.95	317.95
	<b>INDIVIDUAL SERPENTINE PULLEYS</b>			
10110093	1. SBC Serp Crank Pulley	N/A	108.95	135.95
00110030	2. SBC Serp Ribbed Alternator Pulley	N/A	48.95	59.95
00110085	3. SBC Serp Ribbed W/P Pulley 5/8" Pilot	N/A	108.95	135.95
10110086	4. SBC Serp Vet Sm W/P Pulley 3/4" Pilot	N/A	108.95	135.95
10110087	4a. SBC SerpVet Rib W/P Pulley 3/4" Pilot	N/A	108.95	135.95
10110088	5. Smooth W/P Pulley 5/8" Pilot	N/A	108.95	135.95
00000020	6. Alternator Pulley Button (N/C w/ Pulley)	N/A	8.95	11.95
00000007	7. Large Alum Alternator Fan	N/A	43.95	53.95
00000008	7a.Small Alum Alternator Fan	N/A	43.95	53.95
00000011	8. Type III 508 Compressor Front Cover	N/A	53.95	64.95
00000420	9. Long 1/2" Pipe to 5/8" Hose Bib	N/A	19.49	21.49
00000421	10. Long 1/2" Pipe to 3/4" Hose Bib	N/A	19.49	21.49
00000423	11. Short 1/2" Pipe to 5/8" Slip-on	N/A	17.49	20.49
00000422	11a.Short 1/2" Pipe to 3/4" Slip-on	N/A	17.49	20.49

Part #	HI-TORQUE SERPENTINE ACCESSORIES	Natural	Polish	Chrome
00000424	12. Short 1/2" Pipe to #8 A/N	-	17.49	20.49
00000425	13. Chrome 1/2" Pipe Plug	-	-	6.95
10000900	14. S/B S.S. Water Pump Bolt Kit	-	16.95	-
10000950	15. S/B Water Pump Gasket Kit	2.50	-	-
	<b>HI-TORQUE SERPENTINE ACCESSORIES</b>			
10000402	16. Alum Edelbrock SWP Standard Rotation	215.95	290.95	-
10000403	17. Alum Vette Rev. Rotation 3/4" Pilot W/P	151.95	204.95	-
10119055	Type II Serp Pulley Set (V-Grv Crank, W/P, & Alt)	-	280.95	334.95
10019103	Type III Power Steering Kit for Serpentine	280.95	302.95	322.95
10019104	SB Type III P/S Kit new Pump & Plastic Res	376.95	398.95	430.95
00000105	"New" Aluminum P/S Pump (Add)	135.95	189.95	275.95
00000030	Idler Pulley (Smooth)	-	81.95	92.95
00000029	Idler Pulley (Ribbed)	-	81.95	92.95
10119303	Idler Bracket w/ Pulley Alt/Air no P/S	-	129.95	151.95
10119204	Idler Bracket w/ Pulley Alt/Air with P/S	-	129.95	151.95
10119205	Idler Bracket w/ Pulley Alternator Only	-	129.95	151.95
10119203	DbI Idler Bracket Alt and P/S w/ (2 pulleys)	-	199.95	231.95
00110508	18. 508 A/C Compressor R-12 Serpentine	226.95	280.95	334.95
00110509	19. 508 A/C Compressor 134 Serpentine	226.95	280.95	334.95
00000011	20. 508 Type III Front Cover	-	53.95	65.95
00000012	21. Old Style Large 508 Type III Front Cover	-	65.95	75.95
00000013	22. 508 Type I Smooth Front Cover	-	53.95	65.95
00000014	23. 709 Type III Front Cover	-	59.95	70.95
00110510	24. Serpentine Clutch Assembly w/ Pulley	102.95	-	-
00000704	GM Alternator 1-Wire 90 amp	97.95	146.95	161.95

Sets Include: Crank, W/P Pulley and Alt Pulleys (Fan optional). Pulley sets come standard w/ 6 7/8" dia. crank and 6" dia. water pump.

Water Pump Pulleys	Water Pumps	Compressors
Pulley 3 is used when running w/out air, pulley 5 is used when running alt/air with or w/out power steering, and pulley 4 is used when using Vette water pump w/3/4" shaft, alt/air with or w/out power steering.	You can use your standard rotation water pump in reverse by using a smaller diameter water pump pulley to increase water flow. Vette pump is more desirable due to 3/4" shaft and larger bearing.	If you've purchased a new compressor w/ V-belt, and desire to convert to serpentine, we'll exchange your clutch at N/C (freight not included). #20 and #22 are used with most standard 508 Compressors.



See Web for More Details

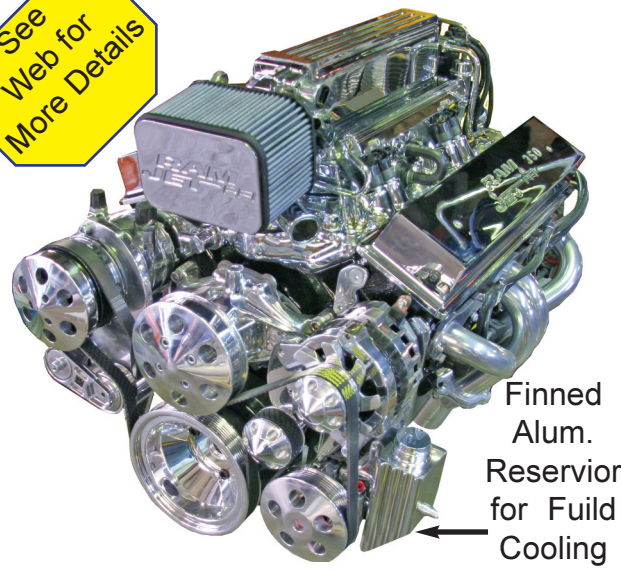

Finned Alum. Reservoir for Fluid Cooling

Tight Tuck with Self Contained PS Pump and Reservoir

Self Contained Alum. PS Pump Reservoir

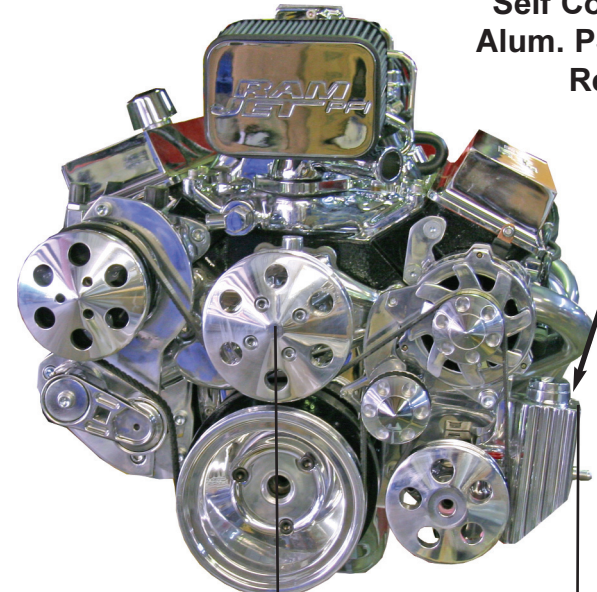

12"

See Your Rod Shop or Call for more Detail

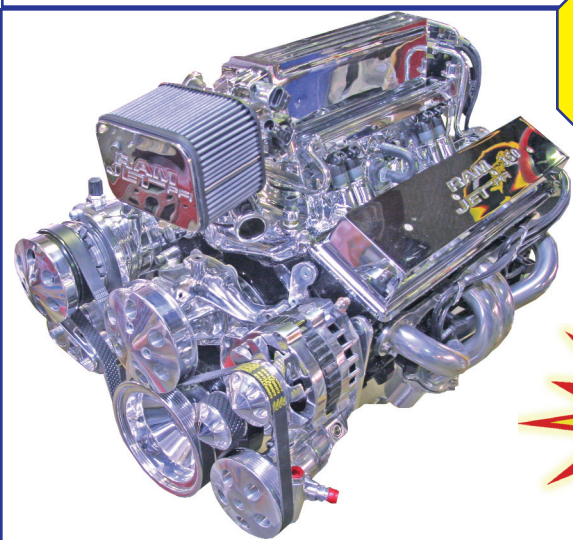

Tight Tuck With Remote PS Reservoir for Narrow Framed Chassis

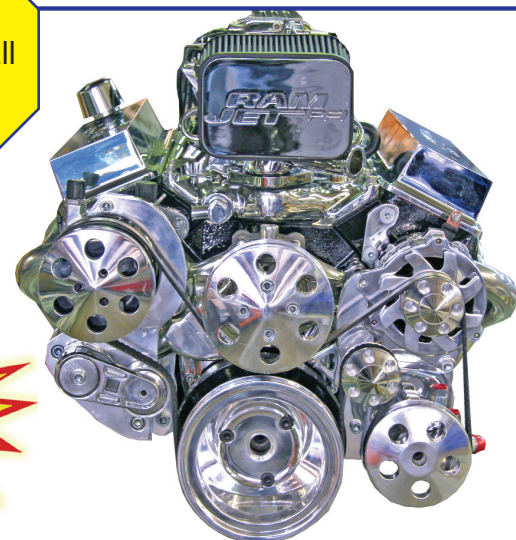

Optional 140 AMP ALT

Tight Tuck Brackets Will Clear Vette IROC/TA TPI Fuel Lines and Heater Hose Bibs

Available late 07

Only Kit Available in Chrome for easy Cleaning

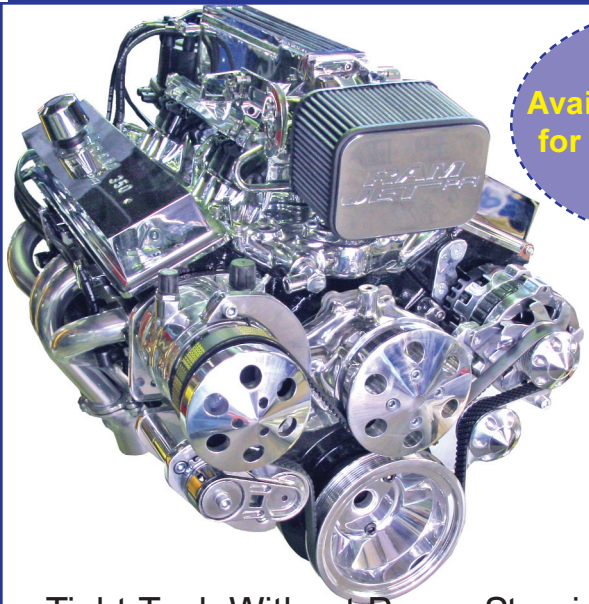

Tight Tuck Without Power Steering

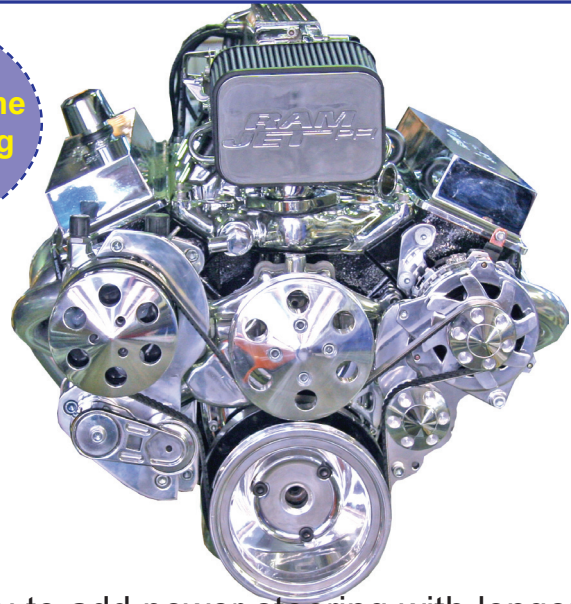

Easy to add power steering with longer belt and Bolt on Pump



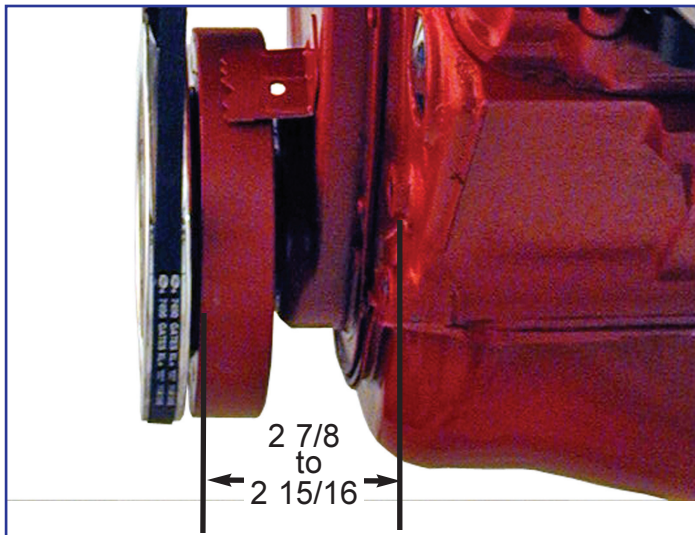

Small block short and long water pump engines, balancer should measure 2 7/8" to 2 15/16" from machined surface of block to the front of the balancer.



**\*\*\*INFORMATION\*\*\***  
**SBC Water Pump Information**

Measure your W/Pump height using a ruler and a straight edge.

**Standard Rotation**  
 SBC Short Water Pump 5-5/8" x 5/8"  
 SBC Long Water Pump 6-15/16" x 5/8"  
 SBC Vette SWP 5-13/16" x 3/4"

**Reverse Rotation**  
 SBC Short Water Pump 5-5/8" x 5/8"  
 SBC Long Water Pump 6-15/16" x 5/8"  
 SBC Vette SWP 5/8" x 5/8"

**Heim Ends - Aluminum**

# 99990300 Left	11.95
# 00000000 Right	11.95

**Heim Ends - Polished SS**

# 00000000 Left	19.95
# 00000000 Right	19.95

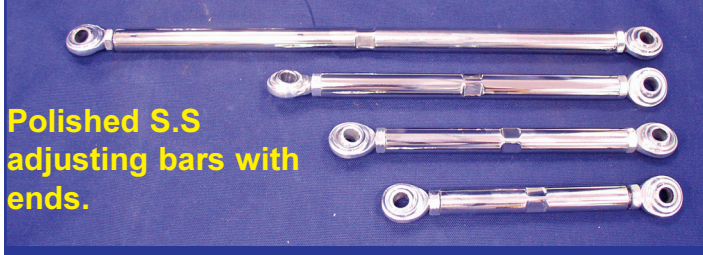

Need length of bar or center of heim to center of heim. 2 7/8" to 22" in 1/2" increments available.



**Custom Line Clamps**  
 3/16" -1/4"-5/16"-3/8"  
 7/16"- 1/2"-5/8"  
 Sold in package of six  
 3/16" to 3/8" \$16.95  
 7/16" to 5/8" \$21.95  
 Chrome Optional

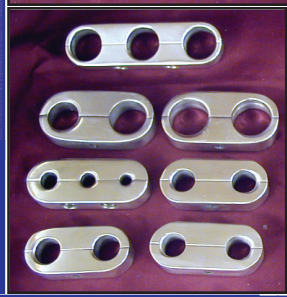

**Custom Hose Separators**  
 Available in single, double or triple configuration for rubber or braided hose. Many hole size configurations are available for your vehicle application. Finishes are available in polished or chrome and come with stainless steel bolts.

**Option:**  
 Separators can be purchased with a longer bolt and lock nut for mounting to inner fender or firewall.



Part#		Polished	Chrome
00000080	Alum Straight Up Water Neck	42.95	52.95
	3/8" fuel line rubber. . . . .	10.95	13.95
	3/8" Braided hose . . . . .	10.95	13.95
	5/8" Rubber heater hose ..	12.95	16.95
	5/8" Braided hose . . . . .	12.95	16.95
	3/4" Rubber heater hose ..	12.95	16.95
	1 1/4", Rad rubber hose ..	19.95	24.95
	1 1/2" Rad rubber hose ...	19.95	24.95
	1 3/4" Rad rubber hose ...	19.95	24.95
	2" Rad rubber hose . . . . .	20.95	25.95

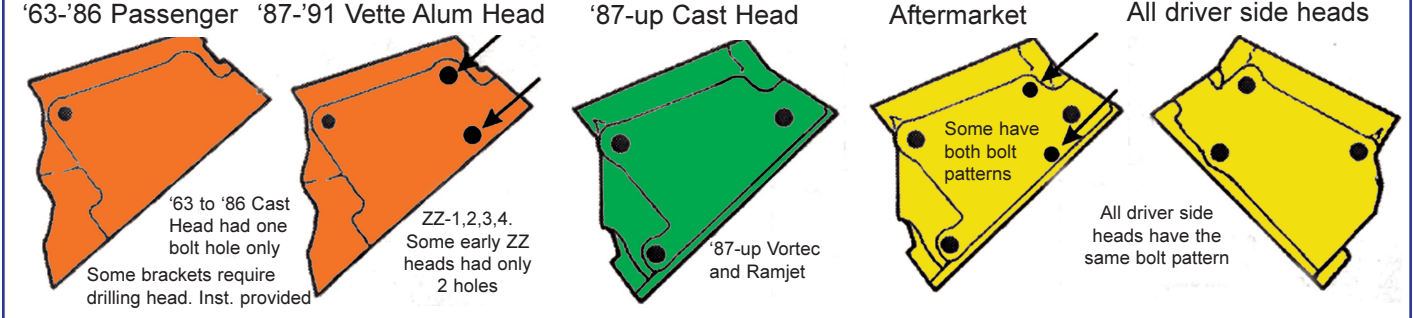



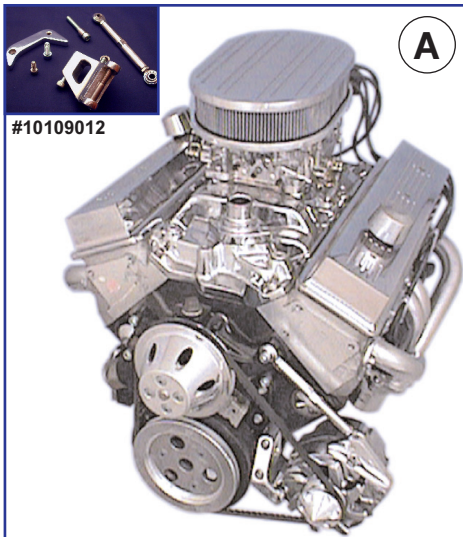

#10109012

(A)

**SBC V-BELT LOW DRIVER ALTERNATOR**

Low Driver Side Alternator (Only)  
w/out Power Steering, using Large GM Alternator w/ 10 O'Clock Adapter, Bar Kit & V-Belt Single Gr. Pulley Set

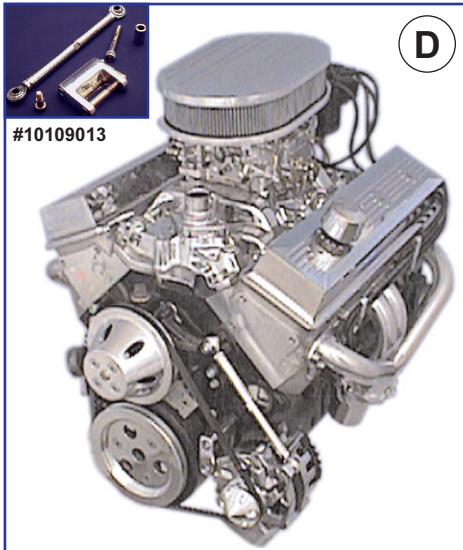

#10109013

(D)

**SBC V-BELT LOW TYPE II DRIVER SIDE ALT**

Low Driver Side Alt (Only)  
w/out Power Steering, using Small 10 O'Clock Alternator and V-Belt Single Groove Pulley Set

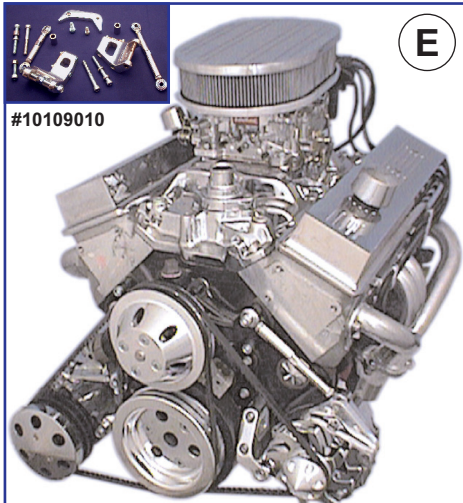

#10109010

(E)

**SBC LOW ALT/AIR**

Low Driver Side Alternator / Low Passenger Side Air  
w/out Power Steering, using Large GM Alternator w/ 10 O'Clock Adapter and V-Belt Dbl. Groove Pulley Set

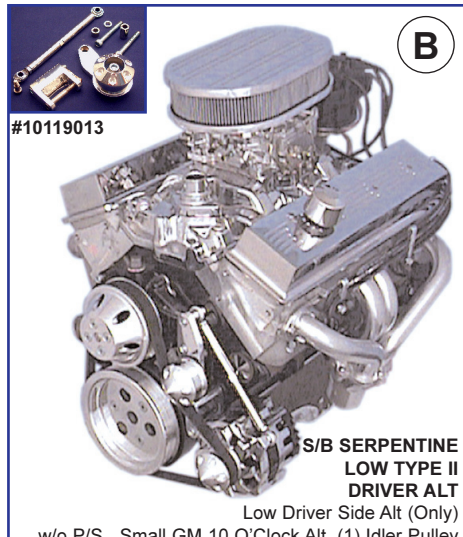

#10119013

(B)

**S/B SERPENTINE  
LOW TYPE II  
DRIVER ALT**  
Low Driver Side Alt (Only)  
w/o P/S, Small GM 10 O'Clock Alt, (1) Idler Pulley  
and Serpentine Pulley Set

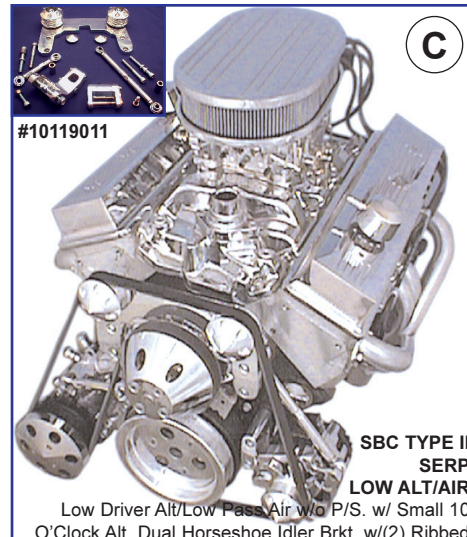

#10119011

(C)

**SBC TYPE II  
SERP  
LOW ALT/AIR**  
Low Driver Alt/Low Pass Air w/o P/S. w/ Small 10  
O'Clock Alt, Dual Horseshoe Idler Brkt. w/(2) Ribbed  
Idler Pulley, Bar Kit, and Serpentine Pulley Set

**Low Mount Brackets for Short Water Pump SBC**

Low mount alternator and air looks great but, will not clear in most chassis due to the front cross member or steering conflict.

Part #	LOW SHORT W/PUMP BRACKET KIT	Natural	Polished	Chrome
	Includes: Brackets, Bars and Bolts			
	NOTE: Type I Kit uses 10 O'Clock Adapter			
	Type II Kit uses Small 10 O'Clock Alternator			
10109010	Type I Low Alt Driver Low Air Pass Kit (V-belt)	199.95	221.95	253.95
10119010	Type I Low Alt Driver Low Air Pass Kit ( Includes Serp Idler)	N/A	458.95	554.95
10109011	Type II Low Alt Driver & Low Air Pass Kit (V-Belt)	199.95	221.95	253.95
10119011	Type II Low Alt Driver & Low Air Pass Kit ( Includes Serp Idler)	N/A	458.95	554.95
10109012	Type I Low 10 O' Clock Alt Driver Side Bracket Kit (V-Belt)	104.95	114.95	131.95
10119012	Type I Low 10 O' Clock Alt Driver Side Bracket Kit (( Includes Serp Idler)	222.95	232.95	271.95
10109013	Type II Low Alt Driver Side Bracket Kit (V-Belt)	104.95	114.95	131.95
10119013	Type II Low Alt Driver Side Bracket Kit (( Includes Serp Idler)	222.95	232.95	259.95
10109014	Pass Alt Low Bracket Kit w/ Bar (V-Belt)	101.95	111.95	128.95
	<b>LOW SHORT WATER PUMP ALTERNATOR AND AIR BRACKETS</b>			
10002008	Type I Low Alternator (only) Driver Side Bracket	51.95	59.95	75.95
10002009	Type II Low Alternator (only) Driver Side Bracket	51.95	59.95	75.95
10002011	Low Alternator (only) Passenger Side Bracket	51.95	59.95	75.95
10002010	Low Air Passenger Side Bracket	51.95	56.95	75.95
00000001	10 O'Clock Alternator Adapter Bracket for Driver Side	-	26.95	38.95
00000002	2 O'Clock Alternator Adapter Bracket for Passenger Side	-	26.95	38.95
	<b>SHORT W/PUMP LOW ADJUSTER BAR</b>			
10109106	S.S Low Type I Alt Driver Side Bar w/ Heim End (V-Belt)	-	53.95	-
10109107	S.S Low Type I Alt Driver Side Bar w/ Heim End (Serpentine)	-	53.95	-
10109108	S.S Low Type II Alt Driver Side Bar w/ Heim End (V-Belt)	-	53.95	-
10109109	S.S Low Type II Alt Driver Side Bar w/ Heim End (Serpentine)	-	53.95	-
10109110	S.S Low Alt Pass Side Bar w/ Heim End (V-Belt)	-	53.95	-
10109111	S.S Low Alt Pass Side Bar w/ Heim End (Serpentine)	-	53.95	-
10109112	S.S Low Pass Air Bar w/ Heim End (V-Belt or Serpentine)	-	53.95	-
00000000	***Polished SS Heim Ends (Add Per Bar)	-	12.95	-
	<b>SHORT W/PUMP LOW ACCESSORIES</b>			
10109050	SB 1-Groove Pulley Set (Crank, W/P, and Alt)	-	203.95	262.95
10109051	SB 2-Groove Pulley Set (Crank, W/P, and Alt)	-	209.95	268.95
10119051	SB Type I Serpentine Pulley Set (Crank, W/P, and Alt)	-	263.95	317.95
10119206	Low D/S Bracket & Idler Pulley (Smooth)	-	129.95	151.95
10119207	Low P/S Bracket & Idler Pulley (Smooth)	-	129.95	151.95
10109211	Horseshoe Idler for Low Alt and Air w/(2) Ribbed Idler Pulleys	-	236.95	302.95

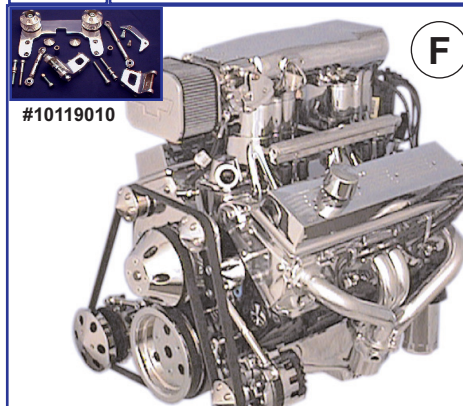

#10119010

(F)

**SBC LOW ALT/AIR**

Low Driver Side Alternator / Low Passenger Side Air  
w/out Power Steering, using Small GM 10 O'Clock  
Alternator and Serpentine Pulley Set

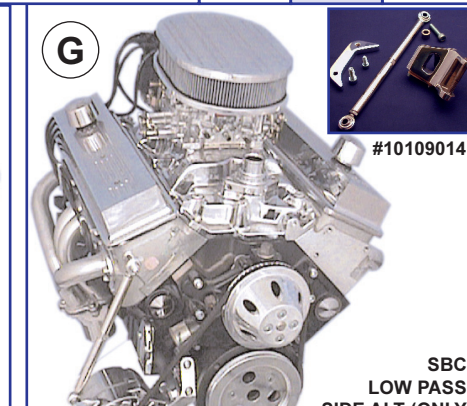

#10109014

(G)

**SBC  
LOW PASS  
SIDE ALT (ONLY)**

Low Pass Side  
Alt (Only) w/out P/S.  
Lg Alt w/ 2 O'Clock Adapter and V-Belt Groove  
Pulley Set

15 SBC (Low w/ Short Water Pump) Engine & Accessories 15



Same Bracket Kit, Pulley Set and Idlers as "A"

**B**

This Kit works well with B&M or Weiand Street Blower

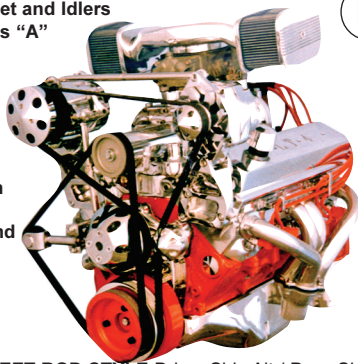

**SB STREET ROD STYLE** Driver Side Alt / Pass Side Air Street Blower w/out P/S, using Lg GM Alt, Smooth Idler D/Size and Serpentine Pulley Set

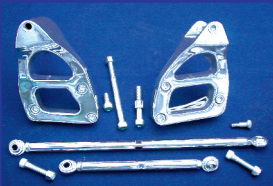

#10519001

#12519001

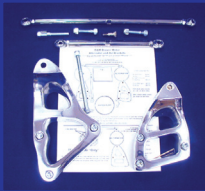

#10519051

NOTE: We offer these Brackets in LWP "Special Order Only" See Page 26

**A**

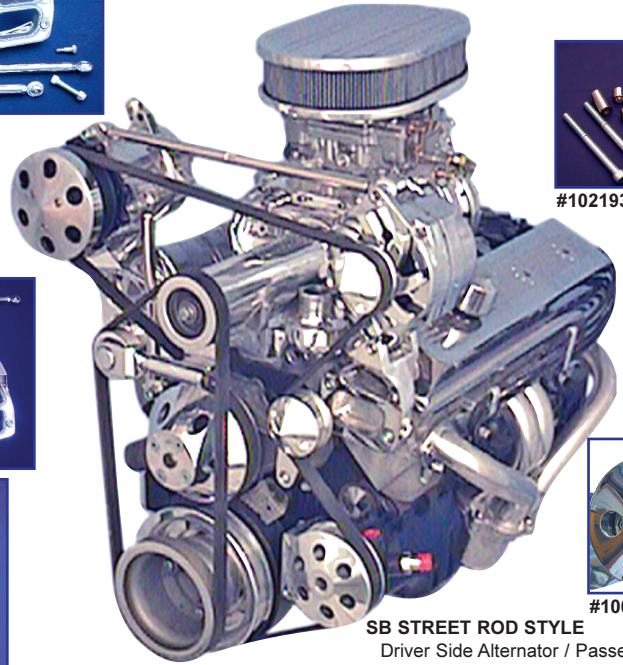

#10219303



#10019103

**SB STREET ROD STYLE**

Driver Side Alternator / Passenger Side Air Street Blower using Type III Power Steering, Large GM Alternator, Short Water Pump, (1) Smooth Idler Pulley Driver Side and Serpentine Pulley Set

NOTE: WHEN USING THE "SMALL" WEIAND BLOWER FOR A STREET ROD APPLICATION, YOU MUST USE THE SERPENTINE BELT DRIVE SYSTEM!

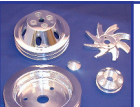

#10509051

#10009102



**C**

This set-up works best in vehicles with close side room, like Street Rod, Jeep or small engine compartment vehicles. To Run Type II P/S, requires long water pump blower snout.

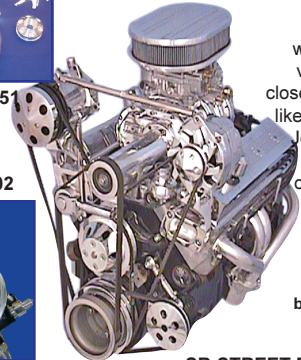

**SB STREET ROD STYLE**

Driver Side Alternator / Passenger Side Air St/Rod Brkt Kit w/ Street Blower using Type II Power Steering, V-Belt Pulley Set and 3-Gr Crank



#10009101

#10509051

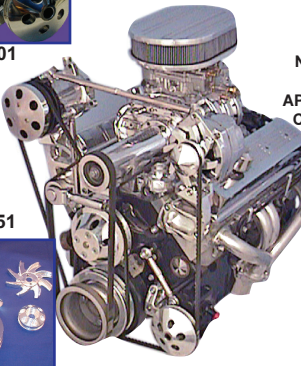
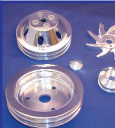

**D**

NOTE: MOST VEHICLE APPLICATIONS CANNOT RUN THE TYPE I POWER STEERING DUE TO CLEARANCE OF MANY STEERING & CROSS MEMBERS!

**SB STREET ROD STYLE** Driver Side Alt / Pass Side Air Street Blower using Type I P/S, Lg GM Alt and V-Belt Double Groove Pulley Set

Part #	SWP BLOWER ALT/AIR BRACKET AND BAR KIT	Natural	Polished	Chrome
10509001	Alt Driver Side & Air Pass Side Kit V-Belt	285.95	317.95	350.95
12509001	Alt Driver Side & Air Pass Side Kit V-Belt 87-up Cast Iron Head	296.95	329.95	371.95
10519001	Alt Driver Side & Air Pass Side Serpentine Kit	285.95	317.95	350.95
12519001	Alt Driver Side & Air Pass Side Kit Serp 87-up Cast Iron Head	296.95	329.95	371.95
10509003	Driver Side Alt Only Kit (Includes Adj. Bar and Snout Bracket)	205.95	216.95	253.95
10509004	Pass Side Alt Only Kit (Includes Adj. Bar and Snout Bracket)	211.95	213.95	259.95
<b>STREET BLOWER ALT AND AIR BRACKETS</b>				
10502001	SB Alt (only) Driver Side Bracket (V-Belt or Serpentine)	92.95	102.95	124.95
10102002	SB Alt (only) Passenger Side Bracket (V-Belt or Serpentine)	92.95	102.95	124.95
10502006	SB Air (only) Passenger Side Bracket (V-Belt)	92.95	102.95	124.95
10512006	SB Air (only) Passenger Side Bracket (Serpentine)	92.95	102.95	124.95
10500050	B&M Type I Alt (only) Snout Bracket	N/A	59.95	75.95
10500051	B&M Type II Alt (only) Snout Bracket	N/A	70.95	86.95
<b>HEIM END ADJUSTER BAR &amp; ACCESSORIES</b>				
10109116	2 - S.S Heim End Bar Alt to Air	N/A	107.95	N/A
10109117	S.S Heim End Bar Air to W/P	N/A	53.95	N/A
10109118	S.S Heim End Bar B&M Snout Driver Side- Type I & Type II	N/A	53.95	N/A
10109119	S.S Heim End Bar B&M Snout Pass Side - Type I & Type II	N/A	53.95	N/A
10500063	B&M Style Driver Side Offset Water Neck	70.95	81.95	97.95



**BLOWER OFFSET WATER NECK**

The B&M Type Blower Offset Water Neck is used w/ B&M Street Blowers for applications which are close to the radiator.  
#10500063 - Neck  
#00000066 - Gasket  
W/Neck comes w/ Gasket & Bolts

Snout Brackets & Bars

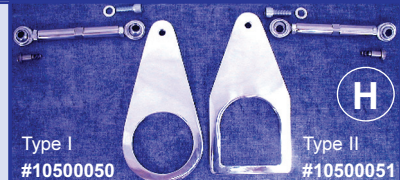

Type I  
#10500050

Type II  
#10500051



#10509051

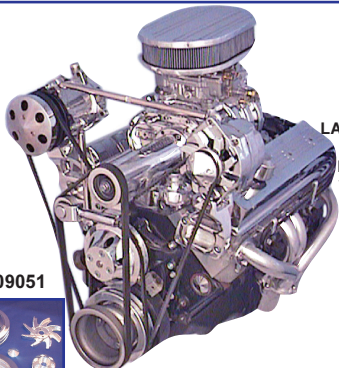

**SB STREET ROD STYLE**

Driver Side Alt / Pass Side Air w/out P/S, using Lg GM Alt, and V-Belt Double Groove Pulley Set

**E**

NOTE: ON SOME LATE MODEL B&M BLOWERS, YOU MUST NOTCH THE BLOWER NECK TO RUN V-BELT.



#10509050



**STREET BLOWER STYLE**

Pass Side Alt (Only) w/o P/S, Lg Alt, SWP w/Blower Snout Bracket Kit for adjustment, and V-Belt Pulley Set

**F**

NOTE: S&P Brackets can be used with long or short Blower Snouts

Note: B&M small blower w/ V-belt on driver side on later models, idler base on blower neck has to be notched to clear V-belts

**G**

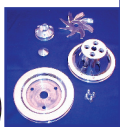

#10509050



#10509003

**SHORT W/PUMP**

Driver Side Alt (Only) SWP w/ LWP Snout, lets you run 3-Groove Crank for Type II P/S



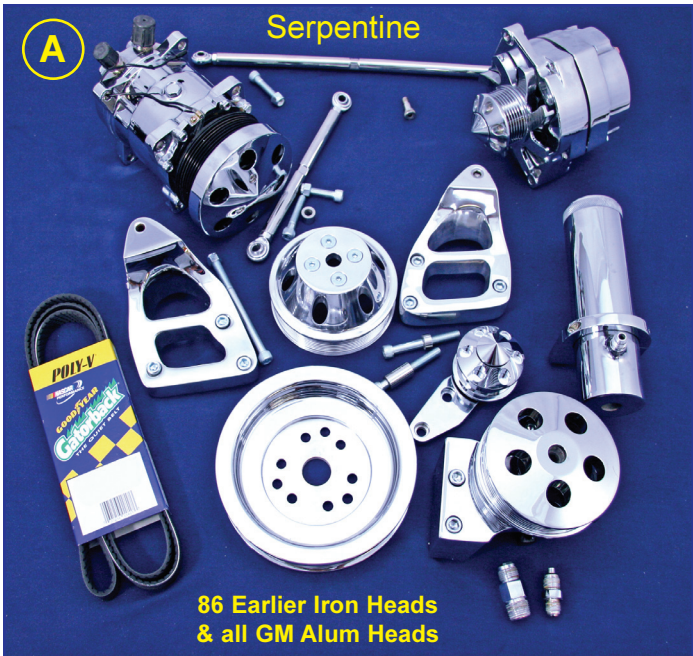

**86 Earlier Iron Heads & all GM Alum Heads**

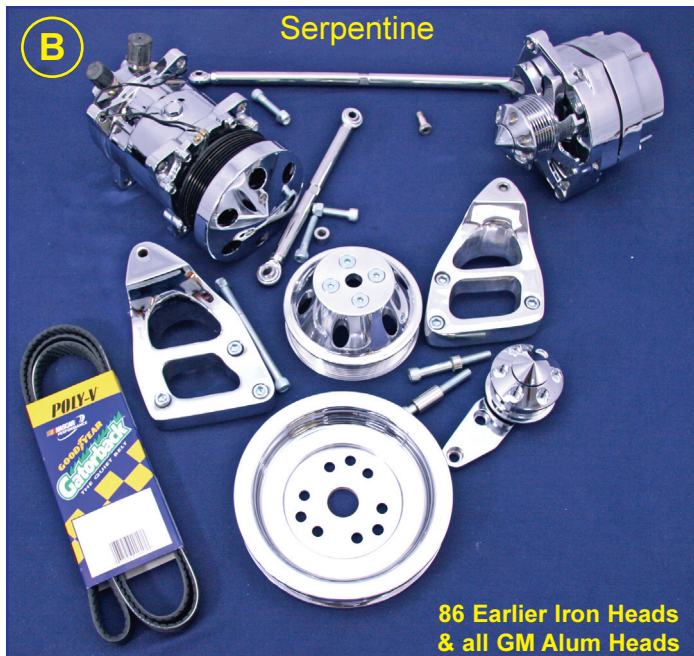

**86 Earlier Iron Heads & all GM Alum Heads**

**SWP BLOWER ALT/AIR V-BELT BRACKET AND BAR KIT**  
 Complete Bracket Kits (as pictured) includes, Pulley Set, Idler Kit, PS Kit, GM 1 Wire 90 Amp Alternator, 508 Sanden Compressor, Alum. Alt Fan, 508 Front Cover, all Mounting Bolts, and Belts. Optional Water Pump Available **(Any item that you already have can be removed from the package and price reduced.)**

Part #	BLOWER Alt & Air With Power Steering	Polished	Chrome
A.	Blower Serpentine Alt & Air Kit with Type III P.S Pump (Kit fits 86 Earlier Iron Heads) & all GM Alum Heads. ....	1773.95	1989.95
D.	Blower V-Belt Alt & Air Kit with with Type I (Kit fits 86 Earlier Iron Heads) & all GM Alum Heads. ....	1567.95	1804.95
<b>BLOWER Alt &amp; Air Without Power Steering</b>			
B.	Blower Serpentine Alt & Air Kit (Kit fits 86 Earlier Iron Heads) & all GM Alum Heads. ....	1303.95	1500.95
C.	Blower V-Belt Alt & Air Kit (Kit fits 87 later Iron Heads) & some aftermarket Alum Heads. ....	1097.95	1274.95
<b>BLOWER Alt ONLY Driver Side</b>			
E.	Blower Alt Only. ....	642.95	759.95
<b>BLOWER ACCESSORIES</b>			
10609050	1-Gr. V-Belt Blower Pulley Set (Crank, W/P, and Alt) . . . . .	N/A	216.95 270.95
10609051	2-Gr. V-Belt Blower Pulley Set (2-Groove Crank, W/P, and Alt) . . . . .	N/A	221.95 275.95
10609052	2-Gr. V-Belt Blower Pulley Set (3-Groove Crank, W/P, and Alt) . . . . .	N/A	238.95 293.95
10619051	Type I Serp Pulley Set (Crank, W/P Smooth, Alt, & No Hub) . . . . .	N/A	285.95 339.95
10219303	Blower Driver Side Single Smooth Idler w/ Bracket . . . . .	N/A	129.95 151.95
10000402	Alum. Edelbrock SWP Standard Rotation 5/8" Pilot . . . . .	215.95	290.95 N/A
10110403	Alum. GM Vette SWP Reverse Rotaion 3/4" Pilot . . . . .	151.95	204.95 N/A



**ALT ONLY**  
 MUST KNOW WHAT TYPE OF BLOWER NECK CALL FOR MORE INFORMATION.

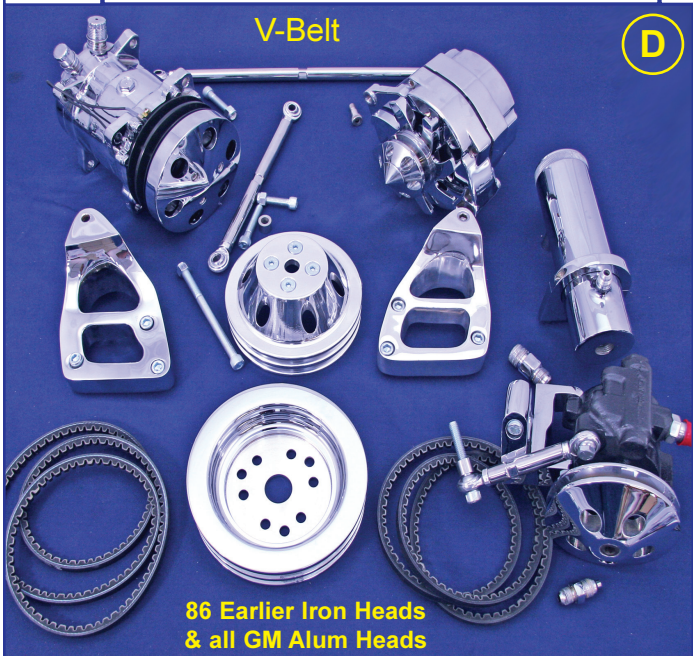

**86 Earlier Iron Heads & all GM Alum Heads**

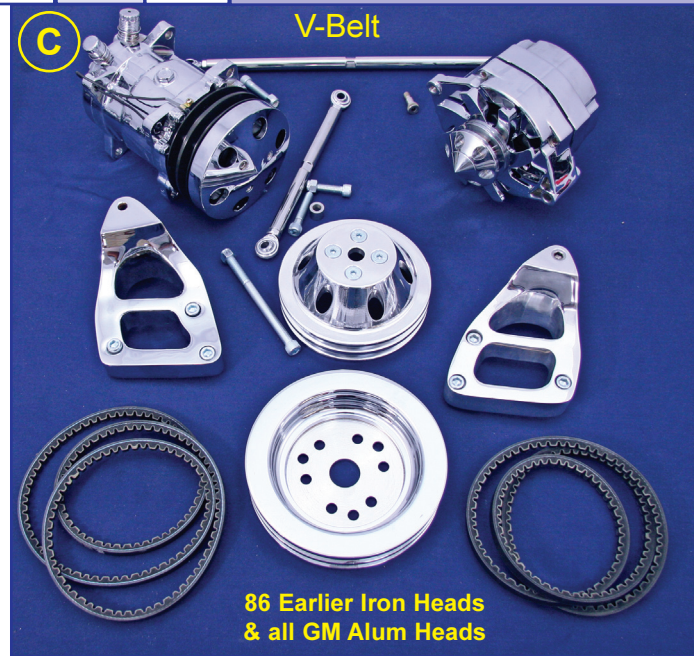

**86 Earlier Iron Heads & all GM Alum Heads**

**17 SBC Blower/Street Rod Style Bracket - V-Belt/Serpentine 17**



**A** Kit Highlighted in BLUE Pricing

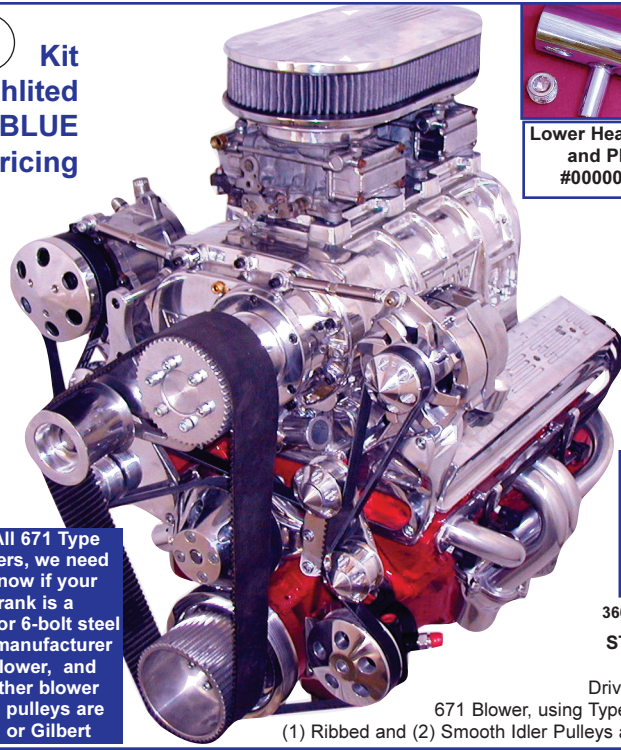

On All 671 Type Blowers, we need to know if your crank is a 3-bolt or 6-bolt steel hub, manufacturer of blower, and whether blower drive pulleys are MM or Gilbert

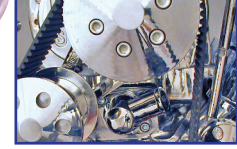

**STREET ROD BRACKETS W/ 671 BLOWER**

Driver Side Alt / Pass Side Air 671 Blower, using Type III P/S, Lg GM Alt, SWP, (1) Ribbed and (2) Smooth Idler Pulleys and Serpentine Pulley Set

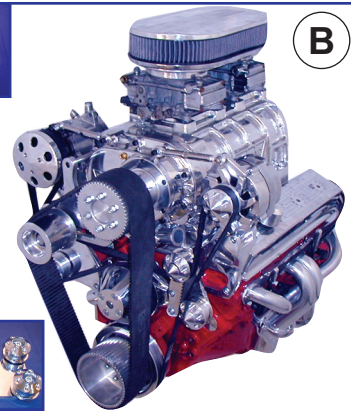

#10619307

**STREET ROD BRACKETS W/ 671 BLOWER**  
Driver Side Alt / Pass Side Air w/out P/S, using Lg GM Alt, SWP, (4) Idler Pulleys and Serp Pulley Set

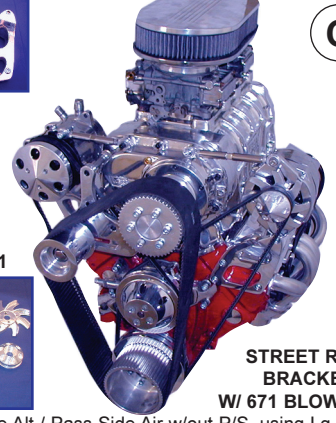

#10509051

**STREET ROD BRACKETS W/ 671 BLOWER**  
Driver Side Alt / Pass Side Air w/out P/S, using Lg GM Alt, SWP and V-Belt Pulley Set



#10009101

**STREET ROD BRACKETS W/ 671 BLOWER**  
Driver Side Alt / Pass Side Air using Type I P/S, with Lg GM Alt, SWP and V-Belt Pulley Set

NOTE: Type I P/S doesn't clear in most Applications

Part #	SMALL BLOCK 671/871 TYPE BLOWER	Natural	Polished	Chrome
10609001	Alt/Air Blower Bracket Kit V-Belt Short Bars	302.95	323.95	366.95
10619001	Alt/Air Blower Bracket Kit Serpentine Short Bars	302.95	323.95	366.95
10609002	Alt/Air Blower Bracket Kit V-Belt Long Bars	307.95	344.95	377.95
10619002	Alt/Air Blower Bracket Kit Serpentine Long Bars	307.95	344.95	377.95
10609003	Driver Side Alt (Only) Bracket Kit - Short Bar (V-Belt or Serp) .	154.95	166.95	186.95
<b>BRACKET &amp; BLOWER ACCESSORIES</b>				
10602001	671/871 Alt (Only) Bracket	100.95	111.95	132.95
10602006	671/871 Air Bracket V-Belt	100.95	111.95	132.95
10612006	671/871 Air Bracket Serpentine	100.95	111.95	132.95
10609050	1-Gr. V-Belt Blower Pulley Set (Crank, W/P, and Alt)	N/A	216.95	270.95
10609051	2-Gr. V-Belt Blower Pulley Set (2-Groove Crank, W/P, and Alt)	N/A	221.95	275.95
10609052	2-Gr. V-Belt Blower Pulley Set (3-Groove Crank, W/P, and Alt)	N/A	238.95	293.95
10619051	Type I Serp Pulley Set (Crank, W/P Smooth, Alt, & No Hub)	N/A	285.95	339.95
10619053	Type I Serp Pulley Set (Crank, W/P Smooth, Alt, & Hub 3-Bolt)	N/A	370.95	424.95
10619054	Type I Serp Pulley Set (Crank, W/P Smooth, Alt, & Hub 6-Bolt)	N/A	370.95	424.95
10619052	Type I Serp Pulley Set (Crank, W/P Ribbed, Alt, & No Hub)	N/A	285.95	339.95
00110085	1) Serpentine Water Pump Pulley - Ribbed 5/8" Pilot	N/A	108.95	135.95
00100086	2) 1-Gr. V-Belt Water Pump Pulley 6" Dia.	N/A	92.95	115.95
00100085	3) 2-Gr. V-Belt Water Pump Pulley 6" Dia.	N/A	92.95	115.95
00100088	4) 2-Gr. V-Belt Water Pump Pulley 5 3/4" Dia.	N/A	102.95	122.95
00110086	5) Serpentine Water Pump Pulley - Vette 3/4" Pilot	N/A	108.95	135.95
00110088	6) Serpentine Water Pump Pulley - Smooth 5/8" Pilot	N/A	108.95	135.95
10500092	7) 1-Gr. Blower V-Belt Crank Pulley	N/A	92.95	115.95
10600052	8) 3-Bolt S/B Crank Blower Drive Hub Adapter	N/A	84.95	N/A
10600053	9) 6-Bolt S/B Crank Blower Drive Hub Adapter	N/A	84.95	N/A
10500093	10) 2-Gr. V-Belt Crank Pulley	N/A	94.95	127.95
10500094	3-Gr. V-Belt Crank Pulley (not pictured)	N/A	115.95	137.95
10510093	11) Serpentine Crank Pulley	N/A	124.95	151.95
00000007	12) Large Aluminum Alternator Fan	N/A	43.95	53.95
00110030	13) Serpentine Alternator Pulley	N/A	48.95	59.95
00100030	14) V-Belt Alternator Pulley	N/A	35.95	46.95
10619307	Alt/Air Idler Bracket Kit w/ 4 Pulleys and 2 Brackets	N/A	398.95	473.95
00000073	360/10 Degree Swivel Water Neck	70.95	81.95	92.95
10109120	S.S Heim End Bar Alt to Blower (671 - 871)	N/A	59.95	N/A
10109121	S.S Heim End Bar Air to Blower (671 - 871)	N/A	59.95	N/A
10109122	S.S Heim End Long Bar Alt to Air (471 - B&M Mega Blower)	N/A	63.95	N/A
10019103	Type III Power Steering Serp. Uses Remote Reservoir	280.95	302.95	322.95

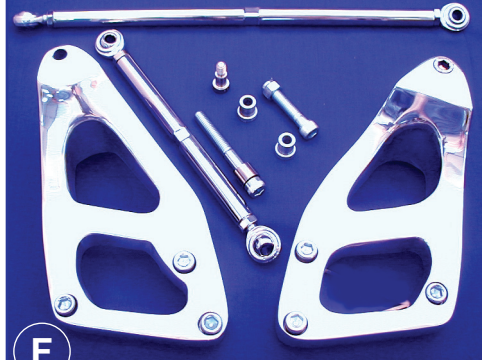
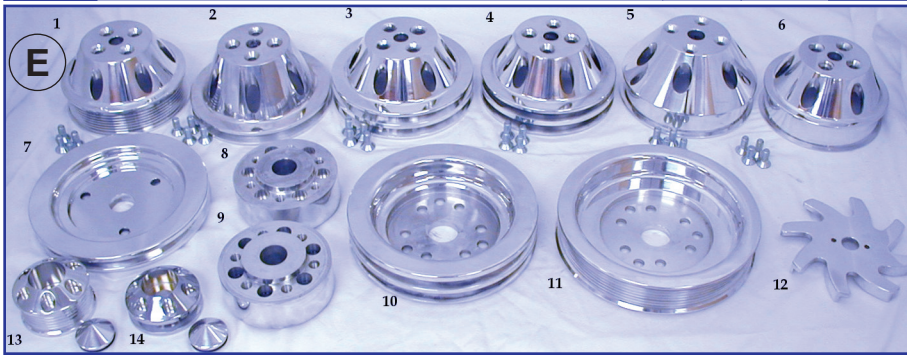

**F**  
**671/871 MEGA BLOWER STYLE LONG BAR KIT**  
This kit is used when doing 471 and B&M Type Mega Blowers, where top bar extends across the snout.  
V-Belt #10609002 - Serpentine #10619002



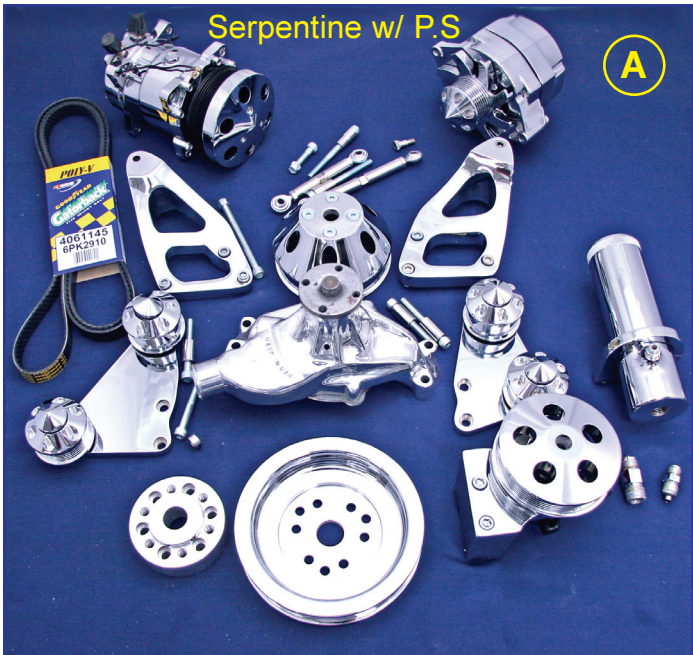

Serpentine w/ P.S

(A)



Serpentine No P.S

(B)

**SWP BLOWER ALT/AIR V-BELT BRACKET AND BAR KIT**  
 Complete Bracket Kits (as pictured) includes, Water Pump, Pulley Set, Idler Kit, PS Kit, GM 1 Wire 90 Amp Alternator, 508 Sanden Compressor, Alum. Alt Fan, 508 Front Cover, all Mounting Bolts, and Belts. **(Any item that you already have can be removed from the package and price reduced.)**

Part #	BLOWER Alt & Air With Power Steering	
	Polished	Chrome
A. Blower Serpentine Alt & Air Kit with Type III P.S Pump (Kit fits 86 Earlier Iron Heads) & all GM Alum Heads (Includes Hub Adaptor) . . . . .	2336.95	2659.95
D. Blower V-Belt Alt & Air Kit with Type I PS (Kit fits 87 later Iron Heads) & some aftermarket Aluminum Heads. (Includes Hub Adaptor) . . . . .	1658.95	1905.95
<b>BLOWER Alt &amp; Air Without Power Steering</b>		
B. Blower Serpentine Alt & Air Kit (Kit fits 86 Earlier Iron Heads) & all GM Alum Heads (Includes Hub Adaptor) . . . . .	1866.95	2128.95
C. Blower V-Belt Alt & Air Kit (Kit fits 87 later Iron Heads) & some aftermarket Alum Heads (Includes Hub Adaptor) . . . . .	1187.95	1374.95

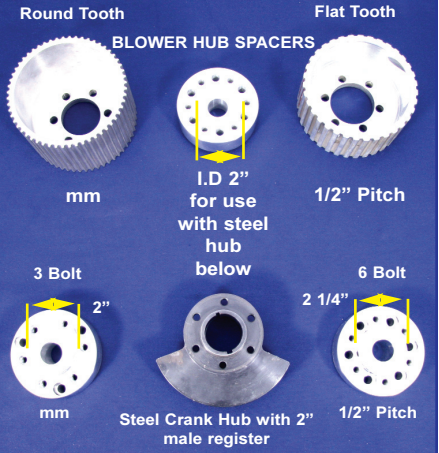

**360 / 10 Water Neck**  
**\$79.95 Polished**  
**\$89.95 Chrome**

**BLOWER HUB SPACERS**  
 It helps us to know what brand of blower you have. Weiland, B&M, Hampton, Holley, BDS and Mooneyham all have slightly different drives. We also need to know Crank bolt configuration, i.e. 3 bolt or 6 bolt balancer, fluid dampner or 6 bolt steel hub with male register.

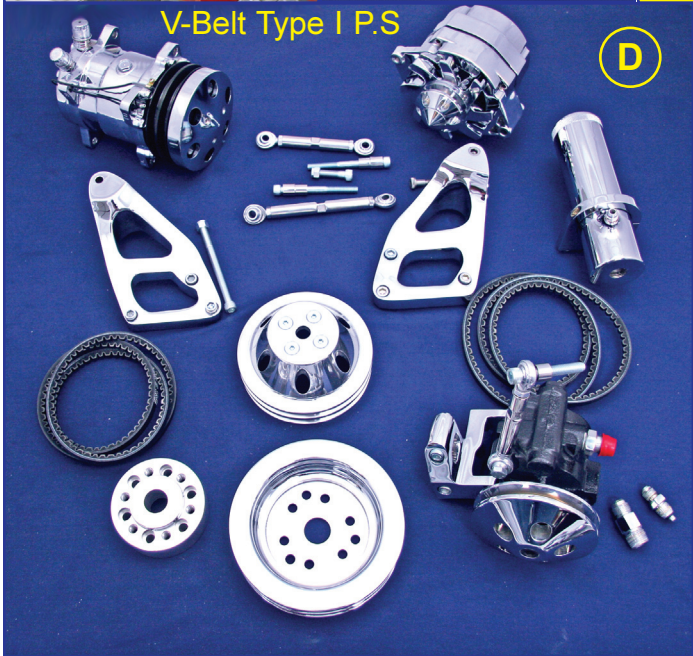

V-Belt Type I P.S

(D)



V-Belt No P.S

(C)

**10 SBC Blower/Street Rod Style Bracket - V-Belt/Serpentine**



**B**

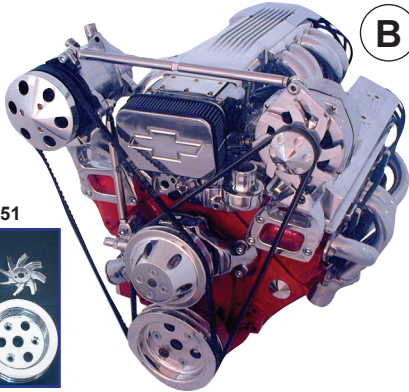

#10109051



**S/B GM TPI UNIT STREET ROD STYLE**  
Driver Side Alt / Pass Side Air w/out P/S, using Lg GM Alt Short Brackets, Alt and 2-Groove V-Belt Pulley Set

**C**

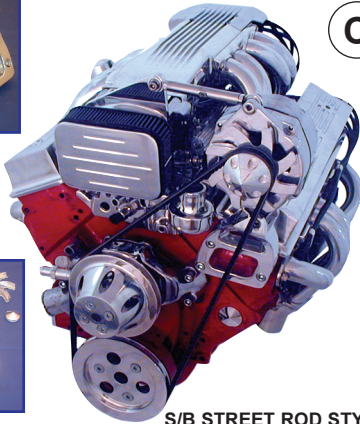

#10209003



#10109050



**S/B STREET ROD STYLE**  
Driver Side Alt (Only) w/out P/S, using Lg GM Alt, SWP and 1-Groove V-Belt Pulley Set

**D**

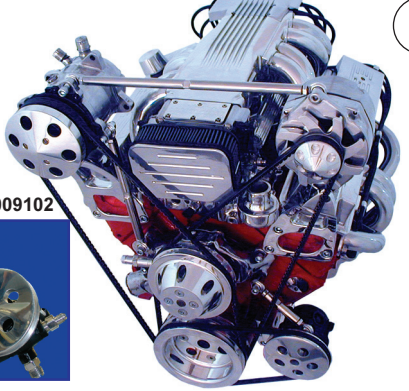

#10009102



**S/B STREET ROD STYLE TALL**  
Driver Side Alt / Pass Side Air w/Type II P/S, & Lg GM Alt, SWP, Tall Brackets & 2-Gr. V-Belt Pulley Set w/ 3-Gr. Crank

**E**

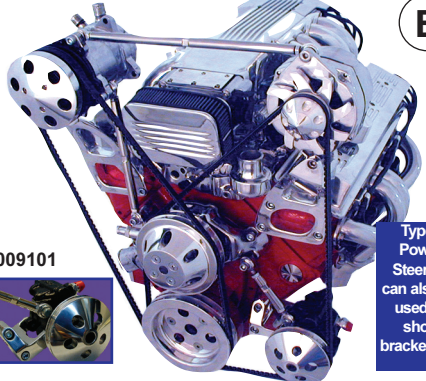

#10009101



Type I Power Steering can also be used w/ short bracket kits.

**S/B TPI STREET ROD STYLE TALL**  
Driver Side Alt/Pass Side Air w/Type II P/S, w/Lg GM Alt, SWP, Tall Brackets & 2-Gr. V-Belt Pulley Set w/ 3-Gr. Crank

NOTE: WHEN USING THE STREET ROD STYLE ALTERNATOR/AIR V-BELT APPLICATION, YOU MUST USE THE 1 3/4" TPI AIR FILTER! ENGINES OVER 275 h.p. NEED AT LEAST A 2 1/2" FILTER

**A**

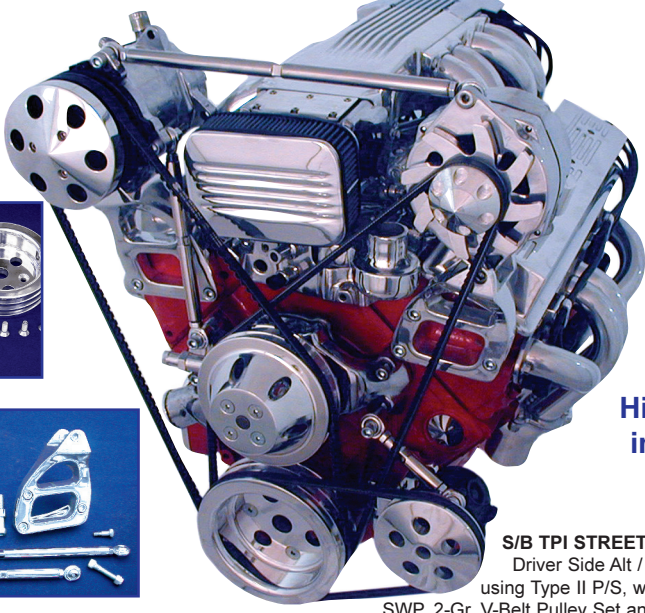

#10009102



#10109052



#10209001

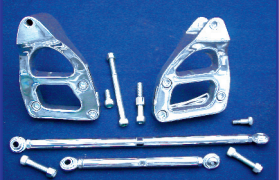

**Kit Highlighted in BLUE Pricing**

**S/B TPI STREET ROD STYLE**  
Driver Side Alt / Pass Side Air using Type II P/S, with Lg GM Alt, SWP, 2-Gr. V-Belt Pulley Set and 3-Gr. Crank

Street & Performance manufactures both short and tall alternator/air brackets. Short brackets look better because they show off the injection unit. Street & Performance short valve covers, both early or late, will clear most roller rocker arms. The short alternator/air brackets are a must on '33 - '39 Fords; tall brackets hit the top tank of the radiator. Tall brackets are for use with all tall valve covers. Short Brackets must be used on '57 Chevy w/ battery box in stock location.

Part #	STREET ROD STYLE BRACKET KITS Includes: Bracket, Adjusting Bars and Bolts	Natural	Polished	Chrome
10209001	Short Alt Driver Side & Air Passenger Side V-Belt Kit ...	285.95	317.95	350.95
12209001	Short Alt D/Side & P/Air V-Belt (87-up Cast Iron Head) ...	296.95	329.95	371.95
10209031	Tall Alt Driver Side & Air Passenger Side V-Belt Kit ...	296.95	329.95	371.95
10209003	Short Alt (only) Driver Side V-Belt Kit ...	189.95	199.95	243.95
10209032	Tall Alt (only) Driver Side V-Belt Kit ...	210.95	221.95	263.95
11209001	Short Alt/Air LWP V-Belt Bracket Kit ...	371.95	404.95	436.95
11209031	Tall Alt/Air LWP V-Belt Bracket Kit ...	382.95	414.95	458.95
<b>STREET ROD STYLE ALT AND AIR BRACKETS</b>				
10202001	Short Alternator (only) Driver Side Bracket ...	92.95	102.95	124.95
10202006	Short Air (only) Passenger Side Bracket ...	92.95	102.95	124.95
12202006	Short Air (only) P/Side Bracket 87-up Cast Iron Head ...	102.95	113.95	135.95
10202033	Tall Air (only) Passenger Side Bracket ...	105.95	115.95	137.95
10202034	Tall Alternator (only) Bracket ...	105.95	115.95	137.95
<b>STAINLESS ADJUSTER BARS</b>				
10109123	TPI Alt (only) 4" Heim End Bar ...	N/A	53.95	N/A
10109124	TPI Alt to Air 13 1/2" Heim End Bar ...	N/A	53.95	N/A
10109117	TPI Air to W/P 7" (Short Bracket) Heim End Bar ...	N/A	53.95	N/A
10109126	TPI Air to W/P 8" (Tall Bracket) Heim End Bar ...	N/A	53.95	N/A
10109127	TPI 2 - Heim End Bars (Short Bracket) Alt/Air to W/P ...	N/A	107.95	N/A
10109125	TPI 2 - Heim End Bars (Tall Bracket) Alt/Air to W/P ...	N/A	107.95	N/A
	***Polished SS Heim Ends (Add Per Bar) ...	N/A	12.95	N/A
<b>V-BELT ACCESSORIES</b>				
10110403	Aluminum Vette Short Water Pump - 3/4" Pilot ...	151.95	204.95	N/A
10000402	Aluminum Edelbrock Short Water Pump - 5/8" Pilot ...	215.95	290.95	N/A
10000401	(Chrome) Steel GM Factory Short Water Pump ...	N/A	N/A	137.95
10109050	SB 1-Gr. V-Belt Pulley Set (Crank, W/P, and Alt) ...	N/A	203.95	262.95
10109051	SB 2 Gr. V-Belt Pulley Set (Crank, W/P, Alt) ...	N/A	209.95	268.95
10109052	SB 2 Gr. V-Belt Set (3-Groove Crank, W/P, & Alt) ...	N/A	230.95	294.95
10009102	SB Type II Power Steering Kit for V-Belt ...	290.95	302.95	322.95
00000105	"New" Alum Type II, Type III, or Type IV P/S Pump	135.95	189.95	270.95

**F**

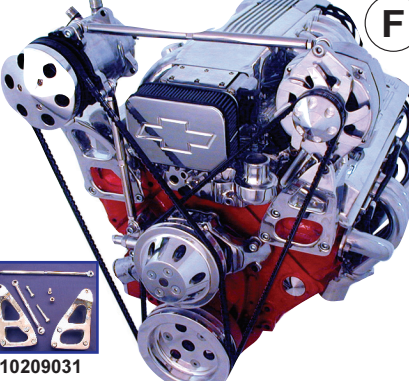

#10209031



**S/B STREET ROD STYLE TALL**  
Driver Side Alt/Pass Air w/o P/S, Large Alt, SWP, Tall Brackets and 2-Gr. V-Belt Pulley Set

**G**

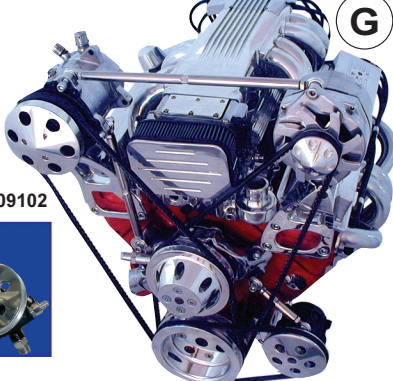

#10009102



**S/B TPI STREET ROD STYLE TALL**  
Driver Alt/ Pass Air, Type II P/S, w/ Large Alt, SWP, Tall Brackets and 2-Gr. PulleySet w/ 3-Gr. Crank



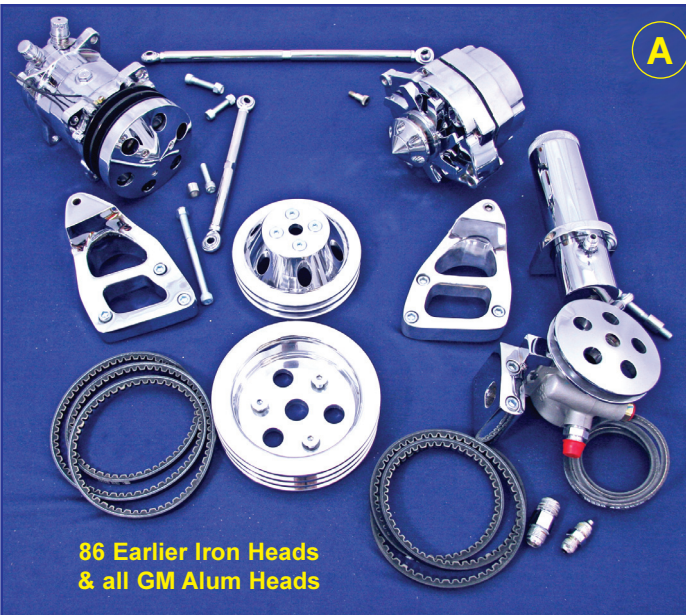

**86 Earlier Iron Heads  
& all GM Alum Heads**

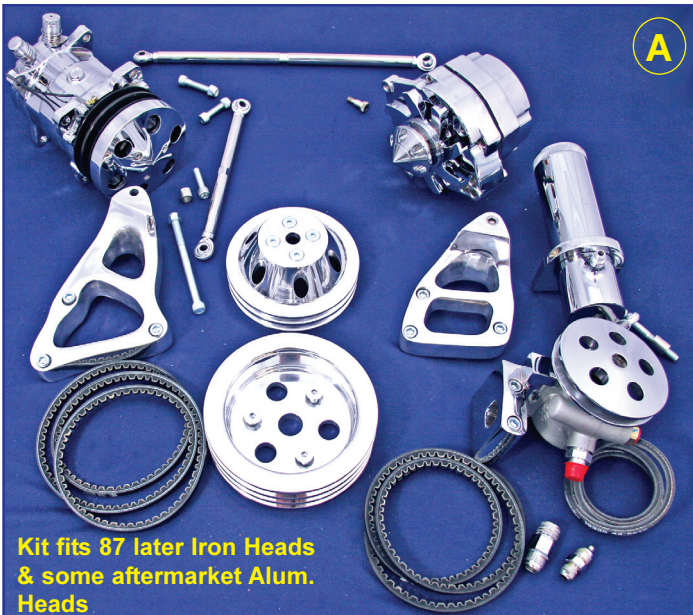

**Kit fits 87 later Iron Heads  
& some aftermarket Alum.  
Heads**

**SWP TPI ALT/AIR V-BELT BRACKET AND BAR KIT**  
 Complete Bracket Kits (as pictured) includes, Pulley Set, Idler Kit, PS Kit, GM 1 Wire 90 Amp Alternator, 508 Sanden Compressor, Alum. Alt Fan, 508 Front Cover, all Mounting Bolts, and V-Belts. **(Any item that you already have can be removed from the package and price reduced.)**

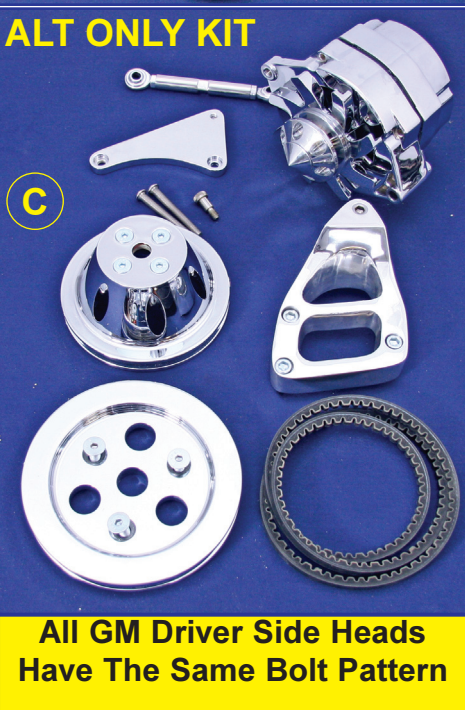

**All GM Driver Side Heads  
Have The Same Bolt Pattern**

Part #	TPI Alt & Air With Power Steering	Polished	Chrome
A.	TPI Alt & Air Kit with Type II P.S Pump (Kit fits 86 Earlier Iron Heads) & all GM Alum Heads. ....	1599.95	1839.95
A.	TPI Alt & Air Kit with Type II P.S Pump (Kit fits 87 later Iron Heads) & some aftermarket Aluminum Heads. ....	1610.95	1849.95
<b>TPI Alt &amp; Air Without Power Steering</b>			
B.	TPI Alt & Air Kit (Kit fits 86 Earlier Iron Heads) & all GM Alum Heads. ....	1097.95	1276.95
B.	TPI Alt & Air Kit (Kit fits 87 later Iron Heads) & some aftermarket Alum Heads. ....	1107.95	1287.95
<b>TPI Alt ONLY Driver Side</b>			
C.	TPI Alt Only .....	619.95	743.95

Part#	TPI Accessories	Polished	Chrome
A.	SBC Fuel Pump Block Off	38.95	48.95
B.	1/2" Pipe Long 3/4" Hose Bib (for water pump)	19.49	21.49
C.	1/2" Pipe Long 5/8" Hose Bib (for water pump)	19.49	21.49
D.	1/2" Pipe Short 5/8" Hose Bib	17.49	20.49
E.	1/2" Pipe 90 5/8" Hose Bib	17.49	20.49

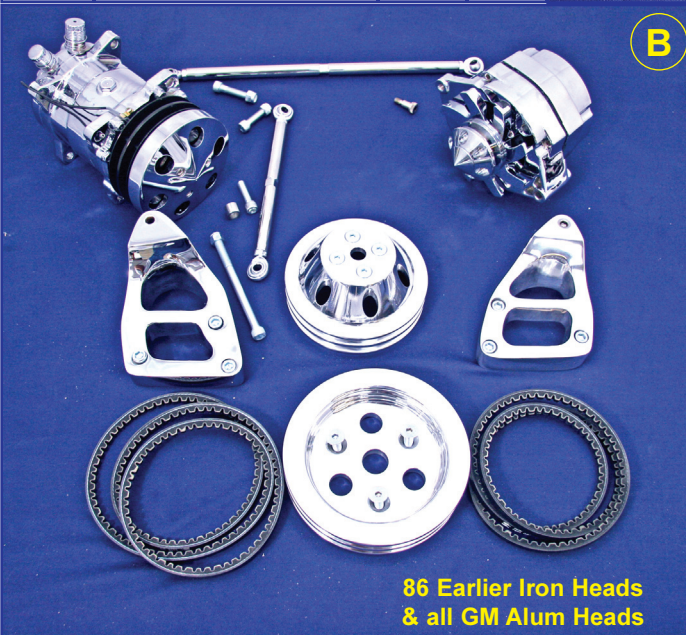
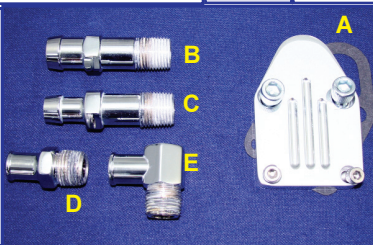

**86 Earlier Iron Heads  
& all GM Alum Heads**

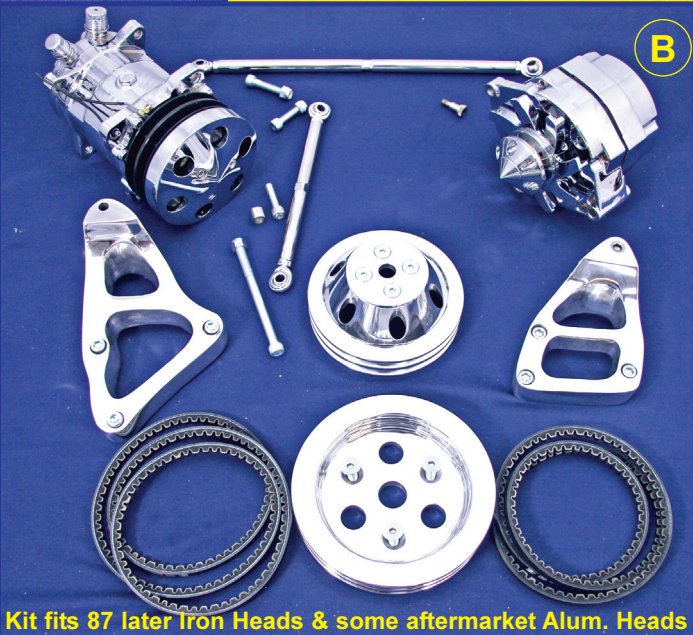

**Kit fits 87 later Iron Heads & some aftermarket Alum. Heads**





#10009102



#10109052

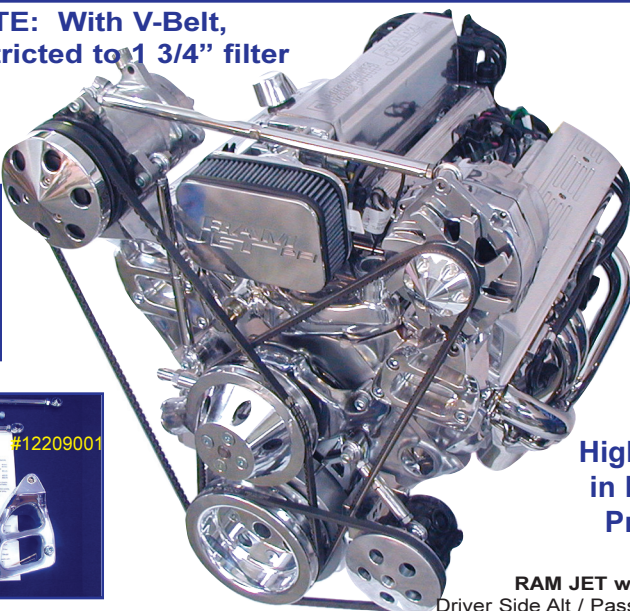
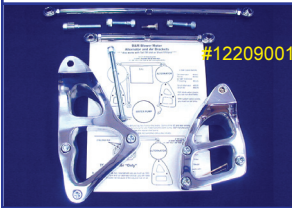

**NOTE: With V-Belt, restricted to 1 3/4" filter**

**A**

**Kit Highlighted in BLUE Pricing**

**RAM JET w/ V-BELT**

Driver Side Alt / Pass Side Air using Type II P/S, with Lg GM Alt, 3-Gr. Crank & 2-Gr. W/P V-Belt Pulley Set. This application runs a 1 3/4" filter w/ V-Belt Street Rod Brackets. Serpentine runs larger 2 1/2" up filter.

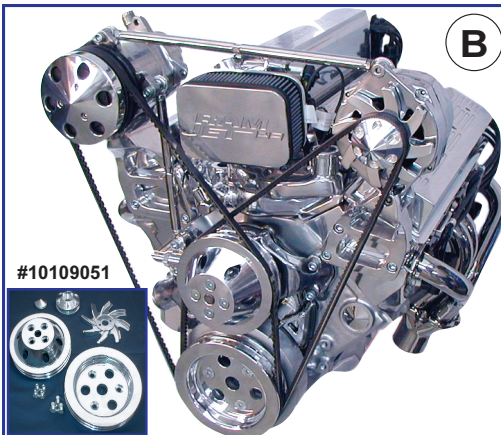

#10109051



**B**

**STREET ROD BRACKET KIT**  
Driver Side Alt / Pass Side Air w/out P/S, Large Alt, 2-Gr. Crank and V-Belt Pulley Set  
NOTE: Needs S&P Ram Jet Offset Water Neck

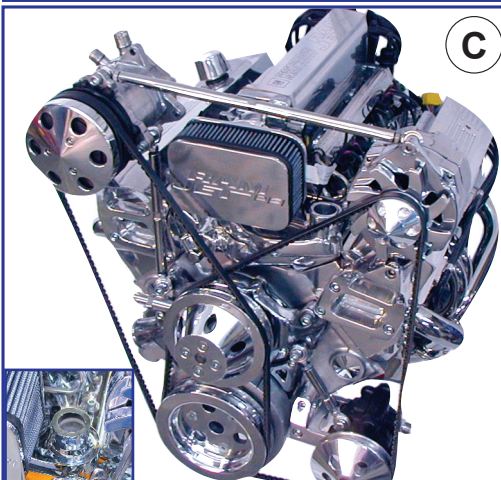

**C**

**STREET ROD BRACKET KIT**  
#10000067 Driver Side Alt/Pass Side Air w/ Type I P/S, 2-Gr. Crank & 2-Gr. W/Pump Pulley Set.  
NOTE: Needs S&P Ram Jet Offset Water Neck

Part #	STREET ROD STYLE BRACKET KITS Includes: Bracket, Adjusting Bars and Bolts	Natural	Polished	Chrome
10209001	Short Alt Driver Side & Air Passenger Side V-Belt Kit	285.95	317.95	350.95
12209001	Short Alt D/Side & P/Side Air V-Belt 87-up Cast Iron Head	296.95	329.95	371.95
10209031	Tall Alt Driver Side & Air Passenger Side V-Belt Kit	296.95	329.95	371.95
10209003	Short Alt (only) Driver Side V-Belt Kit	189.95	199.95	243.95
10209032	Tall Alt (only) Driver Side V-Belt Kit	210.95	221.95	263.95
11209001	Short Alt/Air LWP V-Belt Bracket Kit 87-up Cast Iron Head	371.95	404.95	436.95
11209031	Tall Alt/Air LWP V-Belt Bracket Kit 87-up Cast Iron Head	382.95	414.95	458.95
<b>STREET ROD STYLE ALT AND AIR BRACKETS</b>				
10202001	Short Alternator (only) Driver Side Bracket V-Belt	92.95	102.95	124.95
10202006	Short Air (only) Passenger Side V-Belt Bracket	92.95	102.95	124.95
12202006	Short Air (only) P/Side V-Belt Bracket 87-up Cast Iron Head	102.95	113.95	135.95
10202033	Tall Air (only) Passenger Side Bracket	105.95	115.95	137.95
10202034	Tall Alternator (only) Bracket	105.95	115.95	137.95
00000001	10 O'Clock Alternator Adapter Bracket for Driver Side	N/A	26.95	38.95
00000002	10 O'Clock Alternator Adapter Bracket for Passenger Side	N/A	26.95	38.95
10009102	SB Type II Power Steering Kit for V-Belt	290.95	302.95	322.95
10109052	SB 2 Gr. V-Belt Set (3-Groove Crank, W/P, & Alt)	N/A	236.95	293.95

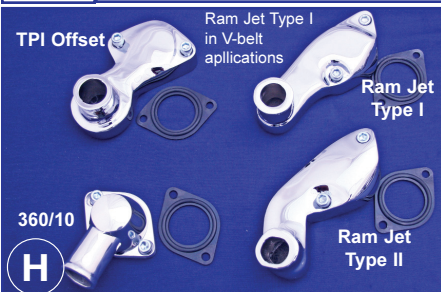

**TPI OFFSET & 360/10 DEGREE WATER NECK**  
S&P Water necks are designed for specific applications, off-set water neck work great in street rod applications fitting close to the radiator. The 360/10 Degree Water neck, is designed for the 40's and later model vehicles.

	Natural	Polished	Chromed
00000073 360°/10°	70.95	79.95	89.95
10000071 TPI Offset	70.95	81.95	92.95
10000067 Ram Jet Type I	70.95	81.95	92.95
10000068 Ram Jet Type II	70.95	81.95	92.95

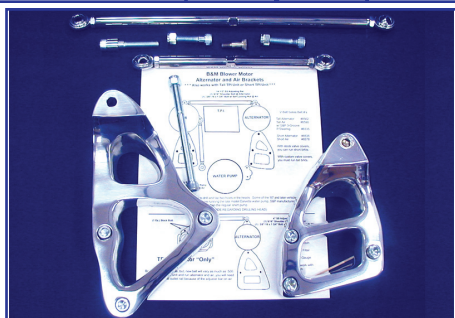

**Ram Jet Street Rod Alt & Air Bracket Kit**  
With this New Air Bracket on 87 - up Cast Iron Heads **NO DRILLING REQUIRED**  
#12209001..... V-Belt  
#12219001..... Serpentine

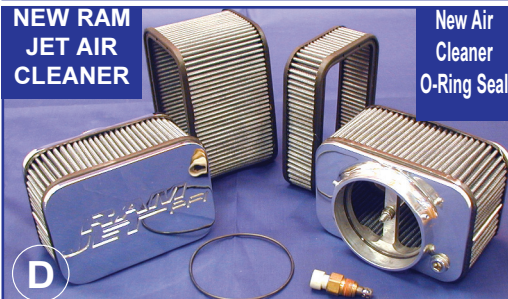

Comes w/ O-ring Seal; optional Air Temp Hole. Air Temp is only needed with closed loop system.  
Replacement elements available

	Natural	Polished	Chromed
00009483 w/ 1 3/4" Filter	135.95	156.95	177.95
00009484 w/ 1 1/2" Filter	135.95	156.95	177.95
00009485 w/ 3" Filter	135.95	156.95	177.95
00009486 w/ 4" Filter	135.95	156.95	177.95
00000029 Replacement O-Ring	3.95	N/A	N/A
70036979 Air Temp Sensor	22.99	N/A	33.99

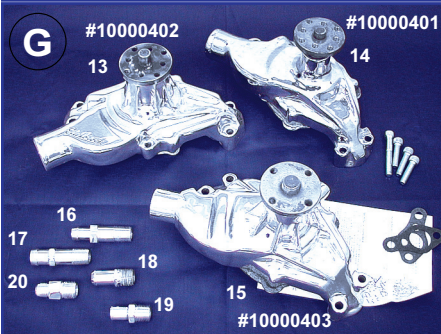

#10000402, #10000403, #10000401

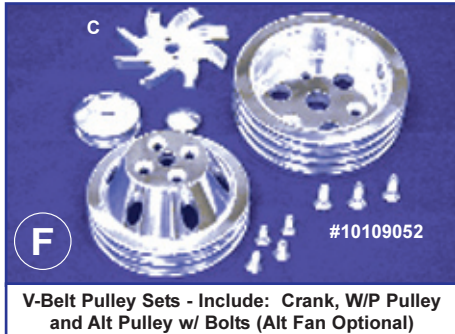

V-Belt Pulley Sets - Include: Crank, W/P Pulley and Alt Pulley w/ Bolts (Alt Fan Optional)



#00009400 Alum P/S Reservoir, #00000401





Kit fits 87 later Iron Heads & some aftermarket Alum. Heads

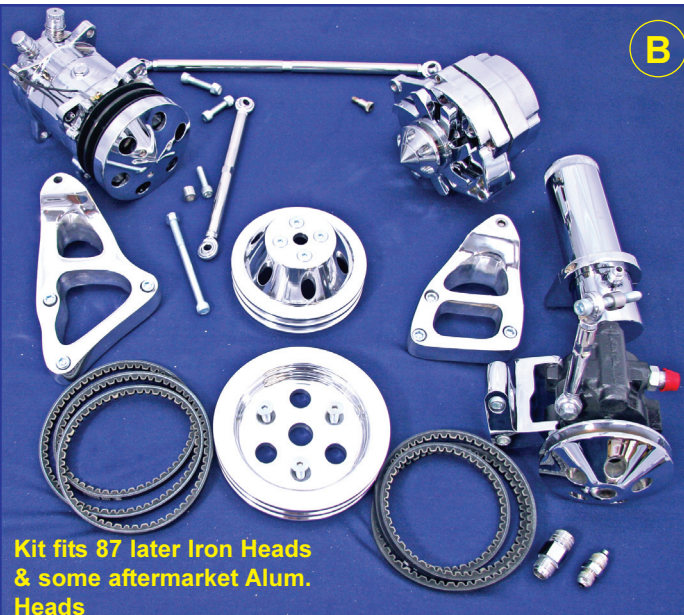

Kit fits 87 later Iron Heads & some aftermarket Alum. Heads

**SWP RAMJET ALT/AIR V-BELT BRACKET AND BAR KIT**  
 Complete Bracket Kits (as pictured) includes, Pulley Set, Idler Kit, PS Kit, GM 1 Wire 90 Amp Alternator, 508 Sanden Compressor, Alum. Alt Fan, 508 Front Cover, all Mounting Bolts, and V-Belts. *(Any item that you already have can be removed from the package and price reduced.)*

Part #	Small Block Ram Jet Alt & Air With Power Steering	Polished	Chrome
A.	Alt & Air Kit with Type II P.S Pump (Kit fits 87 Later Iron Heads) & some aftermarket Aluminum Heads. ....	1610.95	1849.95
B.	Alt & Air Kit with Type I P.S Pump (Kit fits 87 later Iron Heads) & some aftermarket Alum Heads. ....	1594.95	1833.95
C.	Alt & Air Kit NO P.S (Kit fits 87 Later Iron Heads) some aftermarket Aluminum Heads. ....	1107.95	1287.95
<b>Alt ONLY Driver Side</b>			
D.	Alt Only .....	619.95	743.95

Part#	TPI Accessories	Polished	Chrome
A.	SBC Fuel Pump Block Off	38.95	48.95
B.	1/2" Pipe Long 3/4" Hose Bib <i>(for water pump)</i>	19.49	21.49
C.	1/2" Pipe Long 5/8" Hose Bib <i>(for water pump)</i>	19.49	21.49
D.	1/2" Pipe Short 5/8" Hose Bib	17.49	20.49
E.	1/2" Pipe 90 5/8" Hose Bib	17.49	20.49

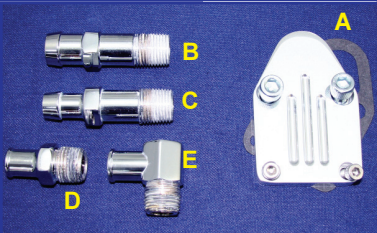

**ALT ONLY KIT**

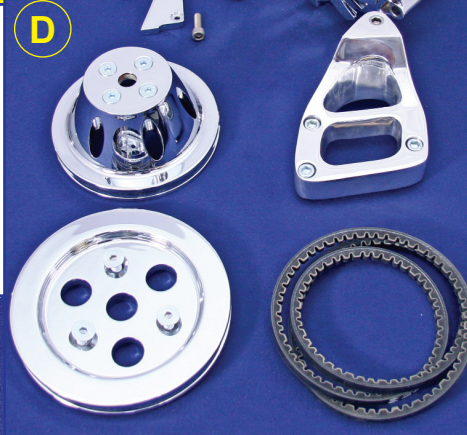

**All GM Driver Side Heads Have The Same Bolt Pattern**



Kit fits 87 later Iron Heads & some aftermarket Alum. Heads

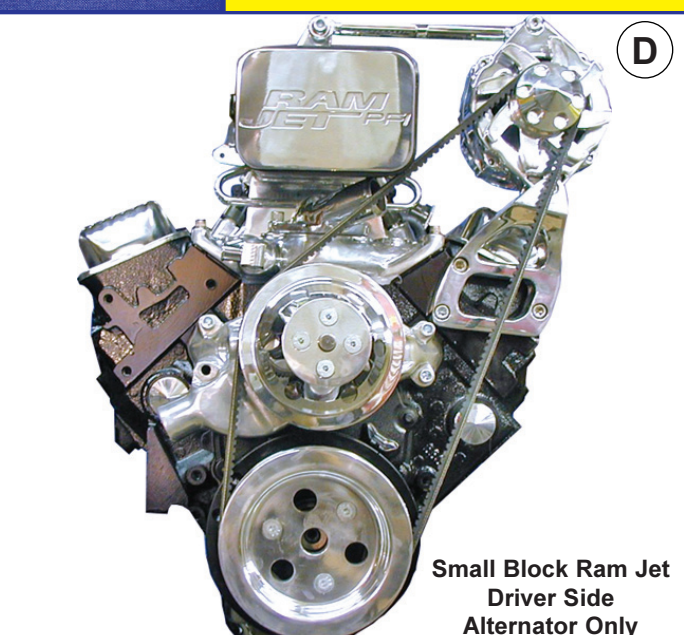

Small Block Ram Jet Driver Side Alternator Only

23  
 SBC Ramjet Street Rod Style Bracket - V-Belt  
 23



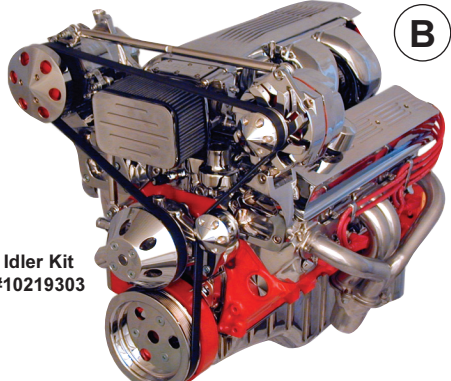

**(B)**

Idler Kit  
#10219303

**S/B GM FUEL INJECTION STREET ROD STYLE**  
Driver Side Alt/ Pass Air w/o P/S, Lg. Alt, (1) Smooth Idler Pulley Driver Side & Serpentine Pulley Set



**(A)**

**Kit Highlighted in BLUE Pricing**

#10119051

#10219303

#10019103

**S/B GM TPI WITH SHORT STREET ROD STYLE BRACKETRY**  
Driver Side Alt / Pass Side Air w/Type III P/S, w/Lg GM Alt, (1) Smooth Idler Pulley Driver Side and Serpentine Pulley Set

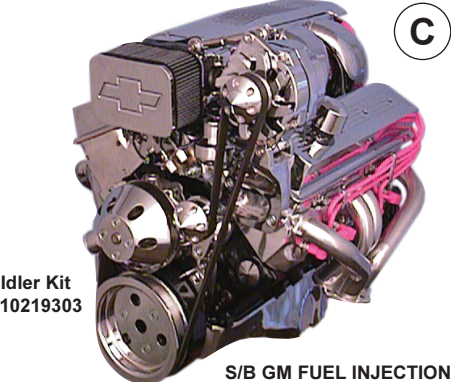

**(C)**

Idler Kit  
#10219303

**S/B GM FUEL INJECTION STREET ROD STYLE**  
Driver Side Alt (only), GM TPI, Lg Tubes, (1) Smooth Idler Pulley Driver Side & Serpentine Pulley Set



Fan Optional

**(D)**

#10119051  
SBC Serp. Pulley Set w/ Smooth Vette W/Pump Pulley 3/4" Shaft

# 00000007  
Large Aluminum Alternator Fan (Optional)



Fan Optional

**(E)**

#10119053  
SBC Serp. Pulley Set w/ Smooth W/Pump Pulley 5/8" Shaft



Fan Optional

**(F)**

#10119054  
SBC Serp. Pulley Set w/ Ribbed W/Pump Pulley 5/8" Shaft (Used for Alt Only)

Part #	STREET ROD STYLE SERPENTINE BRACKET KITS	Natural	Polished	Chrome
Includes: Bracket, Adjusting Bars and Bolts				
10219001	Short Alt Driver Side & Air Pass Side Serpentine Kit . . . . .	295.95	329.95	350.95
12219001	Short Alt D/Side & Air P/Side Serp 87-up Cast Iron Head . . . . .	307.95	341.95	371.95
10219031	Tall Alt Driver Side & Air Passenger Side Serpentine Kit . . . . .	307.95	341.95	371.95
10209003	Short Alt (only) Driver Side Serpentine Kit . . . . .	196.95	206.95	243.95
10209032	Tall Alt (only) Driver Side Serpentine Kit . . . . .	218.95	229.95	263.95
STREET ROD STYLE ALT AND AIR BRACKETS				
10202001	Short Alt (only) Driver Side Bracket . . . . .	96.95	106.95	124.95
10202006	Short Air (only) Passenger Side Serp Bracket . . . . .	96.95	106.95	124.95
12202006	Short Air Only P/Side Serp 87-up Cast Iron Head . . . . .	106.95	117.95	135.95
10202033	Tall Air (only) Passenger Side Bracket . . . . .	109.95	120.95	137.95
10202034	Tall Alternator (only) Bracket . . . . .	109.95	120.95	137.95
00000001	10 O'Clock Alternator Adapter Bracket for Driver Side . . . . .	N/A	27.95	38.95
STAINLESS ADJUSTER BARS				
10109123	Alt Only 4" Heim End Bar . . . . .	N/A	55.95	N/A
10109124	Alt to Air 13 1/2" Heim End Bar . . . . .	N/A	55.95	N/A
10109117	Air to W/P 7" (Short Bracket) Heim End Bar . . . . .	N/A	55.95	N/A
10109126	Air to W/P 8" (Tall Bracket) Heim End Bar . . . . .	N/A	55.95	N/A
10109127	2 - Heim End Bars (Short Bracket) Alt to Air, Air to W/P . . . . .	N/A	111.95	N/A
10109125	2 - Heim End Bars (Tall Bracket) Alt to Air, Air to W/P . . . . .	N/A	111.95	N/A
10109128	2 - Heim End Bars Air to Idler, Alt to Idler . . . . .	N/A	111.95	N/A
SERPENTINE ACCESSORIES				
10000402	16. Aluminum Edelbrock Short Water Pump - 5/8" Pilot . . . . .	223.95	301.95	N/A
10110403	17. Aluminum Vette Short Water Pump - 3/4" Pilot . . . . .	157.95	212.95	N/A
10000401	(Chrome) Steel GM Factory Short Water Pump . . . . .	N/A	N/A	135.95
10119051	Serp Pulley Set (Crank, W/P & Alt for Vette 3/4" Pilot W/P . . . . .	N/A	273.95	317.95
10119052	Serp Pulley Set (Crank, Alt w/ Ribbed W/P w/Vette 3/4" Pilot . . . . .	N/A	273.95	317.95
10119053	Serp Pulley Set (Crank, Alt w/ Smooth W/P w/ 5/8" Pilot . . . . .	N/A	273.95	317.95
10119054	Serp Pulley Set (Crank, Alt w/ Ribbed W/P w/ 5/8" Pilot . . . . .	N/A	273.95	317.95
BRACKETS WITH IDLERS				
10219303	TPI Driver Side Single Smooth Idler w/ Bracket . . . . .	N/A	134.95	151.95
10219308	TPI Short 4 Idler Bracket Kit (2 Brackets, 4 Idlers) . . . . .	N/A	412.95	463.95
10219309	TPI Tall 4 Idler Bracket Kit (2 Brackets, 4 Idlers) . . . . .	N/A	424.95	473.95

**S/B WATER PUMPS**



**(G)**

See Page 9 for Hose Bid Pricing

#10110403

**A/C COMPRESSORS**

See Pg. 49

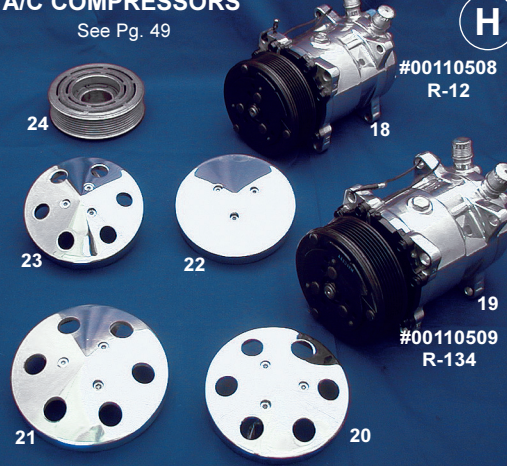

**(H)**

#00110508 R-12

#00110509 R-134



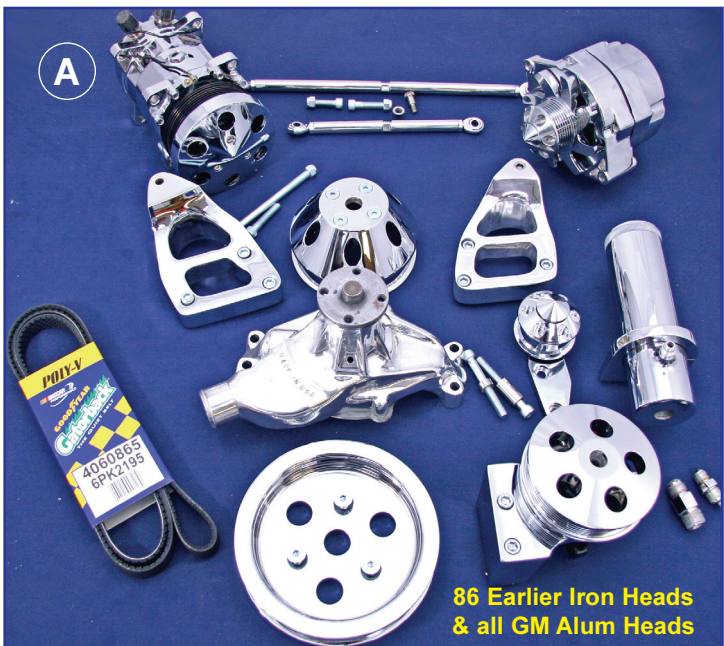

**86 Earlier Iron Heads & all GM Alum Heads**

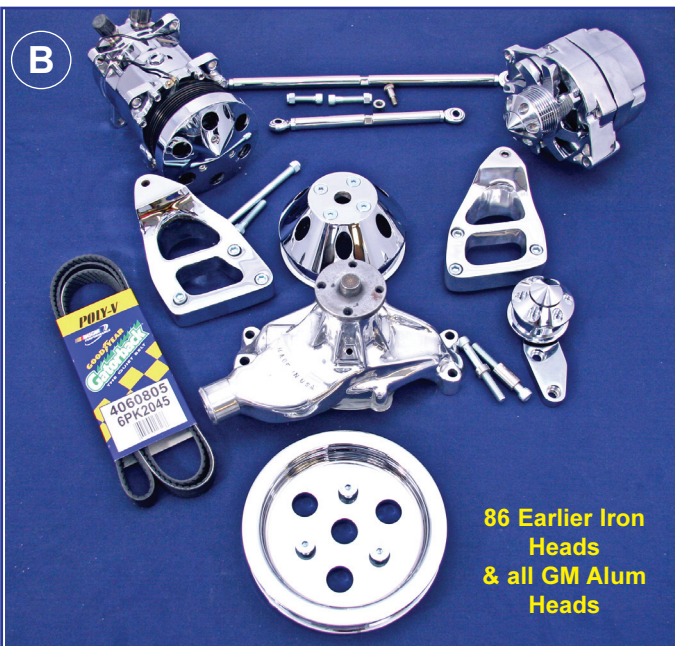

**86 Earlier Iron Heads & all GM Alum Heads**

**Complete Bracket Kits (as pictured)** includes, Water Pump, Pulley Set, Idler Kit, PS Kit, GM 1 Wire 90 Amp Alternator, 508 Sanden Compressor, Alum. Alt Fan, 508 Front Cover, all Mounting Bolts, Gaskets and Belt. **(Any item that you already have can be removed from the package and price reduced.)**

Part #		Polished	Chrome
A.	Alt, Air & PS Package - Alum. & '86 earlier Iron	1956.95	2214.95
B.	Alt, Air No PS Package - Alum. & '86 earlier Iron	1485.95	1683.95
C.	Alt ONLY Kit	699.95	822.95
E.	Alt, Air & PS Package - '87 up Cast Iron / Vortec	1967.95	2225.95
F.	Alt, Air No PS Package - '87 up Cast Iron / Vortec	1496.95	1694.95

Part#	TPI Accessories	Polished	Chrome
A.	SBC Fuel Pump Block Off	38.95	48.95
B.	1/2" Pipe Long 3/4" Hose Bib (for water pump)	19.49	21.49
C.	1/2" Pipe Long 5/8" Hose Bib (for water pump)	19.49	21.49
D.	1/2" Pipe Short 5/8" Hose Bib	17.49	20.49
E.	1/2" Pipe 90 5/8" Hose Bib	17.49	20.49
F.	TPI Offset Water Neck w/ Bolts & O-ring Gasket	81.95	92.95
G.	TPI Water Neck Gasket	5.00	N/A

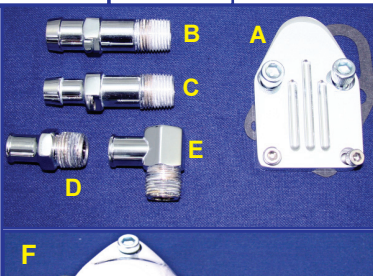

**All GM Driver Side Heads Have The Same Bolt Pattern**

**TPI OFFSET WATER NECK** a must for Early Street Rods with tight clearance!



**Kit fits '87 later Iron Heads & some aftermarket Alum. Heads**

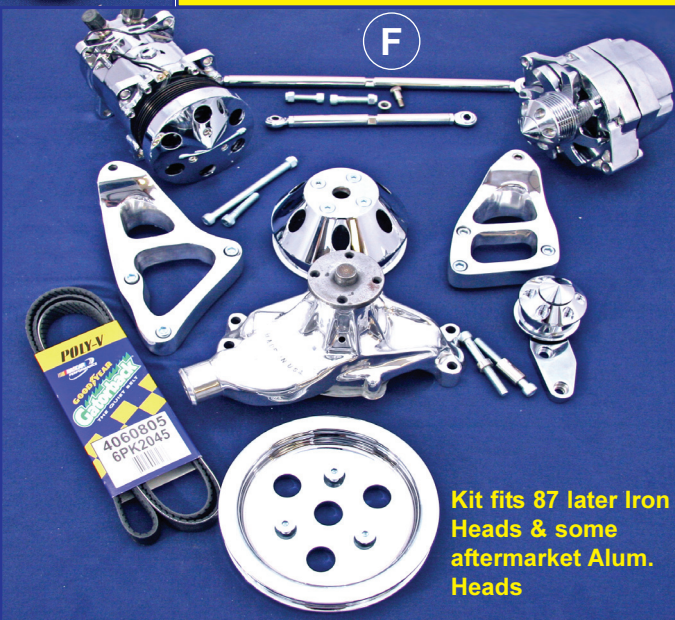

**Kit fits '87 later Iron Heads & some aftermarket Alum. Heads**



**(A)**

**Kit Highlighted in Blue Pricing**

**#10219308**

**S/B WITH S&P MULTI-PORT INJECTION STREET ROD STYLE BRACKETRY**  
Driver Side Alt/Pass Air w/Type III P/S, Large Alt w/ 10 O'Clock Adapter, (4) Idler Pulleys and Serpentine Belt Set-up

**(B)**

**#10219309**

**RAM PORT FUEL INJECTION STREET ROD STYLE**  
Driver Side Alt / Pass Side Air w/o P/S, using Lg GM Alt, 4 Idler Pulleys and Serp Pulley Set

**(I)**

**#10219001**

The Tuned Port Injection Alternator/Air Kit, is designed for the Vette Short Water Pump - 3/4" Shaft and the Standard Short Water Pump - 5/8" Shaft.

The yellow motor shown on page 16, pictured Street Rod Style, is our most popular set-up with the belt and bar over the top of the air cleaner. The Street Rod Style is ideal for vehicles w/ no side clearance such as street rods, jeeps, early 50's with narrow engine compartments and 57's with original battery box location.

The red motor shown above, features the dual idler set-up and is a must when the bar & belt cannot go over the top. This set up can be used in the 57 Chevy when battery is in original location. **(MUST USE L98 RADIATOR "T" W/ DUAL IDLER SET)**

**(C)**

**#10219309**

**STREET ROD STYLE**  
Driver Side Alt, Pass Side Air w/o P/S, w/ Lg GM Alt w/ 10 O'Clock Adapter, 4 Idler Pulleys and Serp. Pulley Set

**TPI LONG WATER PUMP SPACER KITS FOR STREET ROD APPLICATIONS (V-Belt only)**

**#11209001**

This spacer kit allows you to space alt/air or alt only outward for long water pump applications. Can also be used with blower application. Special Spacers made for other applications.  
Polished \$42.95 ea  
Chromed \$57.95 ea

**Ram Jet can run with or without bar across top**

**(D)**

**#10019104**

**THIS APPLICATION IS USED W/ FRONT MOTOR MOUNTS AS IN THE '55-'57 CHEVY'S**

**S&P FUEL INJECTION**  
Driver Side Alternator / Passenger Side Air using Type IV P/Steering, with Lg. GM Alternator & 10 O'Clock Adapter, (3) Idler Pulleys and Serp. Pulley Set

**(F)**

**#10219308**

**#10119051**  
Fan Optional

**#10019103**

**RAM JET STREET ROD STYLE**  
Driver Side Alternator / Passenger Side Air using Type III Power Steering.

**(E)**

**#12219001**

No Drilling Required For 87-up Cast Iron Heads

**RAM JET STREET ROD STYLE**  
Driver Side Alt / Pass Side Air w/out Power Steering.

Also Available w/ Type III Power Steering



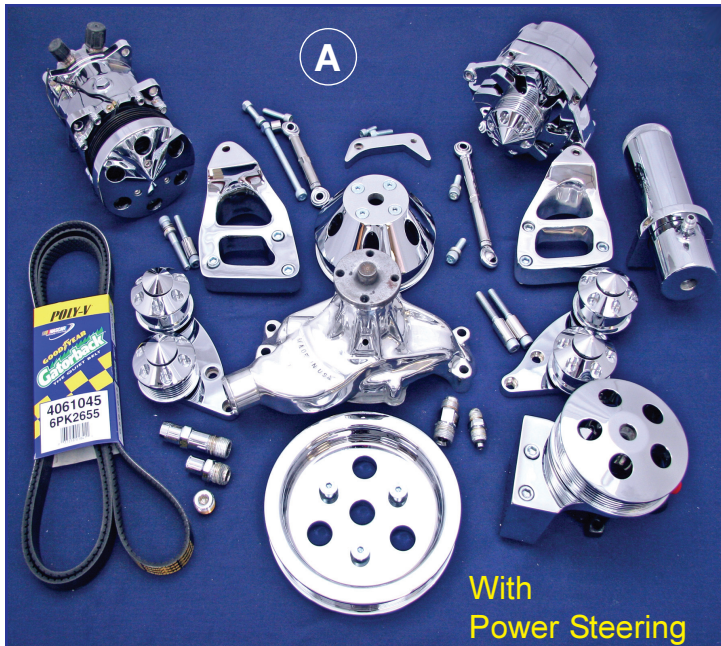

With Power Steering



Without Power Steering

Part #	STREET ROD STYLE SERPENTINE BRACKET KITS	Natural	Polished	Chrome
	Includes: Bracket, Adjusting Bars and Bolts			
10219001	Short Alt Driver Side & Air Pass Side Serpentine Kit	285.95	317.95	350.95
12219001	Short Alt D/Side & Air P/Side Serp 87-up Cast Iron Head	296.95	329.95	371.95
10219031	Tall Alt Driver Side & Air Passenger Side Serpentine Kit	296.95	329.95	371.95
10209003	Short Alt (only) Driver Side Serpentine Kit	189.95	199.95	243.95
10209032	Tall Alt (only) Driver Side Serpentine Kit	210.95	221.95	263.95
	STREET ROD STYLE ALT AND AIR BRACKETS			
10202001	Short Alt (only) Driver Side Bracket	102.95	113.95	135.95
10202006	Short Air (only) Passenger Side Serp Bracket	102.95	113.95	135.95
12202006	Short Air Only P/Side Serp 87-up Cast Iron Head	113.95	124.95	145.95
10202033	Tall Air (only) Passenger Side Bracket	105.95	116.95	137.95
10202034	Tall Alternator (only) Bracket	105.95	116.95	137.95
00000001	10 O'Clock Alternator Adapter Bracket for Driver Side	N/A	26.95	38.95
	STAINLESS ADJUSTER BARS			
10109123	Alt Only 4" Heim End Bar	N/A	53.95	N/A
10109124	Alt to Air 13 1/2" Heim End Bar	N/A	53.95	N/A
10109117	Air to W/P 7" (Short Bracket) Heim End Bar	N/A	53.95	N/A
10109126	Air to W/P 8" (Tall Bracket) Heim End Bar	N/A	53.95	N/A
10109127	2 - Heim End Bars (Short Bracket) Alt to Air, Air to W/P	N/A	107.95	N/A
10109125	2 - Heim End Bars (Tall Bracket) Alt to Air, Air to W/P	N/A	107.95	N/A
10109128	2 - Heim End Bars Air to Idler, Alt to Idler	N/A	107.95	N/A
	SERPENTINE ACCESSORIES			
10000402	16. Aluminum Edelbrock Short Water Pump - 5/8" Pilot	215.95	290.95	N/A
10110403	17. Aluminum Vette Short Water Pump - 3/4" Pilot	151.95	207.95	N/A
10000401	(Chrome) Steel GM Factory Short Water Pump	N/A	N/A	135.95
10119051	Serp Pulley Set (Crank, W/P & Alt for Vette 3/4" Pilot W/P	N/A	263.95	317.95
10119052	Serp Pulley Set (Crank, Alt w/ Ribbed W/P w/Vette 3/4" Pilot	N/A	263.95	317.95
10119053	Serp Pulley Set (Crank, Alt w/ Smooth W/P w/ 5/8" Pilot	N/A	263.95	317.95
10119054	Serp Pulley Set (Crank, Alt w/ Ribbed W/P w/ 5/8" Pilot	N/A	263.95	317.95
10019103	Type III Power Steering kit for Serpentine	290.95	302.95	322.95

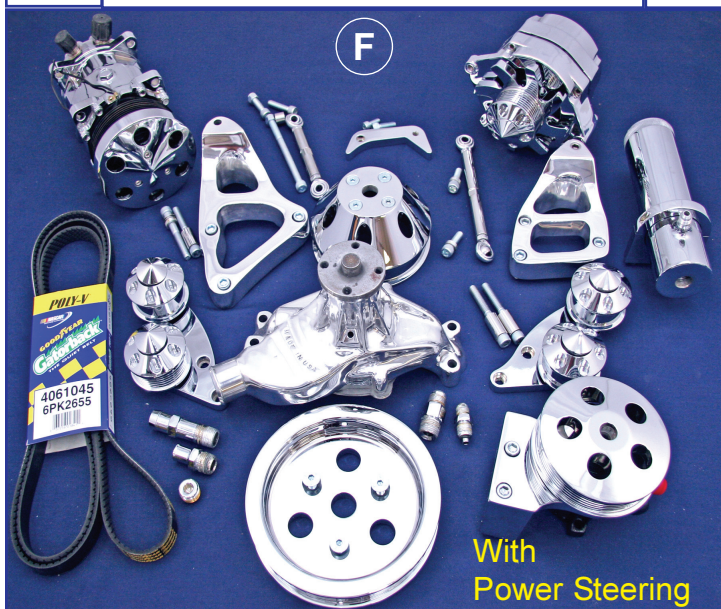

With Power Steering



Without Power Steering



Lower Heater Tee and Plug #00000016 See pg. 31

Complete Bracket Kits (as pictured) includes, Water Pump, Pulley Set, Idler Kit, PS Kit, GM 1 Wire 90 Amp Alternator, 508 Sanden Compressor, Alum. Alt Fan, 508 Front Cover, all Mounting Bolts, Gaskets and GoodYear Gatorback Belt.

Part #		Polished	Chrome
	A. Alt, Air & PS Package	2209.95	2510.95
	C. Alt, Air No PS Package	1738.95	1979.95
	E. Alt, Air & PS Package 87	2220.95	2521.95
	F. Alt, Air No PS Package 87	1743.95	1990.95
	BRACKETS WITH IDLERS	Polished	Chrome
10219303	TPI Driver Side Single Smooth Idler w/ Bracket	118.95	140.95
10219308	TPI Short 4 Idler Bracket Kit (2 Brackets, 4 Idlers)	398.95	463.95
10219309	TPI Tall 4 Idler Bracket Kit (2 Brackets, 4 Idlers)	405.95	473.95

27
  
 SBC (TPI) Street Rod Style Bracket - SERPENTINE
   
27



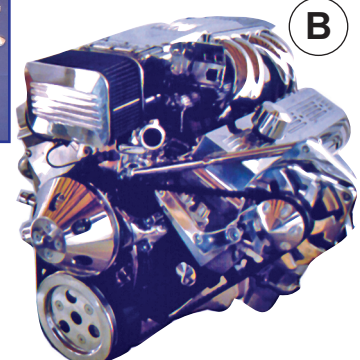

**B**

#10109050

**GM FUEL INJECTION VETTE/CAMARO STYLE**  
Driver Side Alternator (Only)  
w/out Power Steering, using Large GM Alternator  
w/ 10 O'Clock Adapter, SWP and 1-Gr. Pulley Set

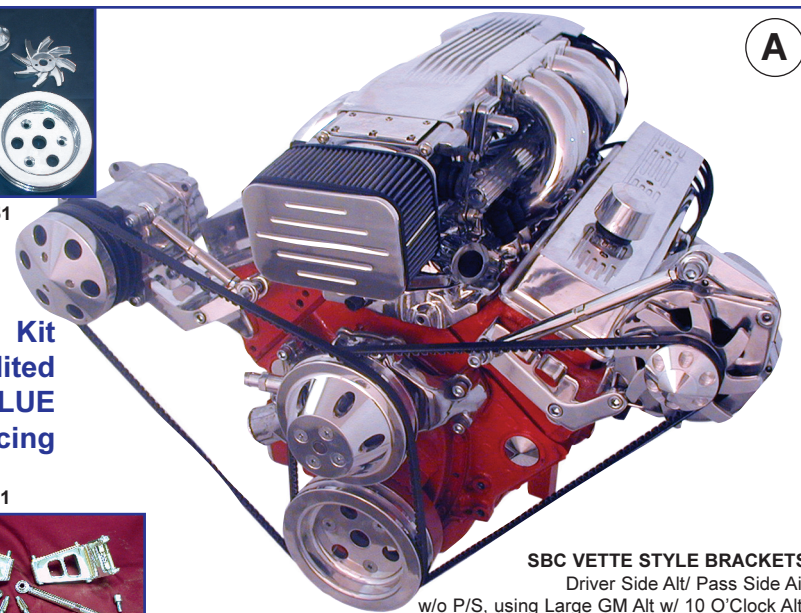

**A**

#10109051

**Kit Highlighted in BLUE Pricing**

**SBC VETTE STYLE BRACKETS**  
Driver Side Alt/ Pass Side Air  
w/o P/S, using Large GM Alt w/ 10 O'Clock Alt,  
V-Belt Pulley Set w/ 2-Groove Crank

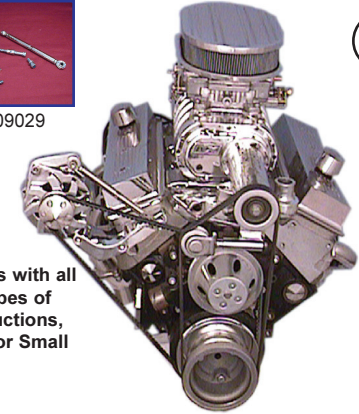

**C**

#10909029

**B&M BLOWER VETTE/CAMARO STYLE**  
Pass Side Alt (Only) w/o P/S, Lg. Alt w/ 2 O'Clock  
Adapter, SWP, and 1-Gr. V-Belt Pulley Set

Works with all Types of Inductions, Big or Small



#10009051

Part#	VETTE/CAMARO SWP V-BELT BRACKET KITS Includes: SS Adjuster Bar, Bolts w/out 10 O'Clock Adapter	Natural	Polished	Chrome
10909001	SWP Driver Side Alt/Pass Side Air Kit	280.95	302.95	355.95
10909002	SWP Pass Side Alt/Driver Side Air Kit	290.95	312.95	376.95
10909028	SWP Driver Side Alt (only) Kit (Inc. 10 O'Clock Adapter)	167.95	177.95	215.95
10909004	SWP Pass Side Alt (only) Kit (Inc. 2 O'Clock Adapter)	172.95	183.95	226.95
<b>VETTE/CAMARO SWP V-BELT ALT &amp; AIR BRACKETS</b>				
10902001	SWP Alternator (only) Driver Side Bracket	86.95	98.95	124.95
10902002	SWP Alternator (only) Passenger Side Bracket	92.95	102.95	135.95
10902004	SWP Air (only) Driver Side Bracket	92.95	102.95	135.95
10902006	SWP Air (only) Passenger Side Bracket	86.95	98.95	124.95
00000001	10 O'Clock Alternator Adapter Bracket for Driver Side	N/A	26.95	38.95
00000002	2 O'Clock Alternator Adapter Bracket for Passenger Side	N/A	26.95	38.95
<b>VETTE/CAMARO SWP V-BELT ADJ BAR KIT &amp; ACCES</b>				
10905916	SWP Driver Side Alternator (only) Bar Kit	N/A	53.95	N/A
10905917	SWP Passenger Side Air (only) Bar Kit	N/A	53.95	N/A
10905918	SWP Alternator/Air Adjuster Bar Kit	N/A	107.95	N/A
10905919	SWP Pass Alternator (only) Adjuster Bar Kit	N/A	53.95	N/A
10109051	SB SWP 2-Gr. Pulley Set (Crank, W/P & Alt)	N/A	209.95	268.95
10109050	SB SWP 1-Gr. Pulley Set (Crank, W/P & Alt)	N/A	203.95	262.95



**D**

#10909030

**CARBURETOR VETTE/CAMARO STYLE**  
Driver Side Air / Passenger Side Alternator  
w/out P/Steering, using Lg. GM Alternator w/ 10 O'Clock  
Adapter, and V-Belt Pulley Set. Can be run w/ Type I P/S

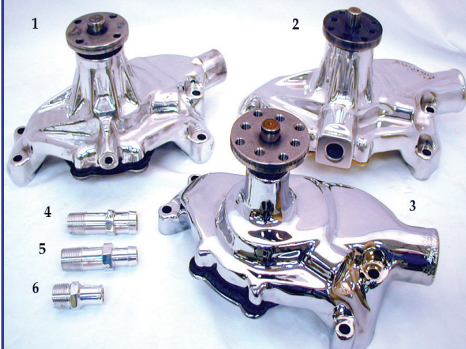

	Polished	Chrome
1. GM Reverse Flow Vette Short W/Pump 3/4" Pilot	204.95	N/A
1a. Edelbrock Reverse Flow Vette Short W/Pump 3/4" Pilot	290.95	N/A
2. Edelbrock Standard Rotation Short W/P 5/8" Pilot	290.95	N/A
3. Chrome GM Standard Rotation Short W/Pump 5/8"	N/A	135.95
4. Long Polished Aluminum 1/2" to 3/4" Hose Bib	19.49	21.49
5. Long Polished Aluminum 1/2" to 5/8" Hose Bib	19.49	21.49
6. Short Polished Aluminum 1/2" Pipe to 5/8" Hose Bib	17.48	20.49



**E**

#10909028

**STREET BLOWER VETTE/CAMARO STYLE**  
Driver Side Alternator (Only)  
w/out P/Steering, using Lg. GM Alternator w/ 10 O'Clock  
Adapter, SWP and V-Belt Pulley Set w/ 2-Gr. Crank

Works with all Types of Inductions

For Alternator Information and Pricing See Page 48

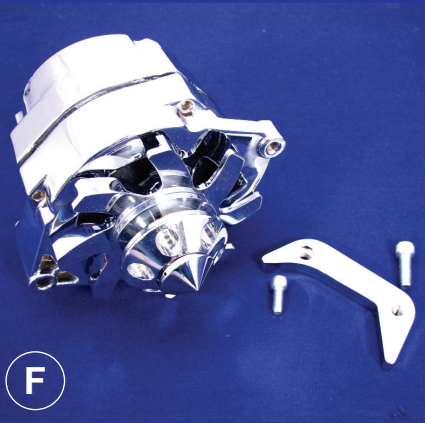

**F**

For Air Compressors Information and Pricing see page 49



**G**

AC Aluminum Hard Line Kit for R12 or 134. See page 87



**B**

Part # 11009102

#11909027

Kit Highlighted in BLUE Pricing #11109052

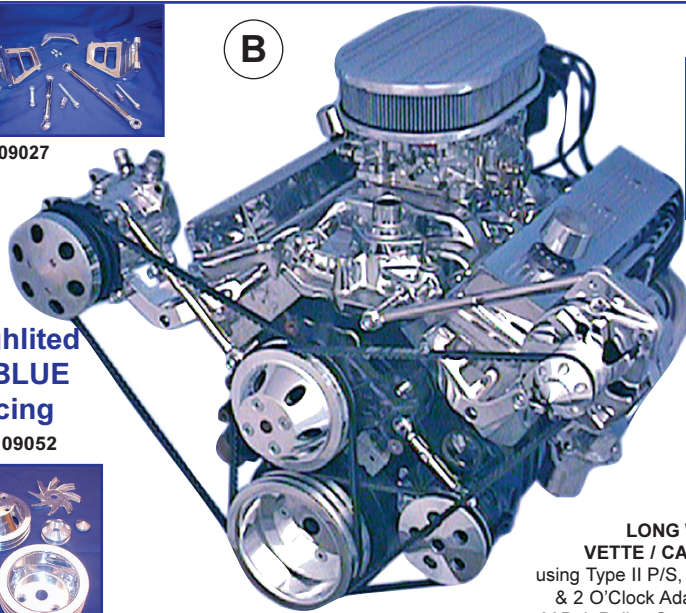

2 Groove Alt Pulley is needed for Power Steering

**LONG WATER PUMP VETTE / CAMARO STYLE**  
using Type II P/S, with Lg GM Alt & 2 O'Clock Adapter, LWP and V-Belt Pulley Set w/ 3-Gr. Crank



**Long Water Pump Pulleys**

Part#		Polished	Chrome
00000007	1. Lg. Alum Alternator Fan	43.95	53.95
00000008	2. Sm. Alum Alternator Fan	43.95	53.95
00001001	3. Alum 2-Gr. LWP Pulley	97.95	122.95
11001003	4. Alum 2-Gr. LWP Crank Pulley	112.95	155.95
11001004	5. Alum 3-Gr. LWP Crank Pulley	132.95	181.95
00001002	6. Alum 1-Gr. LWP W/P Pulley	92.95	115.95
00000032	7. Alum 2-Gr. Alternator Pulley	46.95	56.95
00000031	8. Alum 1-Gr. Alternator Pulley	35.95	46.95
00000020	9. Alum Alt Button (N/C w/ Pulley)	8.95	11.95

Part#	VETTE/CAMARO LWP V-BELT BRACKET KITS Includes: SS Adjuster Bar & Bolts, w/out 10 O'Clock Adapter	Natural	Polished	Chrome
11909027	LWP Driver Side Alt/Pass Side Air Kit	302.95	322.95	366.95
11909028	LWP Driver Side Alt (only) Kit (Incl.: 10 O'Clock Adapter) <b>VETTE/CAMARO LWP V-BELT ALT &amp; AIR BRACKETS</b>	178.95	188.95	221.95
11902001	LWP Alternator (only) Driver Side Bracket	97.95	108.95	129.95
11902004	LWP Air (only) Passenger Side Bracket	97.95	108.95	129.95
00000001	10 O'Clock Alternator Adapter Bracket for Driver Side	N/A	26.95	38.95
00000002	2 O'Clock Alternator Adapter Bracket for Passenger Side <b>VETTE/CAMARO LWP V-BELT ADJ BAR KIT &amp; ACCES</b>	N/A	26.95	38.95
11905916	LWP Driver Side Alternator (only) Bar Kit	N/A	53.95	N/A
11905917	LWP Passenger Side Air (only) Bar Kit	N/A	53.95	N/A
11905918	LWP Alternator/Air Adjuster Bar Kit	N/A	107.95	N/A
11109051	SB LWP 2-Gr. Pulley Set (Crank, W/P Pulley, & Alt Pulley)	N/A	236.95	317.95
11109052	SB LWP 3-Gr. Pulley Set (Crank, W/P Pulley, & Alt Pulley)	N/A	256.95	339.95
11009102	SB Type II Power Steering V-Belt on Long Water	290.95	322.95	344.95

#11109052

**F**



Long Water Pump w/ 2 Gr. Water Pump Pulley and 3-Gr. Crank Pulley used w/ Alternator/Air, And Type II Power Steering

**Water Pump Information**  
See Page 12



#11909027

**C**



#11109051

**G**



Long Water Pump w/ 2 Gr. Water Pump Pulley and 2-Gr. Crank Pulley used w/ Alternator/Air

#11909027

#11109051

**A**

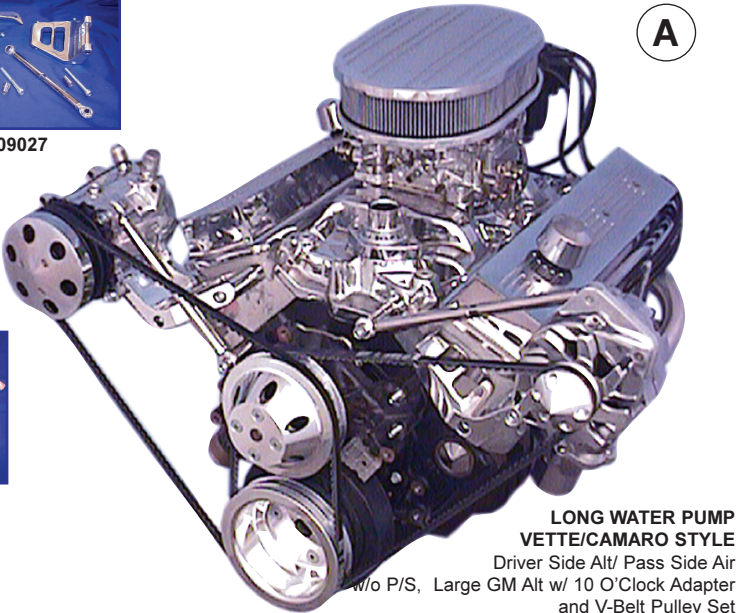

**LONG WATER PUMP VETTE/CAMARO STYLE**  
Driver Side Alt/ Pass Side Air w/o P/S, Large GM Alt w/ 10 O'Clock Adapter and V-Belt Pulley Set

**Edelbrock Long Water Pump**

**H**



Fits all '69-'87 SBC and '73-'86 Light Duty Trucks 6-15/16" surface to hub w/ 5/8" pilot; can be used on any SBC engine that has room for LWP and accessories.

#11000402	Unpolished	215.95
#11000402	Polished	290.95

SBC Vette/Camaro Long Water Pump (LWP) - V-Belt



NOTE: THIS KIT WORKS GREAT IN 50'S AND LATER MODEL VEHICLES. WILL NOT WORK ON '57 CHEVROLET'S THAT HAVE THE BATTERY BOX IN STOCK LOCATION!

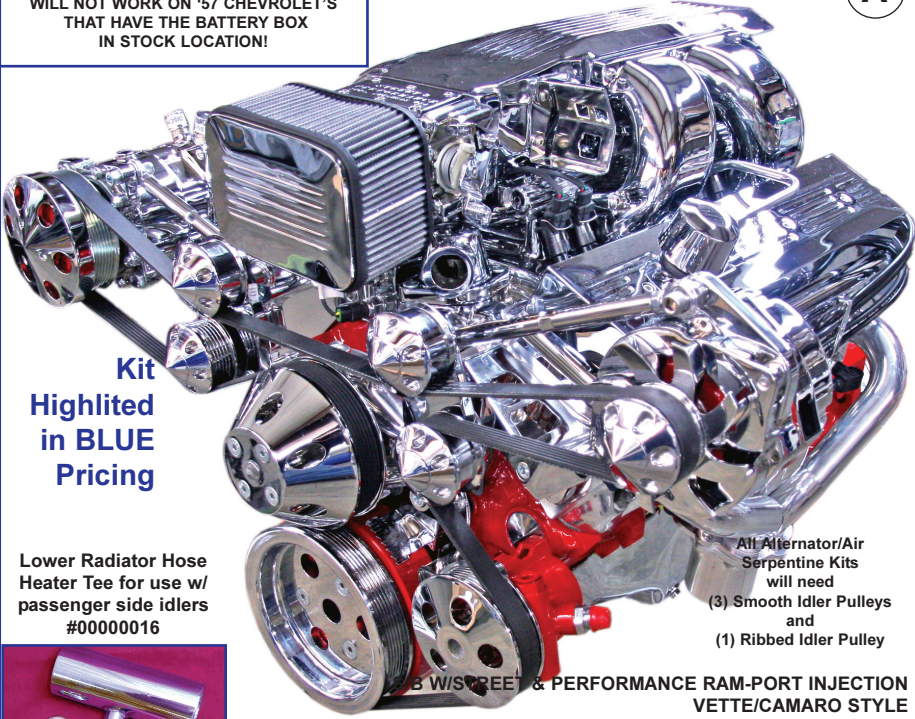

**Kit Highlighted in BLUE Pricing**

Lower Radiator Hose Heater Tee for use w/ passenger side idlers #00000016



All Alternator/Air Serpentine Kits will need  
(3) Smooth Idler Pulleys and  
(1) Ribbed Idler Pulley

**SBC W/STREET & PERFORMANCE RAM-PORT INJECTION VETTE/CAMARO STYLE**  
Driver Side Alt / Pass Side Air using Type III P/S, Lg GM Alt w/ 10 O'Clock Adapter and Serp Pulley Set

**(B)**

#10019103

**RAM JET 350 w/ VORTEC HEADS**  
This bracket kit works great w/ either V-Belt or Serpentine on the "New" Vortec and Fast Burn Heads

**(C)**

#10919003      #10119203

**SBC VETTE/CAMARO STYLE**  
Driver Side Alt / Passenger Side Air w/out P/S, P/S can be added later.

**(D)**

#10919017

**Serpentine Vette Style Alt/PS**

**VETTE/CAMARO STYLE**  
Driver Side Alternator (Only) using Type III Power Steering

**(E)**

#10919015

**SBC VETTE/CAMARO**  
w/out Power Steering, using Large GM Alternator w/ 10 O'Clock Adapter and Serpentine Pulley Set

Part#	DESCRIPTION	Natural	Polished	Chrome
<b>VETTE SWP SERPENTINE BRACKET KITS</b>				
Inc. Adjuster Bar & Bolts.				
10969001	(A) Driver Side Alt/Pass Side Air Kit w/ 10 O'Clock Adapter	280.95	302.95	355.95
10119203	Driver Side Alt/Pass Side Air Kit w/ 10 O' Adapter	307.95	329.95	393.95
10915918	Complete Kit - Driver Side Alt/Pass Side Air Kit (Inc. 2 Idler Brackets and 4 Idlers NO 10 O'Clock Adapter)	677.95	699.95	807.95
10919018	Complete Kit -Driver Side Alt/Pass Side Air Kit w/10 O'Clock Adapter Inc. 2 Brackets and 4 Idlers	705.95	726.95	855.95
10909028	Driver Side Alt (only) Kit (Inc.: Bar/10 O'Clock Adapter)	167.95	177.95	215.95
10919015	Complete Kit - Alt Only Driver Side w/10 O'Clock Adapter, bar kit, dual idler bracket w/2 idlers	517.95	538.95	640.95
10919017	Complete Kit - Alt Only Driver Side w/10 O'Clock Adapter, bar kit, dual idler bracket w/2 idlers w/ power steering	818.95	839.95	963.95
10919004	Pass Side Alt (only) Kit (Inc.: 2 O'Clock Adapter)	172.95	183.95	226.95
10019103	Type III Power Steering Kits	290.95	302.95	322.95
00009400	S&P Aluminum Power Steering Reservoir w/Bracket	N/A	135.95	172.95
00000424	1/2" Pipe to #8 Fitting	N/A	17.49	20.49
<b>VETTE SWP SERPENTINE ALT &amp; AIR BRACKETS</b>				
10912001	Alternator (only) Driver Side Bracket	86.95	97.95	124.95
10912002	Alternator (only) Passenger Side Bracket	92.95	102.95	135.95
10912004	Air (only) Driver Side Bracket	92.95	102.95	135.95
10912006	Air (only) Passenger Side Bracket	86.95	97.95	124.95
00000001	10 O'Clock Alt Adapter Bracket for Driver Side	N/A	26.95	38.95
00000002	2 O'Clock Alt Adapter Bracket for Passenger Side	N/A	26.95	38.95
<b>VETTE SWP SERP ADJ BAR KIT &amp; ACCESSORIES</b>				
1091	Alternator/Air Adjuster Bar Kit	N/A	107.95	N/A
1091	Alternator (only) Adjuster Bar Kit	N/A	53.95	N/A
1091	Air (only) Adjuster Bar Kit	N/A	53.95	N/A
0000	***Polished SS Heim Ends (Add Per Bar)	N/A	11.95	N/A
<b>IDLER BRACKET KITS</b>				
10119203	Short 4 Idler Bracket Kit (2 Brackets, 4 Idlers)	N/A	398.95	463.95
1091	Alt/Power Steering (only) Idler Kit (1 Bracket, 2 Idlers)	N/A	210.95	248.95
1091	Alt Only Idler Kit (1 Bracket, 2 Idlers)	N/A	210.95	248.95
00000030	Idler Pulley (Smooth)	-	81.95	92.95
00000029	Idler Pulley (Ribbed)	-	81.95	92.95
00110508	18. 508 A/C Compressor R-12 (Serpentine)	226.95	280.95	334.95
00110509	19. 508 A/C Compressor R-134 (Serpentine)	226.95	280.95	334.95
00000011	20. 508 Type III Front Cover	-	53.95	65.95
00000012	21. Old Style Large 508 Type III Front Cover	-	65.95	75.95
00000013	22. 508 Type I Smooth Front Cover	-	53.95	65.95
00000014	23. 709 Type III Front Cover	-	61.95	70.95
00110510	24. Serpentine Clutch Assembly	102.95	-	-
00000701	GM 65 Amp Internal Regulated Alt w/o Fan & Pulley	70.95	118.95	134.95
00000702	GM 90 Amp Internal Regulated Alt w/o Fan & Pulley	86.95	134.95	151.95
00000703	GM 65 Amp External Regulated Alt w/o Fan & Pulley	70.95	118.95	134.95
00000704	GM 1-Wire 65 Amp Internal Regulated Alt w/o Fan & Pulley	81.95	134.95	145.95
00000705	GM 1-Wire 90 Amp Internal Regulated Alt w/o Fan & Pulley	97.95	146.95	161.95
00000706	GM Sm 12 O'Clock 95/105 Amp Intl Regulated Alt w/o Fan & Pulley	151.95	204.95	226.95
00000707	GM Sm 10 O'Clock 95/105 Amp Intl Regulated Alt w/o Fan Pulley	151.95	204.95	226.95
10119051	Serp Pulley Set (Crank, W/P & Alt for Vette 3/4" Pilot W/P Gatorback Serp. Belt for above kit)	N/A	263.95	317.95



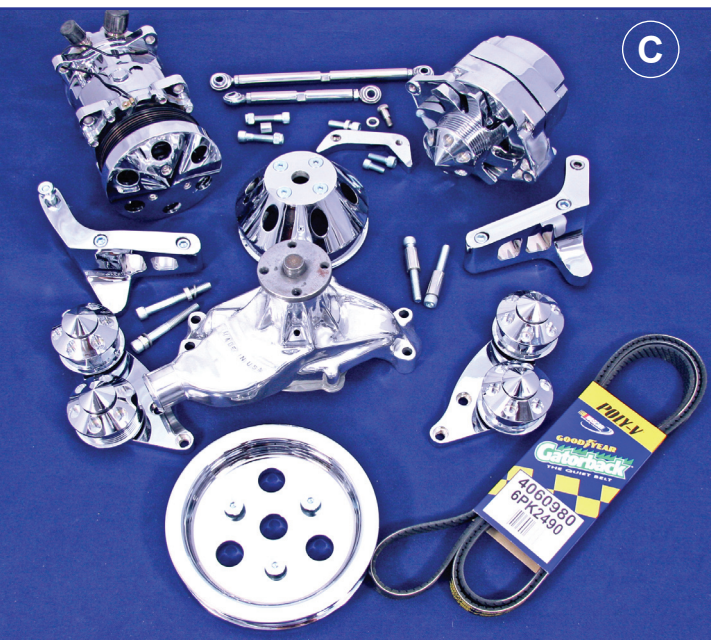
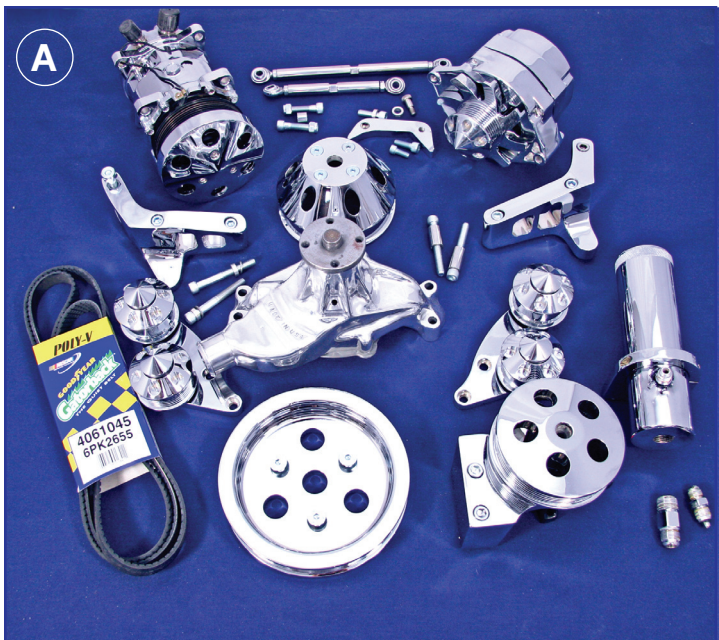

**SWP ALT/AIR SERPENTINE BRACKET AND BAR KIT**

Complete Bracket Kits (as pictured) includes, Water Pump, Pulley Set, Idler Kit, PS Kit, GM 1 Wire 90 Amp Alternator, 508 Sanden Compressor, Alum. Alt Fan, 508 Front Cover, all Mounting Bolts, and Belt. **(Any item that you already have can be removed from the package and price reduced.)**

Part #	50's & Later Wide Style Alt & Air With Power Steering	Polished	Chrome
A.	Alt & Air Kit with Type III P.S Pump.....	2322.95	2655.95
C.	Alt & Air Kit (NO Power Steering).....	1851.95	2124.95
<b>Alt &amp; Power Steering ONLY</b>			
D.	Alt ONLY Kit with Type III P.S Pump.....	1223.95	1406.95
<b>Alt ONLY Driver Side</b>			
E.	Alt Only.....	752.95	875.95



**SS Lower Radiator "T"**  
for returning Heater Hose into lower Radiator Hose  
Unpolished or Polished  
Unpol .00000016 . .33.95  
Pol . .00000016 . .40.95  
Plug .00000425 . .6.95

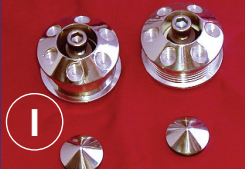

**Idler Pulleys for Serpentine Belt Set-up**  
Pol Smooth . .00000030  
Chr Smooth . .00000000  
Pol Ribbed . .00000031  
Chr Ribbed . .00000000

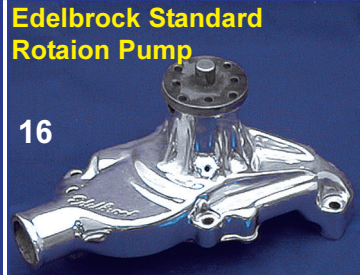
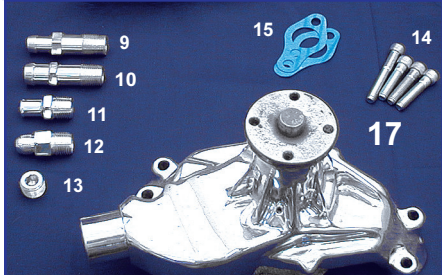

**Water Pump #16 Alt & Alt/PS ONLY**

**TIMING CHAIN COVERS** '73 & Earlier #1000037  
See Pg. 12  
SS Bolt Kit #0000040  
'74 & Later #1000036  
7" Pointer #1000038  
8" Pointer #1000039

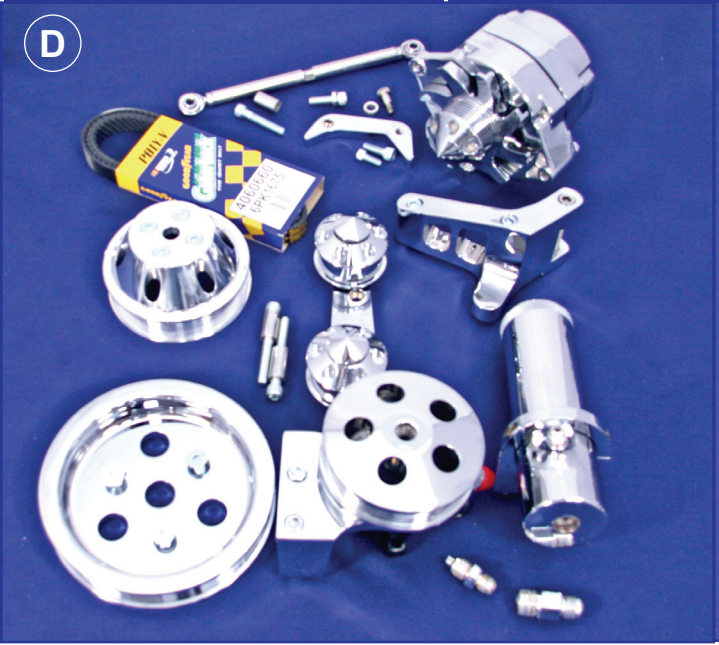



**Blower Vette/Camaro Brackets & Accessories - V-Belt**

**NOTE: THIS KIT WORKS GREAT IN 50'S AND LATER MODEL VEHICLES; TYPE I P/S WILL NOT CLEAR SOME FRAMES AND CROSS MEMBERS!**

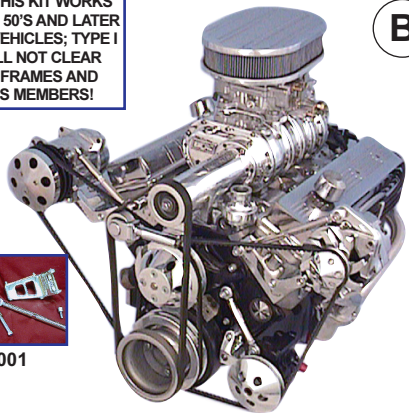

**B**



#10909001

**S/B W/STREET BLOWER DRIVE VETTE/CAMARO STYLE**  
Driver Side Alt / Pass Side Air using Type I P/S, with Lg GM Alt w/10 O'Clock Adapter and V-Belt Pulley Set



#10919028

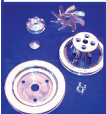

#10609050

**B&M BLOWER VETTE/CAMARO STYLE**  
Pass Side Alt (Only) using Lg GM Alt w/ 2 O'Clock Adapter 1-Groove V-Belt Pulley Set

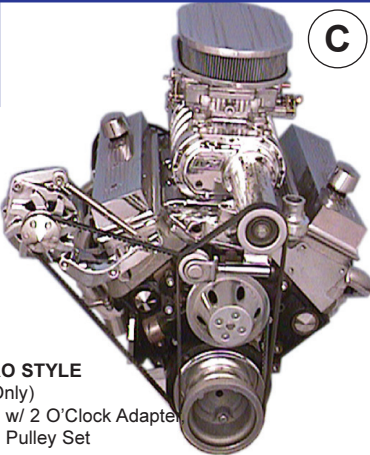

**C**



#10909001

#10609051

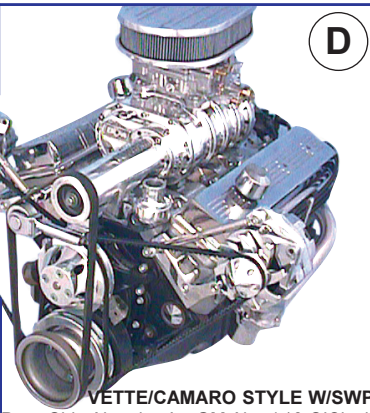
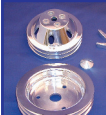

**D**

**VETTE/CAMARO STYLE W/SWP**  
Pass Side Air using Lg GM Alt w/ 10 O'Clock Adapter and 2 Groove V-Belt Pulley Set



#10919080

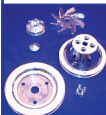

#10609050

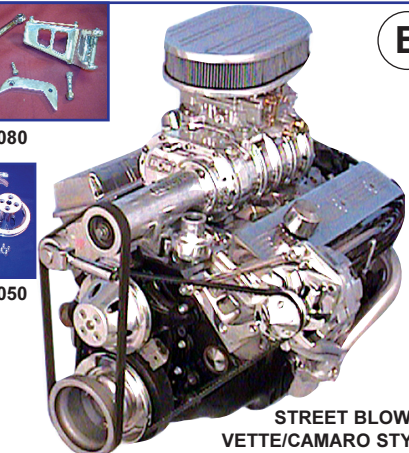

**E**

**STREET BLOWER VETTE/CAMARO STYLE**  
Driver Side Alt (Only) using Lg GM Alt w/ 10 O'Clock Adapter, w/ 1-Groove Crank V-Belt Pulley Set

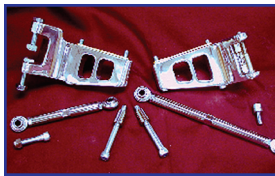

#10909001

#10609051

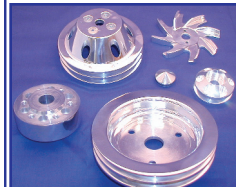

Blower Spacer Hub and Fan Optional

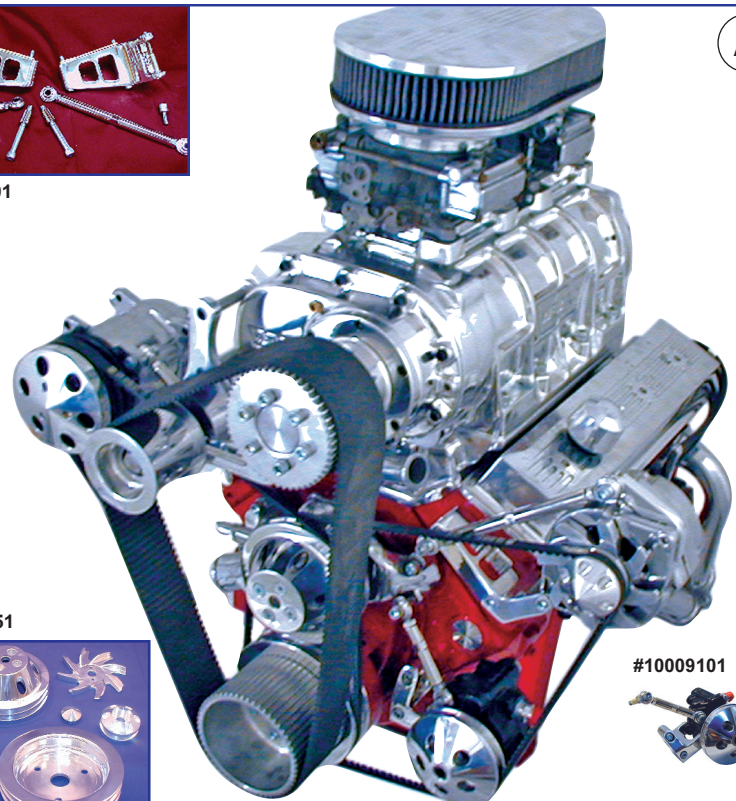

**A**

#10009101

**STREET BLOWER VETTE/CAMARO STYLE**  
Driver Side Alt / Pass Side Air using Type I P/S, w/Lg GM Alt w/ 10 O'Clock Adapter, and 2 Groove V-Belt Pulley Set



3-Bolt Hub Spacer

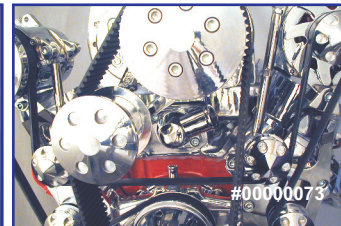

Blower 360/10 Degree Water Neck



6-Bolt Hub Spacer

**WORKS GREAT IN 50'S AND LATER MODEL VEHICLES!**

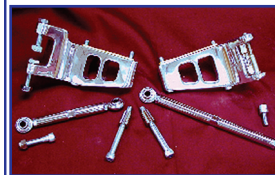

#10909001



Optional Blower Covers Available

**F**



#10609051

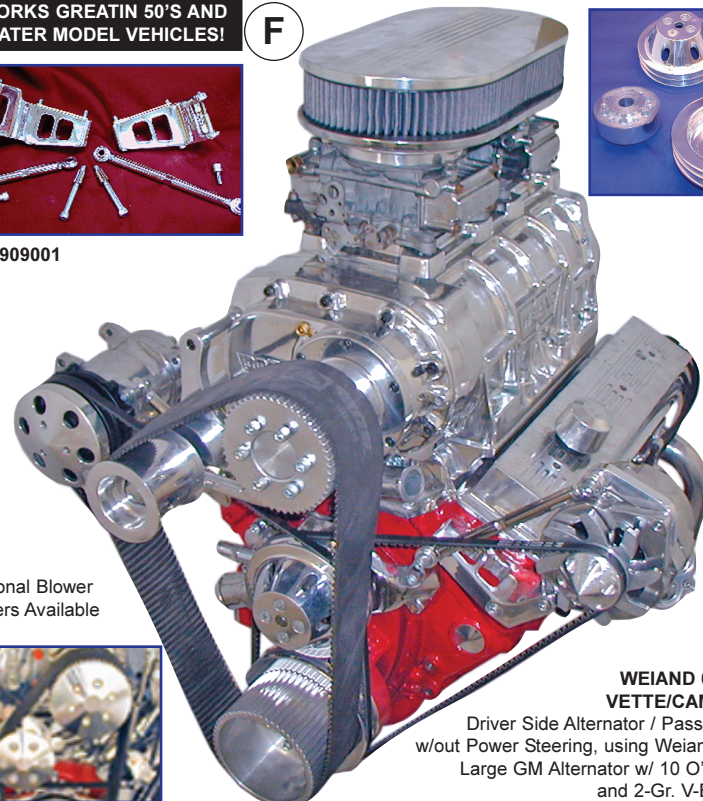

**WEIAND 671 BLOWER VETTE/CAMARO STYLE**  
Driver Side Alternator / Passenger Side Air w/out Power Steering, using Weiland 671 Blower, Large GM Alternator w/ 10 O'Clock Adapter and 2-Gr. V-Belt Pulley Set



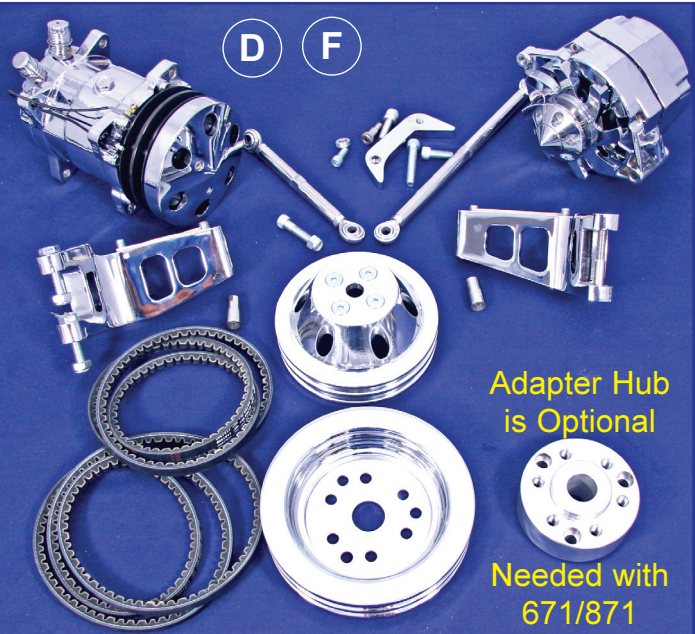
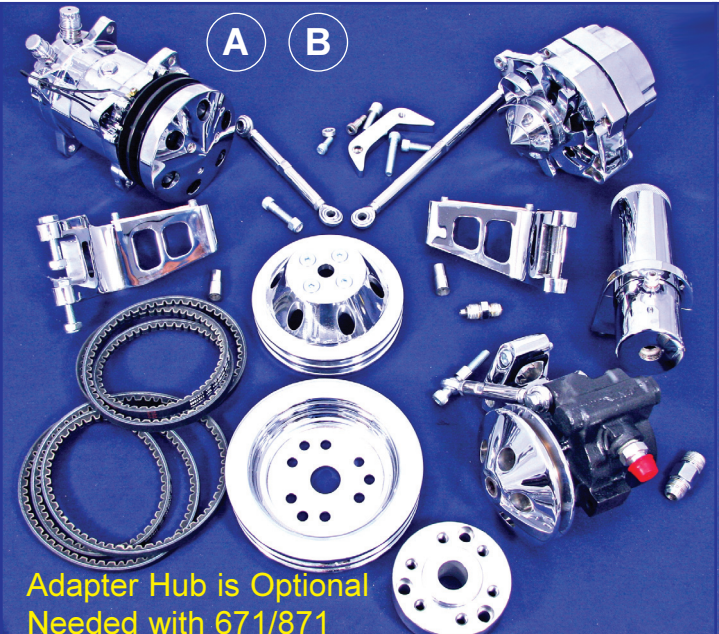

Adapter Hub is Optional  
Needed with 671/871

Adapter Hub is Optional

Needed with 671/871

**SWP ALT/AIR SERPENTINE BRACKET AND BAR KIT**

Complete Bracket Kits (as pictured) includes, Pulley Set, Idler Kit, PS Kit, GM 1 Wire 90 Amp Alternator, 508 Sanden Compressor, Alum. Alt Fan, 508 Front Cover, all Mounting Bolts, and Belt. *(Any item that you already have can be removed from the package and price reduced.)*

Part #	50's & Later Wide Style	Polished	Chrome	Part#	VETTE/CAMARO SWP V-BELT BRACKET KITS	Natural	Polished	Chrome
00000000	A,B. Alt & Air Kit with Type I P.S Pump.....	1578.95	1847.95	10909001	Driver Side Alt/Pass Side Air Kit V-Belt w/out 10 O'Clock Adapt .....	280.95	302.95	355.95
	A,B. Kit with Adapter.....	1663.95	1932.95	10969001	Driver Side Alt/Pass Side Air Kit V-Belt w/ 10 O'Clock Adapt .....	307.95	329.95	393.95
				10919080	Driver Side Alt (only) Kit (Inc. 10 O'Clock Adapter) .....	167.95	177.95	215.95
				10919028	Pass Side Alt (only) Kit (Inc. 2 O'Clock Adapter) .....	172.95	183.95	226.95
					<b>VETTE/CAM SWP V-BELT ALT &amp; AIR BRACKETS</b>			
	D,F. Alt & Air Kit (NO Power Steering) .....	1107.95	1316.95	10912001	Alternator (only) Driver Side Bracket .....	86.95	97.95	124.95
	D,F. Kit with Adapter.....	1192.95	1401.95	10902002	Alternator (only) Passenger Side Bracket .....	92.95	102.95	135.95
				10902004	Air (only) Driver Side Bracket - V-belt .....	92.95	102.95	135.95
				10902006	Air (only) Passenger Side Bracket - V-belt .....	86.95	97.95	124.95
	E. Driver Side Alt ONLY Alt ONLY .....	598.95	721.95	00000001	10 O'Clock Alternator Adapter Bracket for Driver Side .....	N/A	26.95	38.95
	C. Pass. Side Alt ONLY Alt Only .....	604.95	726.95	00000002	2 O'Clock Alternator Adapter Bracket for Passenger Side .....	N/A	26.95	38.95
				10009101	Type I Power Steering Setup .....	290.95	302.95	322.95
				00000441	16 mm to AN-6 Power Steering Fitting .....	N/A	17.49	20.49
				000009400	Aluminum P.S Reservoir with Bracket .....	N/A	135.95	172.95
				00000424	1/2" Pipe to AN-3 Fitting .....	N/A	17.49	20.49
				10600052	3-Bolt Blower Crank Hub Adapter - 1/2 pitch .....	N/A	84.95	N/A
				10600053	6-Bolt Blower Crank Hub Adapter - 1/2 pitch .....	N/A	84.95	N/A
				10600054	3-Bolt Blower Crank Hub Adapter - mm .....	N/A	84.95	N/A
				10600055	6-Bolt Blower Crank Hub Adapter - mm .....	N/A	84.95	N/A
				000000000	Blower Pulley Front Covers (Call for Details 479-394-5711) .....	N/A	113.95	167.95
				10609051	Blower 2- Groove Pulley Set (Crank, WP & Alt.) .....	N/A	221.95	275.95

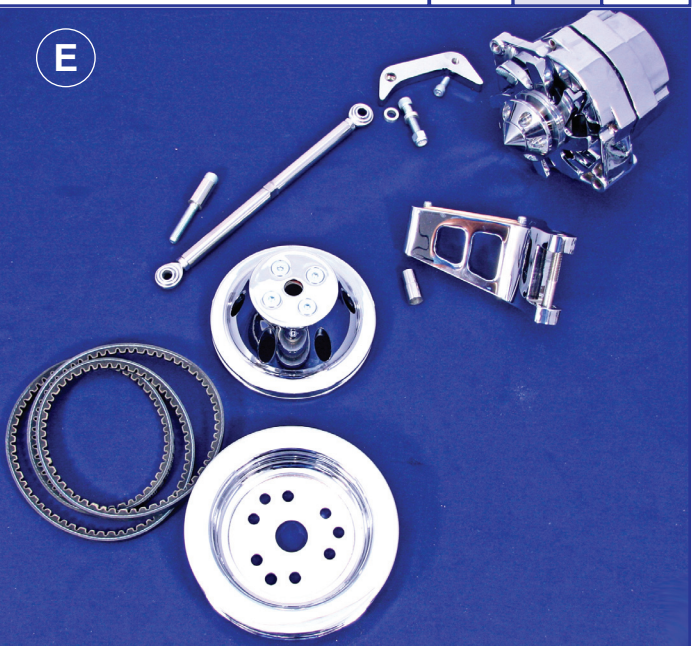



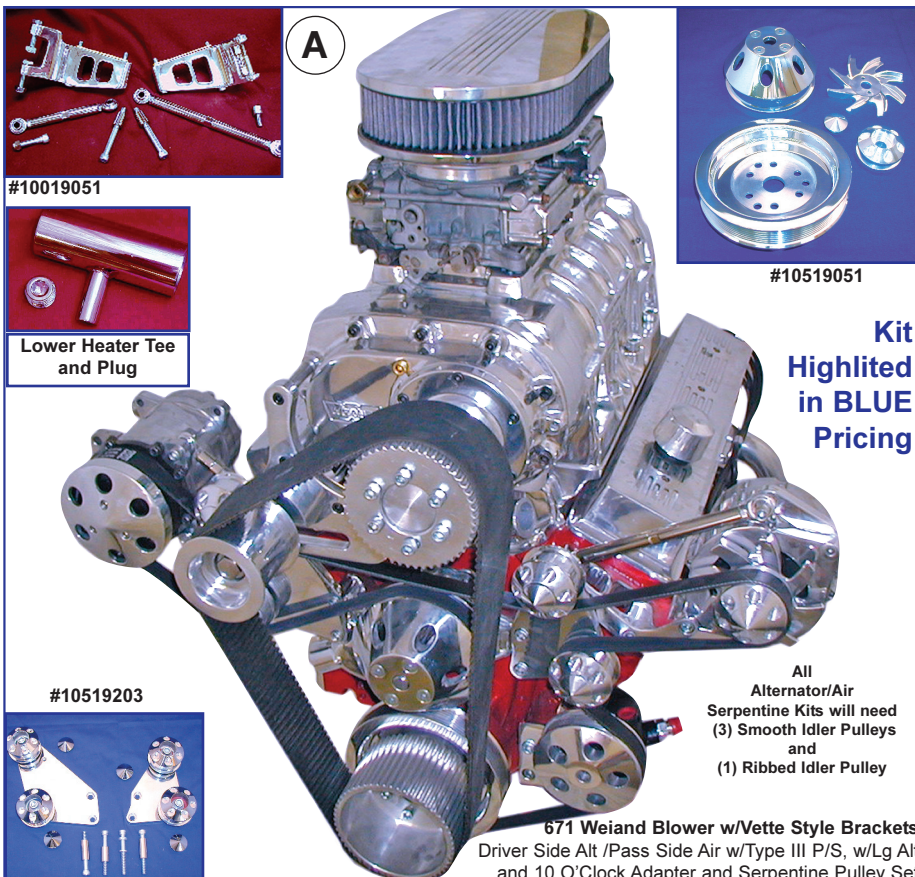

**A**

**B**

**C**

**D**

**E**

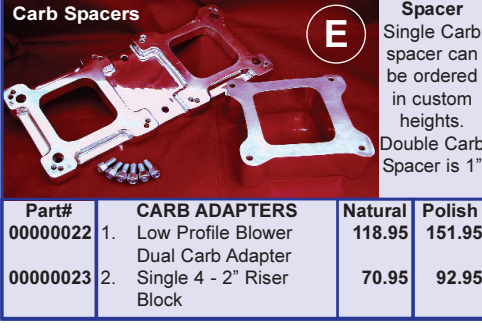
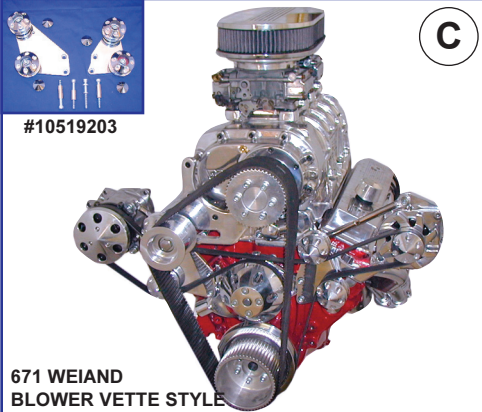
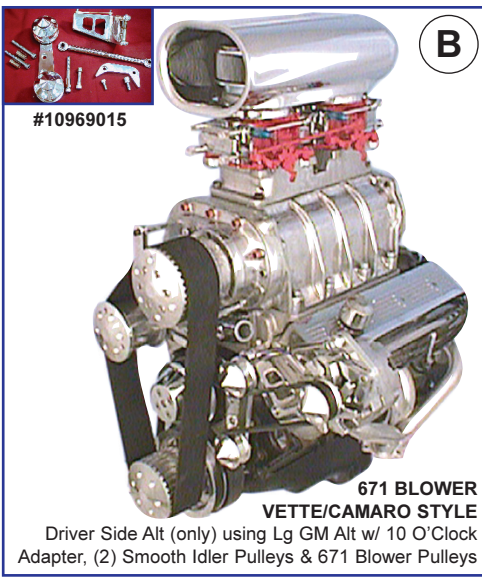

**Kit Highlighted in BLUE Pricing**

All Alternator/Air Serpentine Kits will need (3) Smooth Idler Pulleys and (1) Ribbed Idler Pulley

671 Weiand Blower w/Vette Style Brackets  
Driver Side Alt /Pass Side Air w/Type III P/S, w/Lg Alt and 10 O'Clock Adapter and Serpentine Pulley Set

671 WEIAND BLOWER VETTE STYLE  
Driver Side Alt/Pass Side Air w/o P/S, w/ Lg GM Alt 10 O'Clock Adapter and Serpentine Pulley Set

671 WEIAND BLOWER VETTE/CAMARO STYLE  
Driver Side Alternator / Passenger Side Air using Type III Power Steering, Lg GM Alternator w/ 10 O'Clock Adapter and Serpentine Pulley Set

Part#	VETTE/CAMARO SWP SERP & V-BELT BRACKET KITS Inc.: SS Adjuster Bar & Bolts.	Natural	Polished	Chrome
10909001	Driver Side Alt/Pass Side Air Kit V-Belt w/out 10 O'Clock Adapt . . . . .	280.95	302.95	355.95
10969001	Driver Side Alt/Pass Side Air Kit Serpentine w/out 10 O'Clock Adapt . . . . .	280.95	302.95	355.95
10919080	Driver Side Alt (only) Kit (Inc. 10 O'Clock Adapter) . . . . .	167.95	177.95	215.95
10919028	Pass Side Alt (only) Kit (Inc. 2 O'Clock Adapter) . . . . .	172.95	183.95	226.95
10969019	D/S Alt/Pass Air Kit (Inc. 2 Idler Bracket w/4 Idlers w/o 10 O'Clock adapt)	699.95	721.95	844.95
10969018	D/S Alt/Pass Air Kit (Inc. 2 Idler Bracket w/4 Idlers w/ 10 O'Clock adapt)	726.95	748.95	870.95
10969015	D/S Alt Only Kit - (Inc. Brackets, Idlers, 10 O'Clock & Bars) . . . . .	376.95	388.95	463.95
10019103	Type III Power Steering Kit . . . . .	280.95	302.95	322.95
<b>VETTE/CAM SWP/LWP V-BELT ALT &amp; AIR BRACKETS</b>				
10912001	Alternator (only) Driver Side Bracket . . . . .	86.95	97.95	124.95
10902002	Alternator (only) Passenger Side Bracket . . . . .	92.95	102.95	135.95
10902004	Air (only) Driver Side Bracket - V-belt . . . . .	92.95	102.95	135.95
10912006	Air (only) Passenger Side Bracket - Serpentine . . . . .	86.95	97.95	124.95
10902006	Air (only) Passenger Side Bracket - V-belt . . . . .	86.95	97.95	124.95
00000001	10 O'Clock Alternator Adapter Bracket for Driver Side . . . . .	N/A	26.95	38.95
00000002	2 O'Clock Alternator Adapter Bracket for Passenger Side . . . . .	N/A	26.95	38.95
<b>ADJUSTER BAR KIT &amp; ACCESSORIES</b>				
10905918	Alternator/Air Adjuster Bar Kit - V-Belt . . . . .	N/A	107.95	N/A
10965918	Alternator/Air Adjuster Bar Kit - Serpentine . . . . .	N/A	107.95	N/A
10965916	Alternator (only) Adjuster Bar Kit - Serpentine . . . . .	N/A	53.95	N/A
10905916	Alternator (only) Adjuster Bar Kit - V-Belt . . . . .	N/A	43.95	N/A
10965917	Air (only) Adjuster Bar Kit - Serpentine . . . . .	N/A	43.95	N/A
10905917	Air(only) Adjuster Bar Kit - V-Belt . . . . .	N/A	43.95	N/A
	***Polished SS Heim Ends (Add Per Bar) . . . . .	N/A	11.95	N/A
00000030	Smooth Idler Pulley . . . . .	N/A	81.95	92.95
00000029	Ribbed Idler Pulley . . . . .	N/A	81.95	92.95
10519203	Idler Bracket Alt/Air - 2 brackets, 4 idlers (For Blower) . . . . .	N/A	420.95	485.95
10519202	Drivers Side Dual Idler Bracket Alt Only w/ 2 idlers . . . . .	N/A	210.95	248.95
10119208	Drivers Side Dual Idler Bracket Alt Only, w/2 idlers (using P/S) . . . . .	N/A	210.95	248.95
10110403	Vette Short SB Aluminum Water Pump w/ 3/4" Pilot . . . . .	151.95	204.95	N/A
10619051	Blower Pulley Set Serpentine (Inc: Crank, W/P, Smooth Alt) . . . . .	N/A	275.95	339.95
10619052	Blower Pulley Set Serpentine (Inc: Crank, W/P, Ribbed, Alt) . . . . .	N/A	285.95	339.95
10600052	3-Bolt Blower Crank Hub Adapter - 1/2 pitch . . . . .	N/A	85.95	N/A
10600053	6-Bolt Blower Crank Hub Adapter - 1/2 pitch . . . . .	N/A	85.95	N/A
10600054	3-Bolt Blower Crank Hub Adapter - mm . . . . .	N/A	85.95	N/A
10600055	6-Bolt Blower Crank Hub Adapter - mm . . . . .	N/A	85.95	N/A
00000000	Blower Pulley Front Covers (Call for Details 479-394-5711)	N/A	113.95	167.95

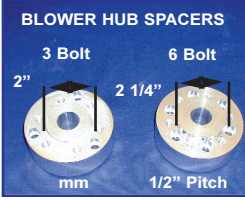

**BLOWER HUB SPACERS**  
It helps us to know what brand of blower you have. Weiand, B&M, Hampton, Holley, BDS and Mooneyham all have slightly different drives. We also need to know Crank bolt configuration, i.e. 3 bolt balancer, fluid dampner or 6 bolt steel hub.

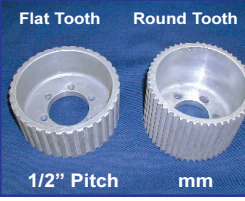

Part#	CARB ADAPTERS	Natural	Polish
00000022	1. Low Profile Blower Dual Carb Adapter	118.95	151.95
00000023	2. Single 4 - 2" Riser Block	70.95	92.95



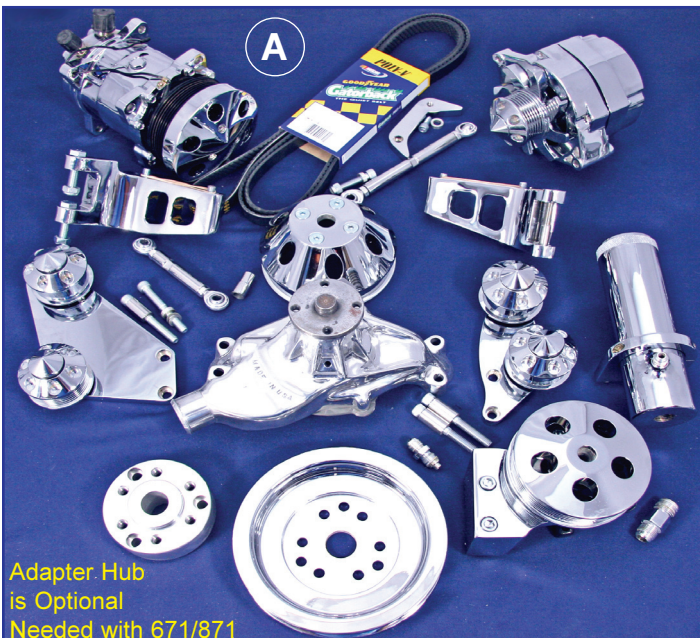

Adapter Hub  
is Optional  
Needed with 671/871

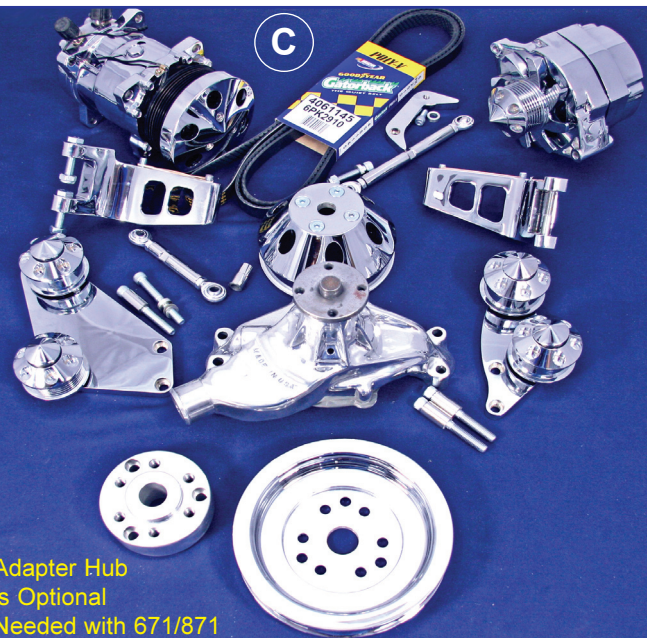

Adapter Hub  
is Optional  
Needed with 671/871

### SWP ALT/AIR SERPENTINE BRACKET AND BAR KIT

Complete Bracket Kits (as pictured) includes, Pulley Set, Water Pump, Idler Kit, PS Kit, GM 1 Wire 90 Amp Alternator, 508 Sanden Compressor, Alum. Alt Fan, 508 Front Cover, all Mounting Bolts, and Belt. **(Any item that you already have can be removed from the package and price reduced.)**

Part #	50's & Later Wide Style	Polished	Chrome	Part#	VETTE/CAMARO SWP SERPENTINE BRACKET KITS	Natural	Polished	Chrome
00000000	A. Alt & Air Kit with Type III P.S Pump	2279.95	2613.95	10969001	Driver Side Alt/Pass Side Air Kit Serpentine w/out 10 O'Clock Adapt	280.95	302.95	355.95
	A. Kit with Adapter	2362.95	2697.95	10919080	Driver Side Alt (only) Kit (Inc. 10 O'Clock Adapter)	167.95	177.95	215.95
				10919028	Pass Side Alt (only) Kit (Inc. 2 O'Clock Adapter)	172.95	183.95	226.95
				10969019	D/S Alt/Pass Air Kit (Inc. 2 Idler Bracket w/4 Idlers w/o 10 O'Clock adapt)	699.95	721.95	840.95
				10969018	D/S Alt/Pass Air Kit (Inc. 2 Idler Bracket w/4 Idlers w/ 10 O'Clock adapt)	726.95	748.95	877.95
	C. Alt & Air Kit (NO Power Steering)	17808.95	2081.95	10969015	D/S Alt Only Kit - (Inc. Brackets, Idlers, 10 O'Clock & Bars)	376.95	388.95	462.95
	C. Kit with Adapter	1892.95	2166.95	10019103	Type III Power Steering Kit	290.95	302.95	322.95
					VETTE/CAM SWP SERPENTINE ALT & AIR BRACKETS			
	Driver Side Alt & PS			10912001	Alternator (only) Driver Side Bracket	N/A	53.95	N/A
	D. Alt & PS	1407.95	1633.95	10902002	Alternator (only) Passenger Side Bracket	N/A	53.95	N/A
	D. Kit with Adapter	1491.95	1718.95	10912006	Air (only) Passenger Side Bracket - Serpentine	N/A	11.95	N/A
				00000001	10 O'Clock Alternator Adapter Bracket for Driver Side	N/A	26.95	38.95
	Driver Side Alt ONLY			00000002	2 O'Clock Alternator Adapter Bracket for Passenger Side	N/A	26.95	38.95
	B. Alt Only	935.33	1102.95	10519203	Idler Bracket Alt/Air - 2 brackets, 4 idlers (For Blower)	N/A	420.95	485.95
	B. Kit with Adapter	1020.95	1187.95	10519202	Drivers Side Dual Idler Bracket Alt Only w/ 2 idlers	N/A	210.95	248.95
				10119208	Drivers Side Dual Idler Bracket Alt Only, w/2 idlers (using P/S)	N/A	210.95	248.95
				10110403	Vette Short SB Aluminum Water Pump w/ 3/4" Pilot	151.95	204.95	N/A
				10619051	Blower Pulley Set Serpentine (Inc: Crank, W/P, Smooth Alt)	N/A	285.95	339.95
				10619052	Blower Pulley Set Serpentine (Inc: Crank, W/P, Ribbed, Alt)	N/A	285.95	339.95
				10600052	3-Bolt Blower Crank Hub Adapter - 1/2 pitch	N/A	84.95	N/A
				10600053	6-Bolt Blower Crank Hub Adapter - 1/2 pitch	N/A	84.95	N/A
				10600054	3-Bolt Blower Crank Hub Adapter - mm	N/A	84.95	N/A
				10600055	6-Bolt Blower Crank Hub Adapter - mm	N/A	84.95	N/A
				00000000	Blower Pulley Front Covers (Call for Details 479-394-5711)	N/A	113.95	167.95

When using this steel hub, you must have the hub adapter to the right with a 2" female register.

Adapter Hub  
is Optional  
Needed with  
671/871

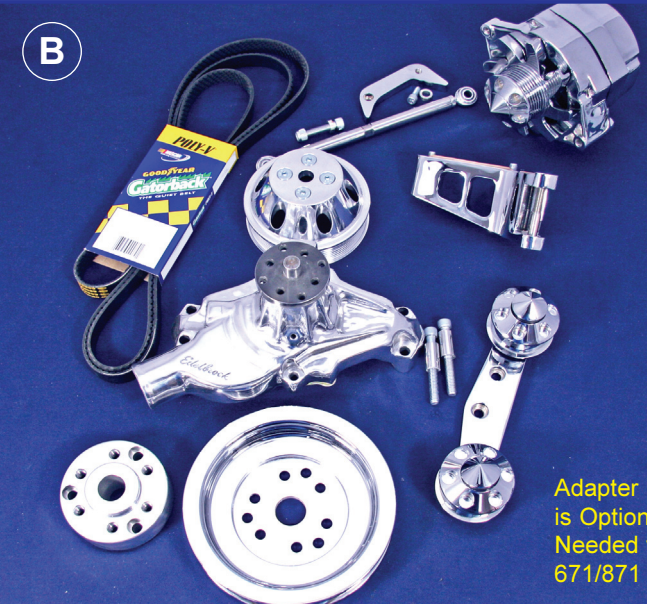
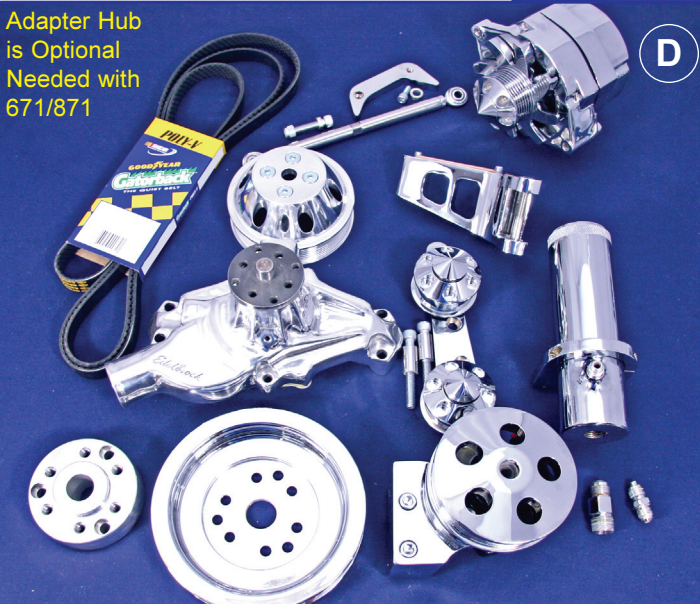

Adapter Hub  
is Optional  
Needed with  
671/871

Blower, Vette/Camaro Brackets & Acc. - Serpentine



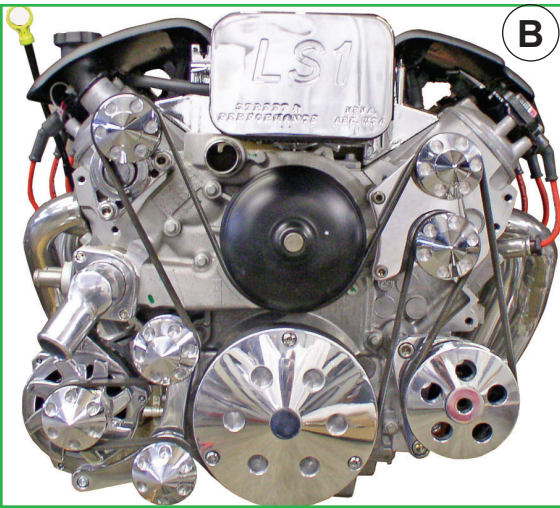

**B**

**LS-1 - LS-6 Street Rod**  
 Low Pass Side Alt, Low Driver Side P/S  
 Fits in all Street Rods and most narrow type chassis

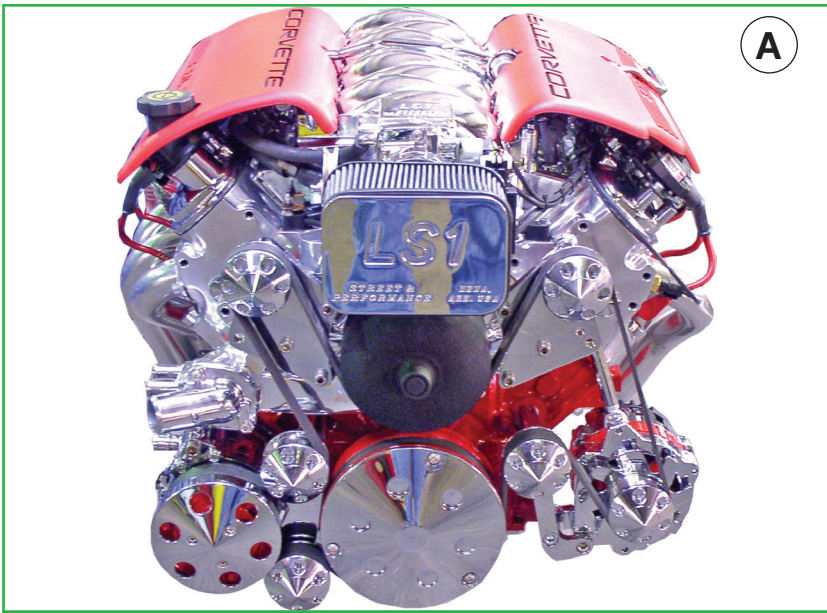

**A**

**LS-1 STREET ROD STYLE**  
 Street Rod Driver Side Alt/Pass Air w/o P/S, Small 10 O'Clock Alt,  
 (2) Driver Side Idlers and (2) Passenger Side Idlers .

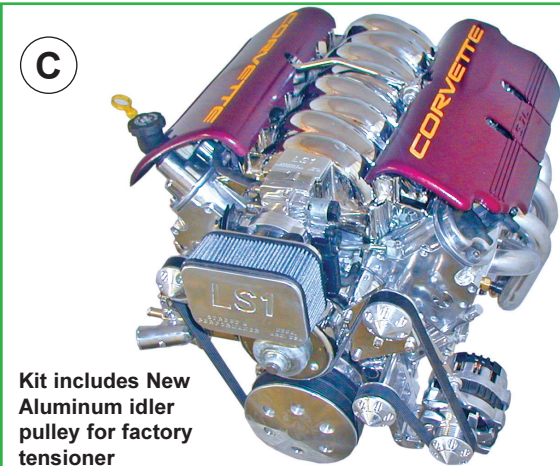

**C**

Kit includes New Aluminum idler pulley for factory tensioner

**LS1 (STREET ROD STYLE)**  
 Street Rod Driver Side Alternator (Only)  
 without Power Steering, using Small 10 O'Clock Alternator,  
 (1) Idler Driver Side, and Serpentine Pulley Set

**IROC/TA & GTO Balancers are 3/4" longer than Vette balancers.**  
**4.8, 5.3, 6.0 are 1 1/2" longer than Vette**



**97-03**

**D**

360/15 degree swivel \$99.95

360/45 degree swivel \$99.95

Straight \$78.95

O-ring and Thermostat included



**2004 up LS Water Necks**



**Straight Neck works BEST on early Vette Conversions**

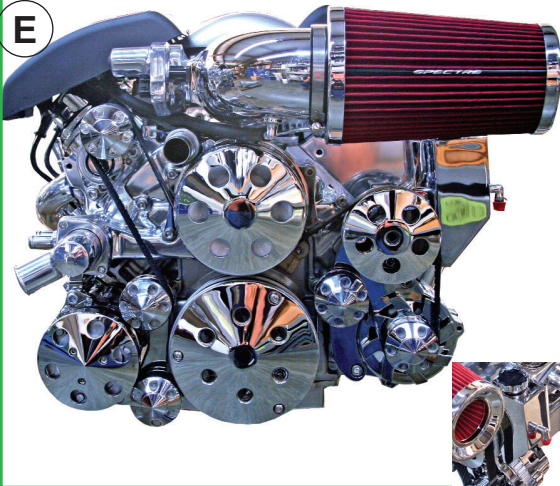

**E**

**LS1 / LS-2 / LS-7 VETTE (STREET ROD STYLE LOW)**  
 Driver Side Low Alt /Passenger Side Air w/ D.S P/S, using small GM 10'O Clock Alt, (1) Driver Side Idlers , (2) Passenger Side Idlers and high mount Passenger Side Tensioner, **Driver Power Steering Kit with Self Contained ALUMINUM RESERVOIR**

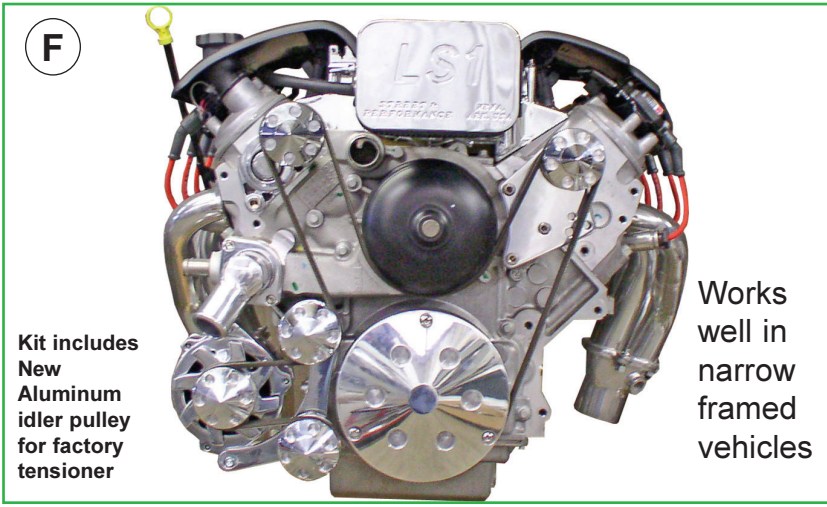

**F**

Kit includes New Aluminum idler pulley for factory tensioner

Works well in narrow framed vehicles

**LS1 (VETTE/CAMARO STYLE)**  
 Street Rod Low Passenger Side Alternator (Only)  
 Small 12 O'Clock Alternator, (2) Driver Side Idlers (3) Passenger Side Idlers  
 (Can be used with or without Power Steering)



**A Low Driver Alt. / Low Pass. AC**

**B Low Driver PS / Low Pass. Alt.**

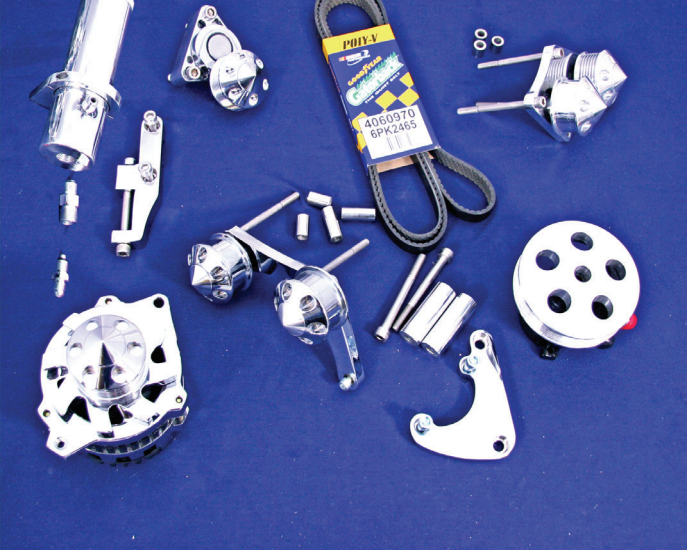

**Complete Bracket Kits (as pictured)**

includes, Pulley Set, Idler Kit, PS Kit, GM Internal 140 Amp Alternator, 508 Sanden Compressor, Alum. Alt Fan, 508 Front Cover, all Mounting Bolts, Gaskets and Belt. *(Any item that you already have can be removed from the package and price reduced.)*

Part #	Polished	Chrome
A. Alt, Air & NO PS Complete	1,656.95	1,877.95
B. Low Pass Side Alt, Low Driver Side PS Complete	1,510.95	1,722.95
C. Low Driver Side Alt ONLY Complete	840.95	958.95
E. Low D/Side Low P/Side AC with High MMT PS Complete	2,008.95	2,272.95
F. Low Pass. Side Alt ONLY Complete	989.95	1,113.95

**C Low Driver. Alt**



Part#	Necks with Thermostat	Polished	Chrome
	97-03 Straight Waterneck	78.95	N/A
	97-03 360 / 15 Waterneck	99.95	N/A
	97-03 360 / 45 Waterneck	99.95	N/A
	04-Up Straight Waterneck	78.95	N/A
	04-Up 360 / 15 Waterneck	99.95	N/A
	04-Up 360 / 45 Waterneck	99.95	N/A
	LS-1 IROC/TA Crank Cover	78.95	94.95
	LS-1 Vette Crank Cover	78.95	94.95
	LS-2 Vette Crank Cover	78.95	94.95
	LS-7 Vette Crank Cover	78.95	94.95
	97-03 Factory Thermostat	Natural 41.95	
	04-Up Factory Thermostat	41.95	

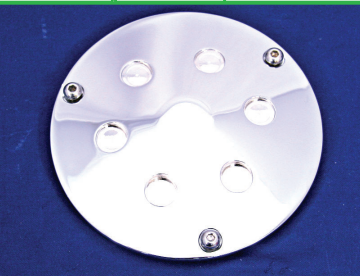

**LS Crank Covers Polished or Chrome**  
Use blue lock tight on bolts

**For Individual Parts Pricing See Page 101**

**E**

**F**



**Low Driver Alt  
Low Pass. AC  
Upper Pass PS**

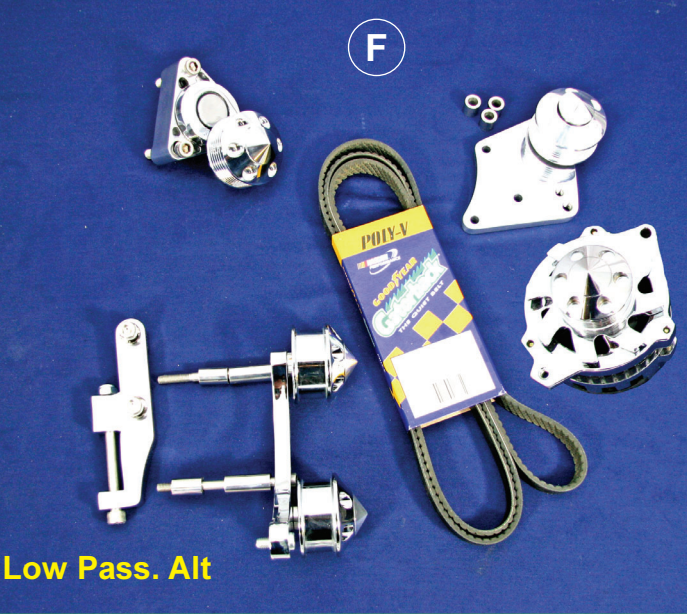

**Low Pass. Alt**





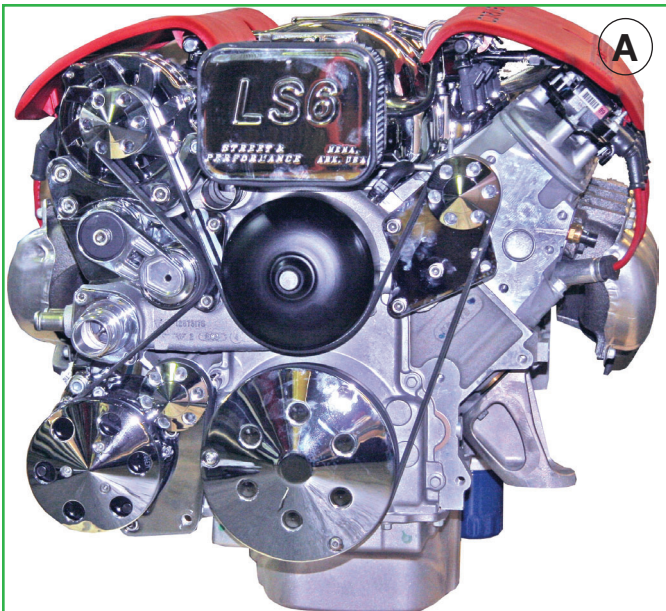

**A**

**Tight Upper Passenger Side Alternator and Low Passenger Side Air (Must use IROC Balancer)**

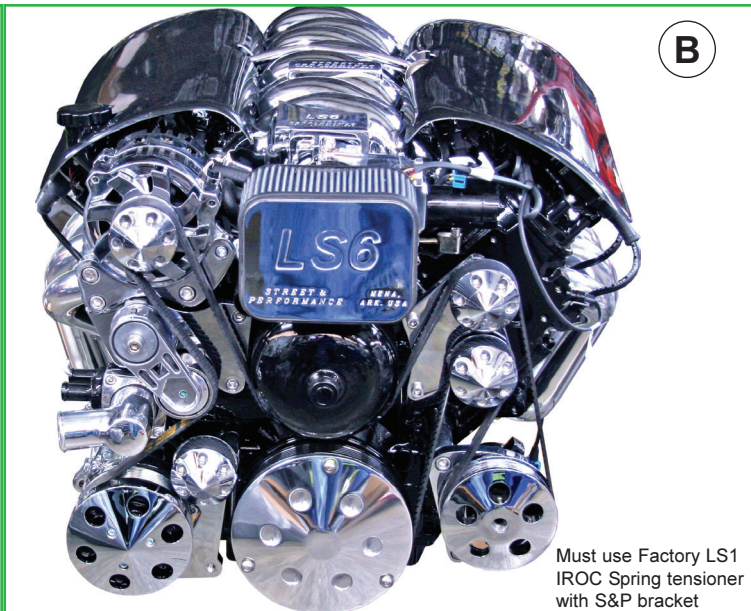

**B**

**Tight Upper Passenger Side Alternator, Low Passenger Side Air and Low Driver Side Power Steering (Must use IROC Balancer)**

Must use Factory LS1 IROC Spring tensioner with S&P bracket

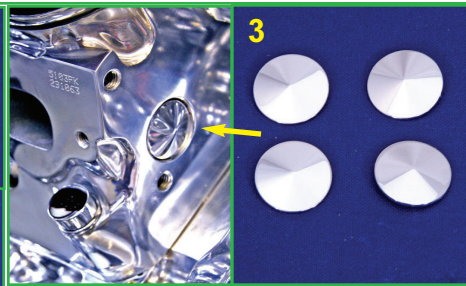
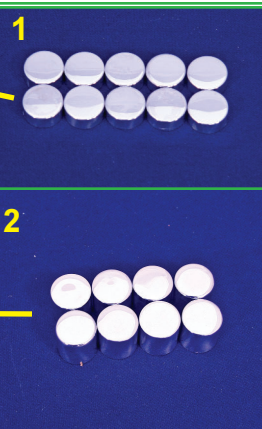

3. Alum Freeze Plug Covers

**1. Alum Head Bolt Covers    Pricing on**  
**2. Alum Cross Bolt Covers    Pg 83**  
**3. Alum Freeze Plug Covers    Available in Polished or Chrome**



**D**

**Tight Upper Passenger Side Alternator (Must use IROC Balancer)**

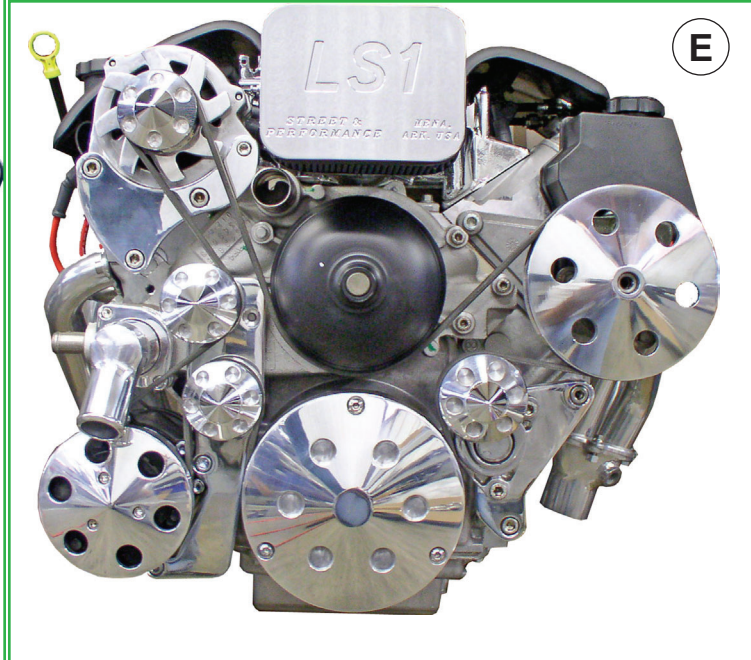

**E**

**Upper Pass. Side Alt. Low Pass. Side Air. Using factory IROC P.S Pump.**



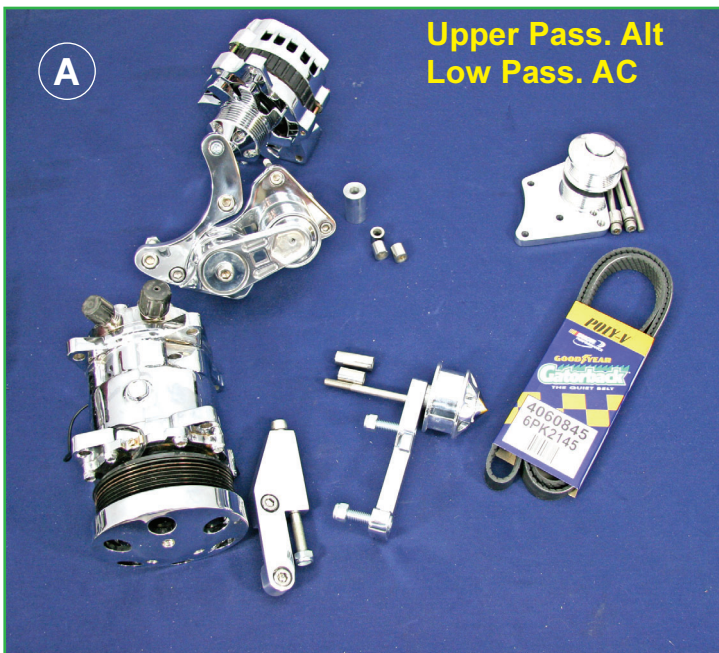

**Upper Pass. Alt  
Low Pass. AC**

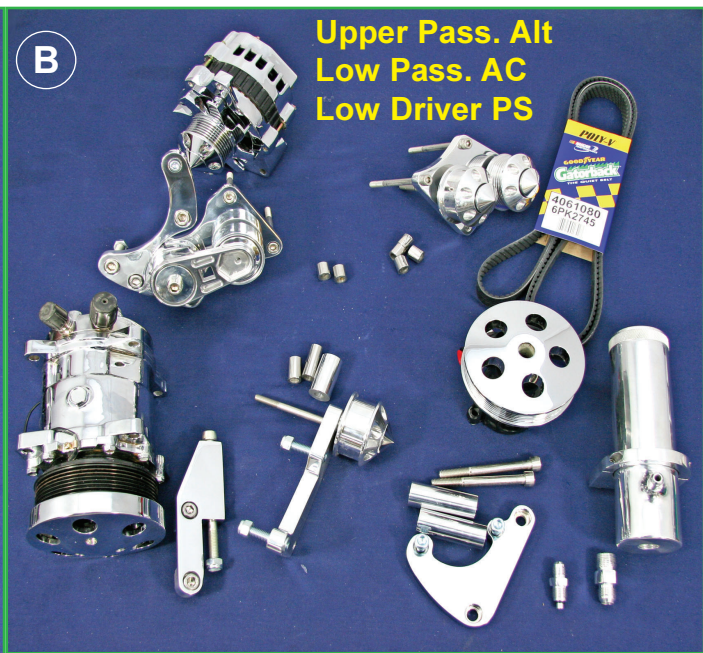

**Upper Pass. Alt  
Low Pass. AC  
Low Driver PS**

**Complete Kits (as pictured)**  
Includes, Brackets, Idler's, Goodyear tensioner, PS Kit, Small GM 140 Amp 2 O'clock Alternator, Alum. Alt Fan & Pulley, 508 Sanden Compressor, 508 Front Cover, all Mounting Hardware, and Belt. **(Any item that you already have can be removed from the package and price reduced.)**

Part #		Polished	Chrome
A.	Upper P/Side Alt Low P/Side AC Complete	1,613.95	1,872.95
B.	Upper P/Side Alt Low P/Side AC & Low D/Side PS Complete	2,079.95	2,369.95
B.	Same as (B) with Aluminum PS Self Contained RESERVOIR	2,245.95	2,554.95
D.	Upper P/Side Alt ONLY Complete	994.95	1,123.95
E.	Upper P/Side Alt Low P/Side AC using Factory IROC/TA PS	1,808.95	2,033.95

**Alum Bracket & Pulley for Goodyear tensioner. Supplied with Kits**

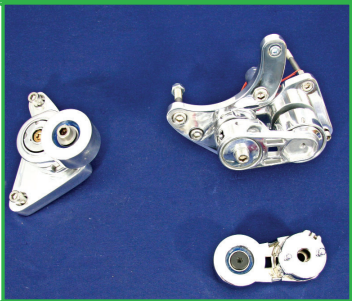

Part#		Polished	Chrome
	IROC/TA Alum. Factory replacement PS Pulley	105.95	139.95
	Tensioner with Alum Pulley	172.95	204.95
	Alum Head Bolt Covers	82.95	93.95
	Alum Cross Bolt Covers	41.95	51.95
	Alum Freeze Plug Covers	35.95	45.95

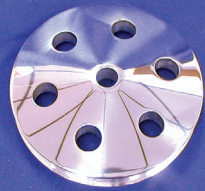

On 99-Up Low Pass. AC kits, The (F) ear must be cut off. S&P can cut the ear off of your compressor for block clearance



**These kits must change the Balancer on Vette engines to a IROC/TA Balancer. See pg. 105**

**98-02 Alum. Factory Replacement PS Pulley Polished or Chrome**

**For Individual Parts Pricing See Page 101**



**Upper Pass. Alt ONLY**

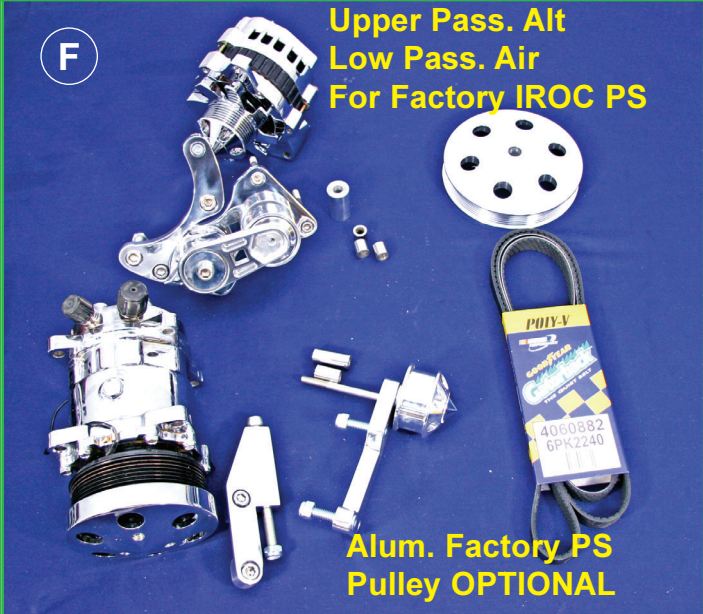

**Upper Pass. Alt  
Low Pass. Air  
For Factory IROC PS**

**Alum. Factory PS Pulley OPTIONAL**





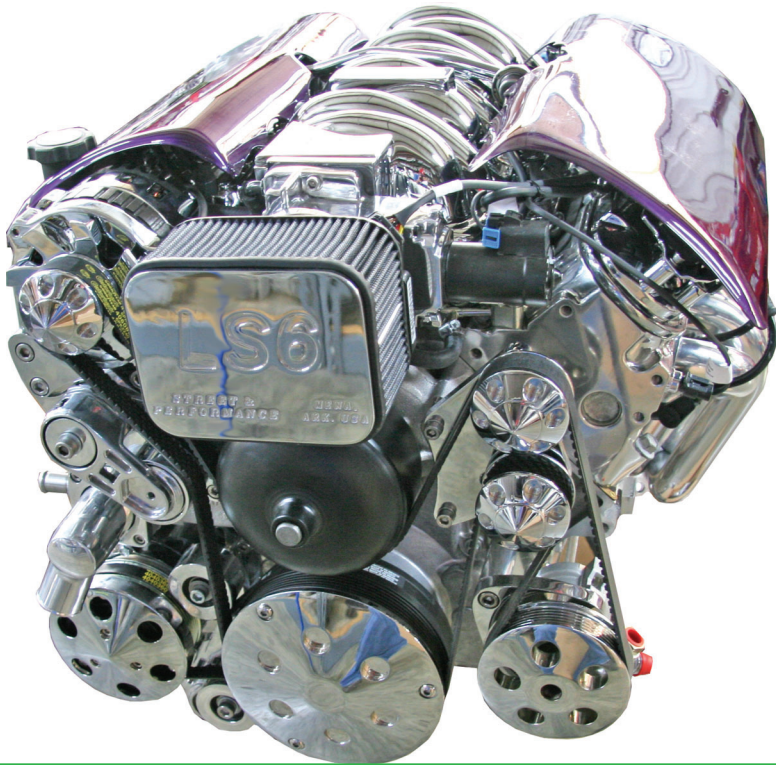

**TIGHT TUCK STREET ROD**

Alternator, Power Steering with Move Back AC. Must use IRCO/TA or GTO balancer. This kit is needed for higher horse power engines. On Vette engines balancer must be changed. 05-06 GTO LS-2 throttle body must be turned 180 degrees

Part #	Tight Tuck with move back AC	Natural	Polished	Chrome
	Comes complete with CS-130 Alternator (140 AMP), AC compressor with the (F) ear removed, Power Steering Pump Assembly, PS Reservoir, Idler Brackets and Pulleys, Fittings, Goodyear Gatorback Belt, Alternator Tensioner and AC Tensioner Kit with Self Contained PS Reservoir			
		N/A	2,182.95	2,472.95
		N/A	2,349.95	2,657.95

**Low AC Stand Alone Move Back Kit**

Compressor & Front Cover Optional.

Kit includes belt, tensioner and hardware.

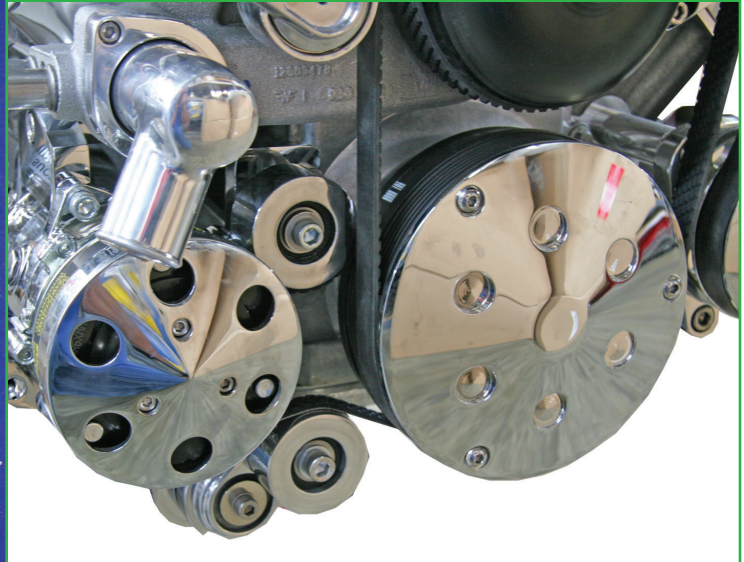
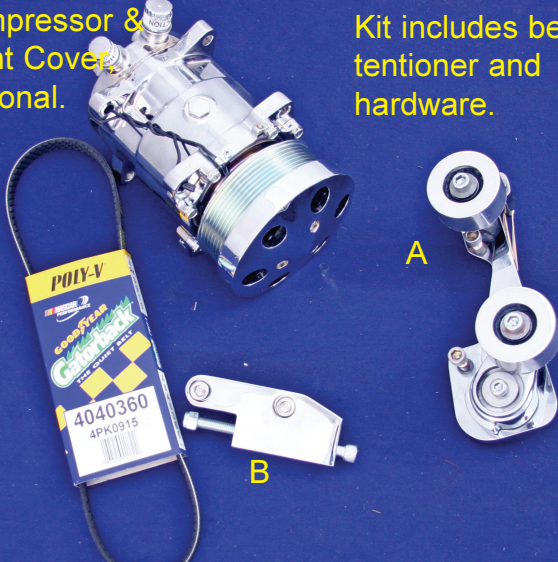

Part #	Low AC Stand Alone Move Back Kit	Natural	Polished	Chrome	For use when adding Low AC on passenger side with IROC/TA & GTO balancers. Kit also available for use on 4.8, 5.3 & 6.0 engines. This kit works great for blower and other high Horse Power engines. (AC belt runs on rear groove alone.)
	Complete Kit AS PICTURED. . . . .	N/A	793.95	910.95	
	Kit w/o Compressor/Front Cover. . .	N/A	460.95	527.95	
	A. Tentioner, Pulleys and Bracket. . .	N/A	342.95	394.95	
	B. AC mount only Bracket. . . . .	N/A	78.95	94.95	
4040360	Goodyear Belt. . . . .	39.95			





**Smooth Paintable Top Covers**  
**LS-1, LS-2, LS-3, LS-6, LS-7 GTO**  
**\$259.95 Per Set.**

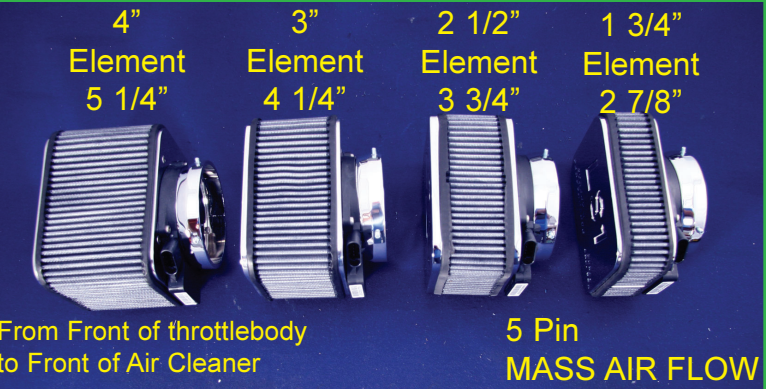
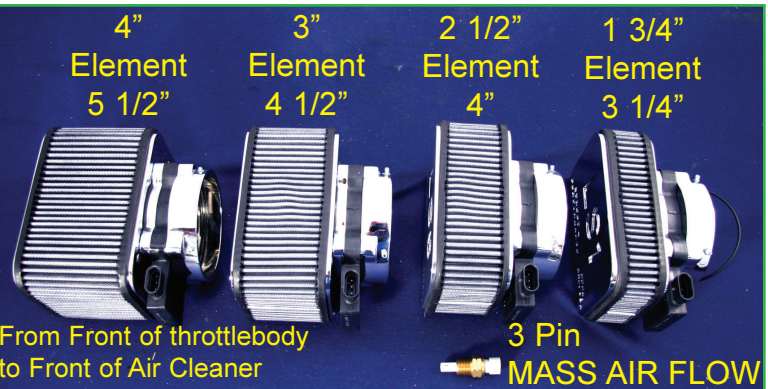

We clean and recondition injectors and we can add performance screens and will match flow your injectors, . . . . . \$ 144.95

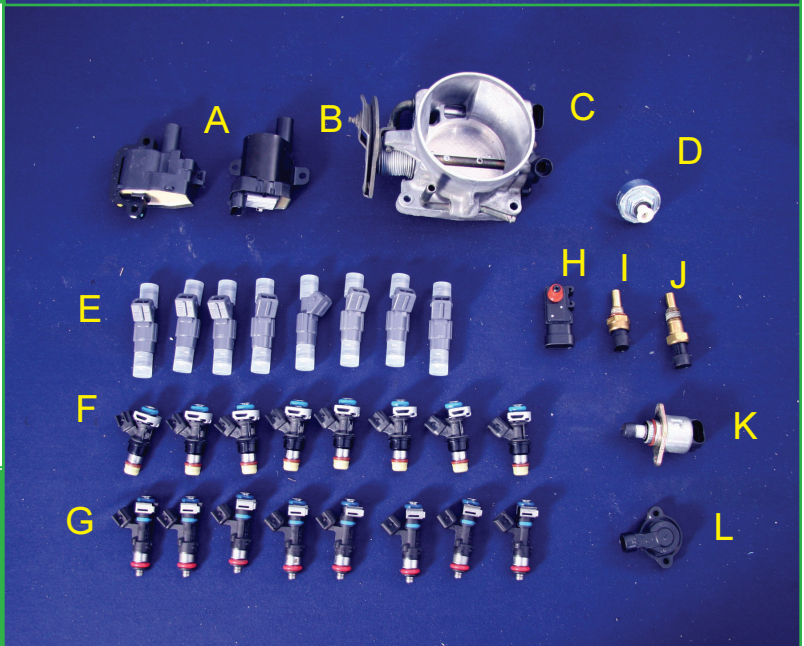

**LS1 ENGINE KIT INSTALLATION GUIDE**

LS1 Design and Development ■ Installation Notes ■ Engine Controls ■ Technical Information ■ Specifications

**RACING**

CONTENTS

Introduction	2
Design Features	3
Installation Notes	5
Cooling System	6
Fuel System	7
Lubrication System	8
Accessories	9
Electrical System	10
Engine Controls	11
Throttlebody	12
Specifications	13
Diagnostic Trouble Codes	19
PIB File Data	20
Engine Control Schematics	25

© General Motors Corp. All rights reserved. P/N 88959384 Revised 11/03

**GM's LS-1 Engine Kit Installation Guide**  
**88959384**  
**\$51.95**

A. 97 up Vette/Camaro/TA Ignition Coil . . .	40.95
B. 99 up 4.8, 5.3 and 6.0 Ignition Coil . . .	40.95
C. 98-02 Camaro/TA 04 GTO Throttlebody	409.95
D. 97-04 Knock Sensor, Vette, IROC, GTO	48.95
E. 97-04 Injectors, Vette, IROC, GTO (set) . .	466.95
F. 99-up 4.8, 5.3, 6.0 Injectors (set) . . . . .	466.95
G. 05-up LS-2 Vette, GTO Injectors. (set) .	466.95
H. GEN III MAP Sensor. . . . .	
I. 97-98 LS1 Coolant Temp Sensor 2 prong	14.95
J. 99-up GEN III Coolant Sensor 3 prong	14.95
K. 97-04 LS Idle Speed Motor. . . . .	113.95
L. 98-04 LS Throttle Position Sensor. . . . .	57.95







**(A)**

New Type IV Power Steering kit for Art Morrison G body and front mounted rack and pinion.

**97-04**

**LS-6 ENGINE (VETTE/STYLE)**

Drivers Side Alt Bracket, Pass Side Air Bracket, Low Drivers Side Power Steering Kit (4) Idlers Pulley's and (2) Brackets



**(B)**

**LS-2  
LS-7**

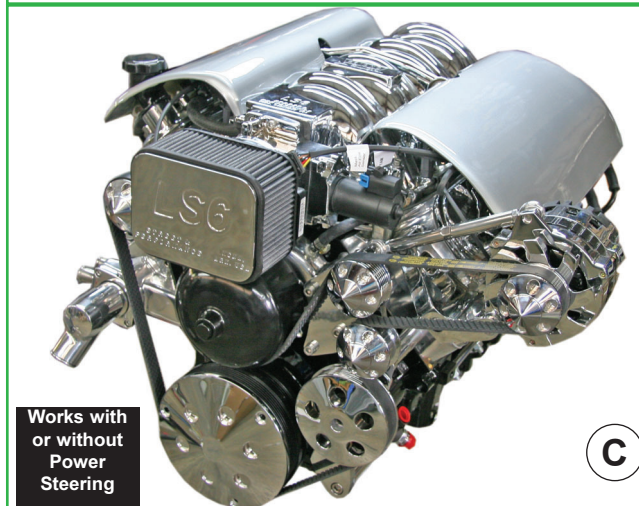

**(C)**

Works with or without Power Steering

**WIDE STYLE**

Driver side Alt, Driver side P/S low, works well in all Corvette's and 50's & later vehicles

Kits can be purchased without PS



**FEATURES**

Scan Collects Valuable Data from Vehicles On-Board Computer Supports multiple trouble code requests, generic codes, pending codes, enhanced codes On-screen definitions of OBD I trouble codes, OBD II generic and OBD II manufacturer specific codes

**FREE INTERNET UPDATES**

Complete Kit with Case (GM, Ford, Mopar) \$621.95

**Trouble Shooting Tools**



**\$20.95 per set**

**Noid Light Set**



**Infra Red Heat Gun \$93.95 with Case**



**D  
V  
D**

**LS2 and later Drive By Wire Tech DVD. Full of NEED TO KNOW Information**





Specify IROC/TA, Vette, Truck

**Complete Kits (as pictured)**  
Includes, Brackets, Idler's, PS Kit, Small GM 140 Amp Alternator, Alum. Alt Fan & Pulley, 508 Sanden Compressor, 508 Front Cover, all Mounting Hardware, and Belt. (Any item that you already have can be removed from the package and price reduced.)

Part #		Polished	Chrome
A.	LS1/LS6 Vette Alt, Air & PS Complete Without Power Steering	1,879.95	2,144.95
A.	LS2 Vette Alt, Air & PS Complete Without Power Steering	1,409.95	1,609.95
A.	LS1 IROC/TA Alt, Air & PS Complete Without Power Steering	1,879.95	2,144.95
A.	4.8 5.3 6.0 Alt, Air & PS Complete Without Power Steering	1,466.95	1,609.95
C.	LS1/LS6/LS2/LS7 Alt & PS ONLY Complete	1,901.95	2,166.95
C.	IROC/TA Alt & PS ONLY Complete	1,431.95	1,631.95
C.	4.8 5.3 6.0 Alt & PS ONLY Complete	955.95	1,105.95
C.	IROC/TA Alt & PS ONLY Complete	955.95	1,105.95
C.	4.8 5.3 6.0 Alt & PS ONLY Complete	965.95	1,116.95

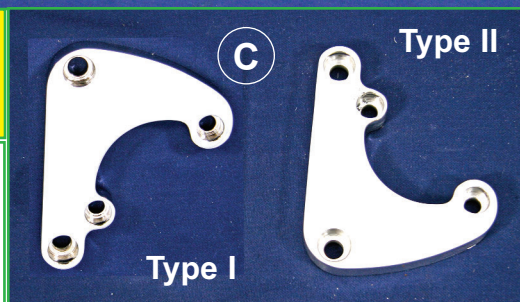

**Power Steering Brackets**  
Type I for Street Rods & Early Veh.  
Type II for All G Bodies and Vettes

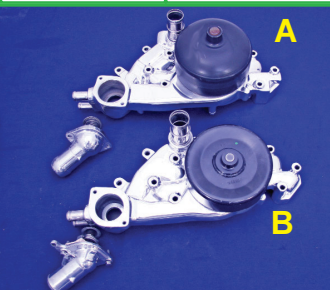

**LS Water Pumps**  
A. 97-03 LS1/LS6  
04-Up GTO & Vette  
B. 05-Up LS2/LS7  
Natural .....\$300.95  
Polished ADD.....\$300.95  
Comes with Thermostat & Waterneck  
**Specify Year**

**CS130AD**  
Pol. Chrome  
IROC/TA Alt w/o Pulley.....\$451.95 \$508.95  
IROC/TA Alt w/ Alum. Pulley...\$497.95 \$565.95  
CS130AD Pigtail .....\$26.95  
CS130AD Alum Alt Pulley..... \$48.95 \$59.95  
We can Polish or Chrome YOUR Alternator

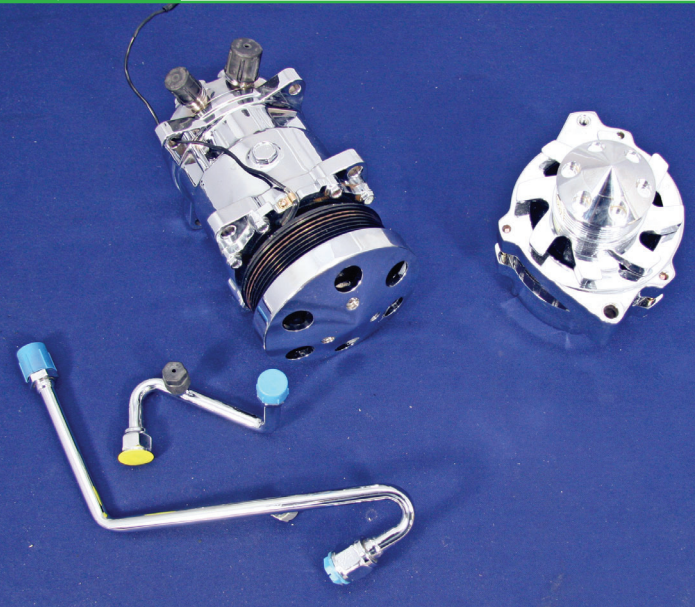

A. CS 130 & 144 For Gauge #12102921.....\$26.95  
B. CS 130 & 144 For Light #12083462.....\$26.95  
C. 10 SI Conversion from External to Internal Regulator Alternator #37796.....\$13.95

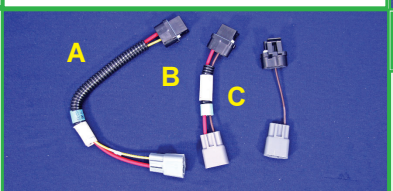

**Adapter Plug**  
Adapt Old Large Alt. Plug to CS 130 & CS 144 Plug using OEM Connectors

**LS-1 Alternator & Air Accessories**  
LS-1 need to use a 140 amp Alternator

Part #	Alt Complete w/ Billet Fan & Pulley	Natural	Polished	Chrome
00000000	12 O'clock CS130 -140 Amp with core	302.95	355.95	398.95
00000000	10 O'clock CS130 -140 Amp with core	302.95	355.95	398.95
00000000	2 O'clock CS130 -140 Amp with core	302.95	355.95	398.95
00000000	508 Air Compressor - 134 Serp.	226.95	280.95	334.95
00000000	508 Air Compressor - R12 Serp.	226.95	280.95	334.95
00000000	508 Type III Front Cover	N/A	53.95	65.95
00000000	Aluminum AC Hard Line Kit 134	43.95	65.95	97.95
00000000	Aluminum AC Hard Line Kit R-12	43.95	65.95	97.95



**LS Engine & Accessories**

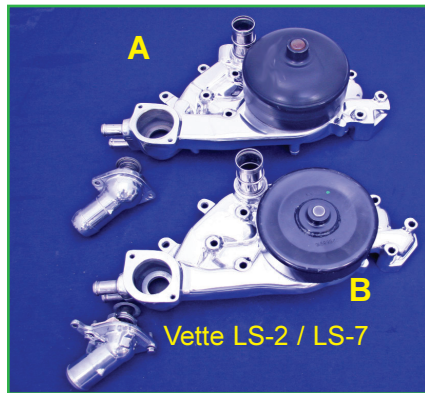

**LS Water Pumps**  
**A. 97-03 LS1/LS6**  
**04-Up GTO & Vette**  
**B. 05-Up LS2/LS7**  
 Natural .....\$295.95  
 Polished ADD.....\$295.95  
 Comes with Thermostat & Waterneck  
**Specify Year, 4.8-5.3-5.7-6.0 Truck or Camaro or Vette balancer.**

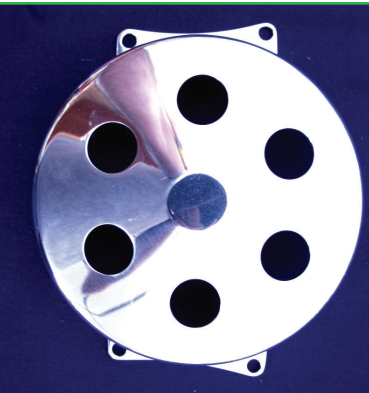

LS Waterpump Pulley Covers  
 Need to know Waterpump used, (A) or (B) and style of brackets used on your application.

Waterpump (A) is used on LS-1Vette/IROC-TA, LS-6, GTO '04-'06 can be used with Vette or Camaro style balancer. Waterpump (B) can be used on any GENIII Engine when using a Vette Balancer.

Part #	(A) Style Waterpump Pulley Cover LS-2 LS-7 .....	Polished	Chrome
	(B) Style Waterpump Pulley Cover LS-1 LS-6 04 GTO.....	124.95	155.95
		140.95	175.95

**Adjustable Idler Pulley Tensioner Brackets for Higher Horsepower Applications**

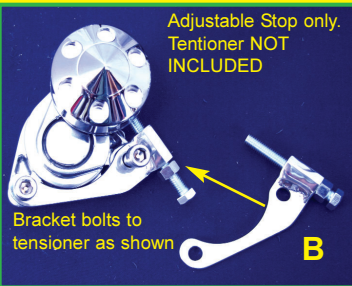
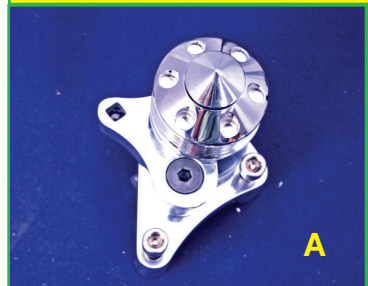

Replaceable tensioner upper passenger side for extra tension. With all mounting hardware

Factory Tensioner adjustable stop. Limits tensioner movement

Part #	Polished	Chrome
A. Upper passenger side tentioner	\$165.95	\$196.95
B. Factory tentioner adjustable stop	\$46.95	\$56.95

**58-64 Passenger Car Crossmember Kit for T-56, 4L60E & 4L65E**



**GEN III Sensor Adapters Coolant / Oil**

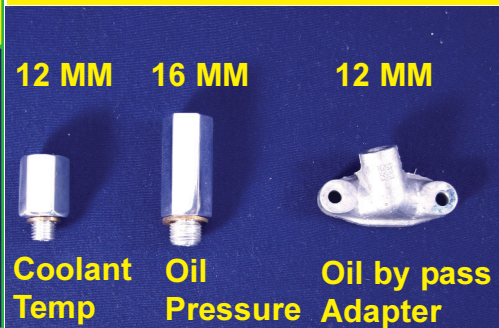

**Coolant \$18.49**  
 12mm x 1/8 NPT  
 12mm x 1/4 NPT  
 12mm x 3/8 NPT  
 12mm x 1/2 NPT  
**Oil \$18.49**  
 16mm x 1/8 NPT  
 16mm x 1/4 NPT  
 16mm x 3/8 NPT  
 16mm x 1/2 NPT  
 By Pass \$34.95

**67-69 Camaro Crossmember Kit**

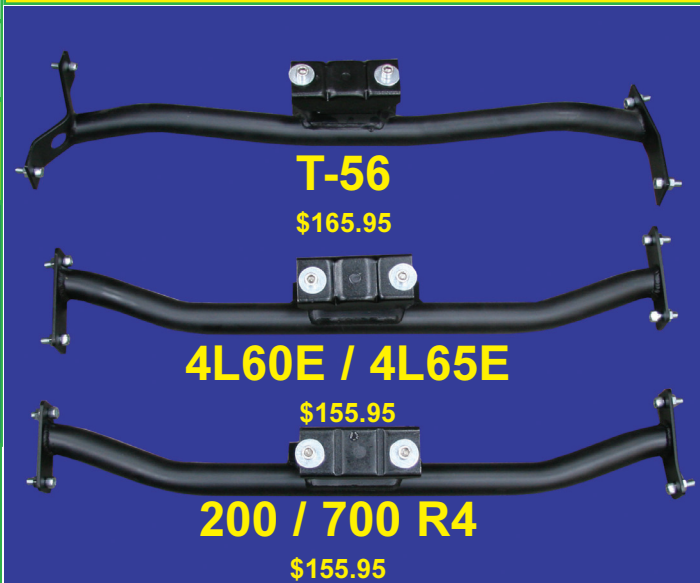

**Firewall Clutch Cylinder Mounting Brackets**

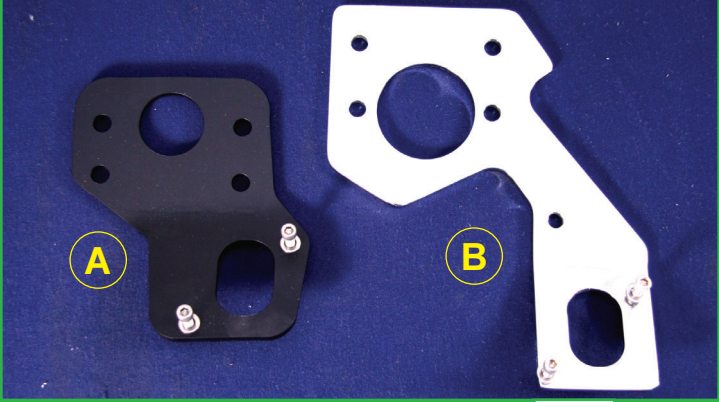

Part #	Black	Chrome
A. '67 Up GM Clutch Cylinder Bracket	\$78.95	\$99.95
B. '58-'64 GM Clutch Cylinder Bracket	\$93.95	\$120.95

**T-56 Shifter Handle Relocator**

Moves Shifter 1" to 4.100" Forward.  
 See web for available applications  
**\$347.95**



Rear Block Off Plugs  
 Plain \$6.95 each  
 Chrome \$16.95 Each



Front Crossover Tube  
 Plain \$44.95  
 Chrome \$59.95

**S&P Replacement  
 Air Filter Elements**

1 3/4" Element . . . \$22.95  
 2 1/2" Element . . . \$22.95  
 3" Element . . . . \$22.95  
 4" Element . . . . . \$22.95

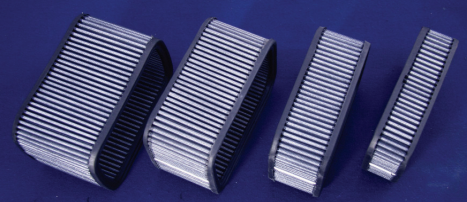

**GEN III Steam Line & Rear Block off Kit**  
 For use with S&P Aluminum intake,  
 Factory LS-6 intakes and Blower Kits

**3 Pin MAF  
 Air Filter**



RU 3130  
 7" Long

**5 Pin MAF  
 Air Filters**

RU 2520  
 5" Long

RU 2590  
 7" Long

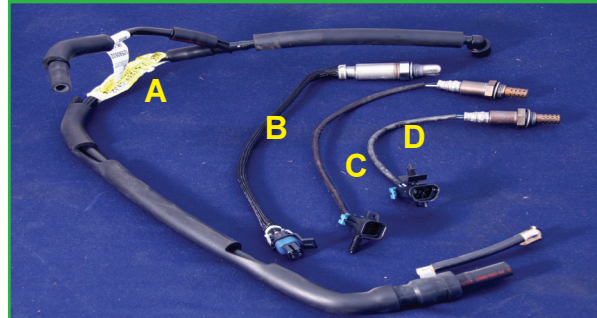
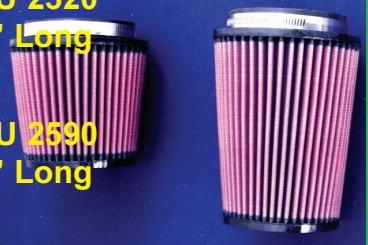

**GEN III PCV and Oxygen Sensor**  
 A. '97-'02 PCV Hose (Vette/IROC) \$91.95  
 B. LS Square male O2 Sensor \$78.95  
 C. LS Square Female O2 Sensor \$78.95  
 D. LS D Shape Female O2 Sensor \$88.95

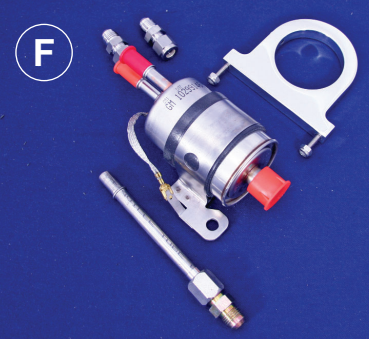

**Single Line Filter  
 Regulator**

Uses 99-Up Vette fuel filter, allows the use of one line to engine. Filter will return excess fuel to tank. \$181.95  
 Bracket Optional. Pol. \$37.95  
 Chrome \$47.95

**GEN III Engine to Tank Stainless Single Fuel Line Kit.**



'64 -'72 Chevelle Single Fuel Filter/Regulator Line Kit  
 Stainless Steel Complete from tank to fuel rail under the cover. Other Custom applications also Available.  
**Without Filter \$517.95. Filter ADD \$181.95**

**GEN III Engine to Tank Stainless Single Fuel Line Kit.**



'67-'69 Camaro Single Fuel Filter/Regulator Line Kit  
 Stainless Steel Complete from tank to fuel rail under the cover. Other Custom applications also Available.  
**Without Filter \$517.95. Filter ADD \$181.95**

**GEN III Engine to Tank Stainless Single Fuel Line Kit.**



'55-'57 Chevy Single Fuel Filter/Regulator Line Kit  
 Stainless Steel Complete from tank to fuel rail under the cover. Other Custom applications also Available.  
**Without Filter \$517.95. Filter ADD \$181.95**





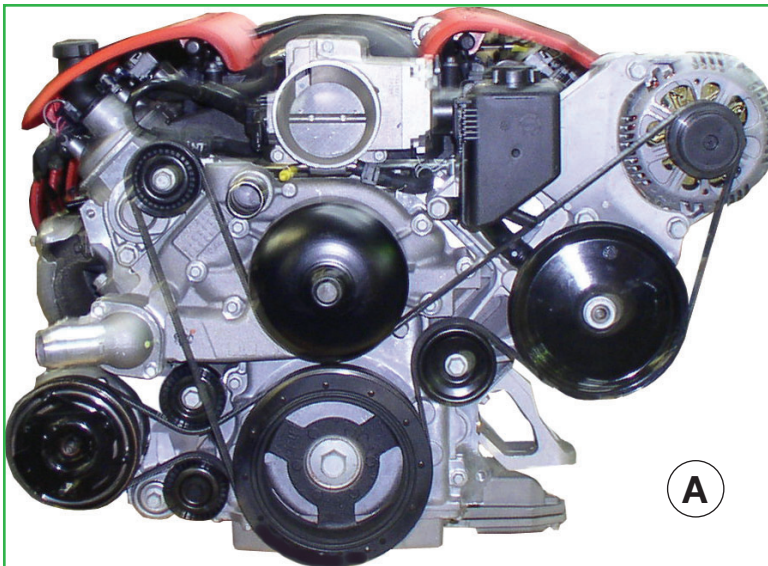

**A**

**97- 04 Factory Vette Accessories**

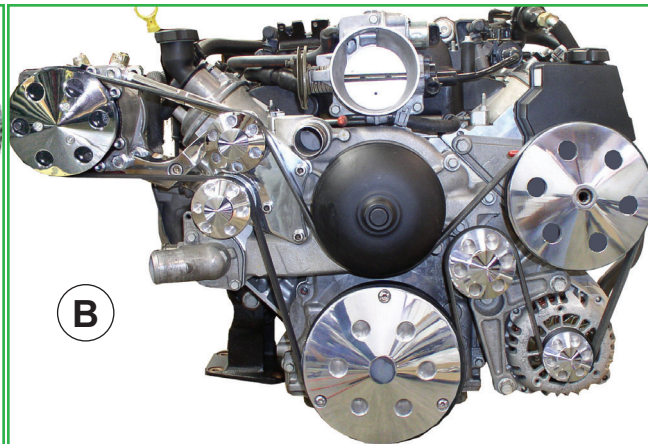

**B**

**IROC/TA with Factory Accessories & S&P Wide Style Air Bracket. Also a complete line of dress up Aluminum pulleys and covers for your GTO / IROC / TA.**

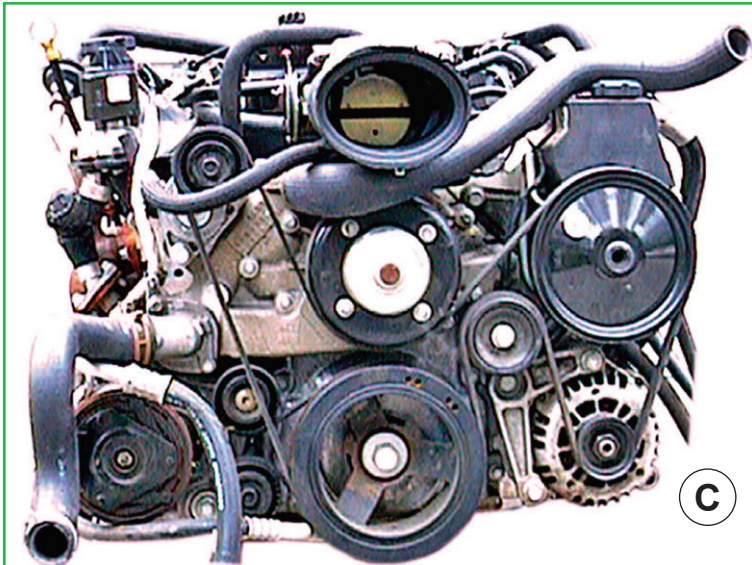

**C**

**98 - 02 LS1 ENGINE (CAMARO / TA)  
Factory set-up**

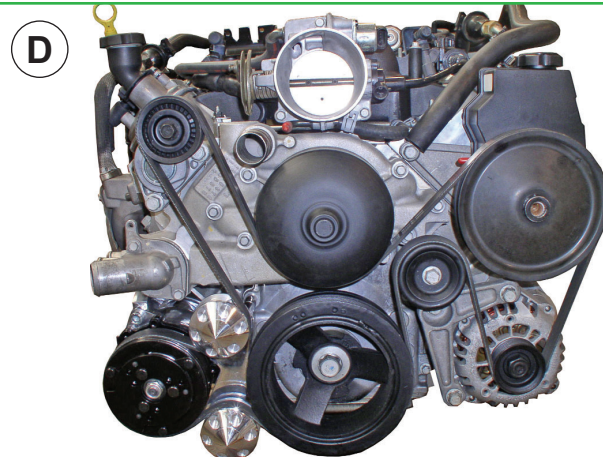

**D**

**Replacement Pulleys Now Available in Aluminum for your Factory Accessories**

**IROC/TA with Factory Accessories & S&P Low Pass. Side Air**



**E**

**99 - Up 4.8, 5.3, 6.0 ENGINE  
Factory set-up**



**F**

**Factory Type Alum. P.S Pulley  
See Page 76**

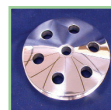

**IROC/TA with Factory P.S & S&P Low Pass. Side Air & Upper Pass. Alt**



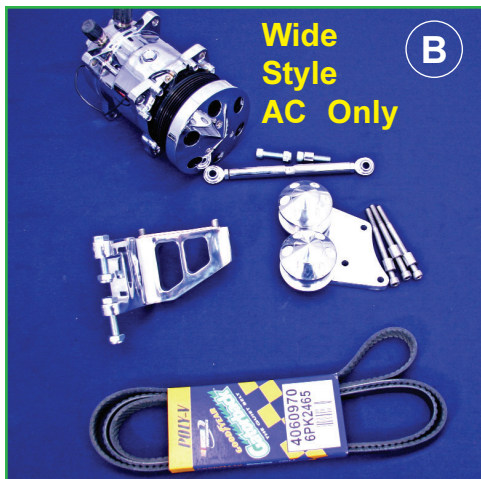

**Wide Style AC Only**

**(B)**

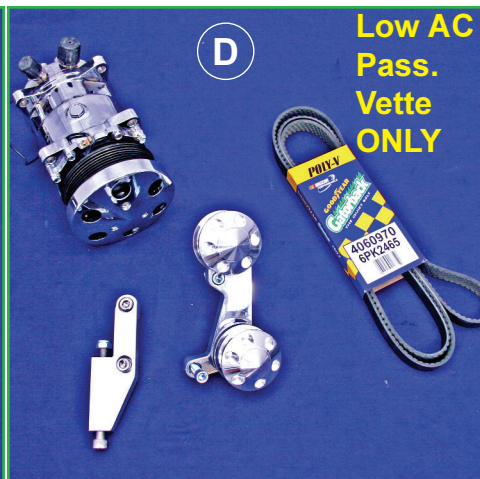

**Low AC Pass. Vette ONLY**

**(D)**

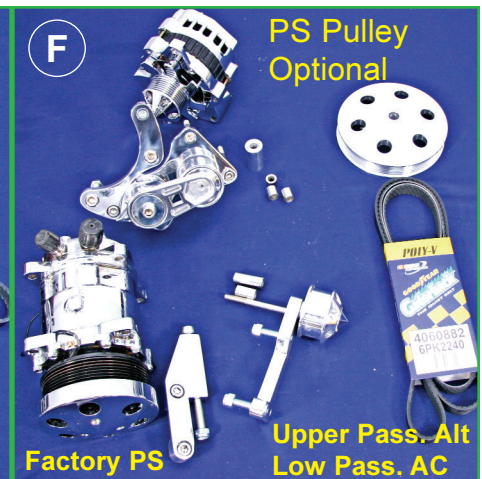

**PS Pulley Optional**

**(F)**

**Factory PS Upper Pass. Alt Low Pass. AC**



**IROC/TA GTO**  
4.8  
5.3  
6.0

**Low AC Pass. ONLY**

**(G)**

Part #

**Add-on Bracket kits to work with Factory Alt & PS**

- B. Wide Style AC Only (Specify IROC / Vette / Truck)
- B. Wide Style AC Only (4.8 5.3 6.0)
- B. AC Bracket, adjusting bar and pass. dual idler kit ONLY
- D. Low AC Pass. (Specify IROC/TA / Vette)
- F. Upper Pass. Alt Low Pass AC (Must Use IROC Balancer)
- G. Low Pass. AC (Specify IROC/TA GTO)
- G. Low Pass. AC (4.8 5.3 6.0)

Polished

Chrome

736.95	866.95
732.95	876.95
362.95	409.95
639.95	747.95
1,808.95	2,033.95
671.95	801.95
683.95	812.95

**S&P keeps a complete line of injectors and provides ultra sonic cleaning of your injectors.**

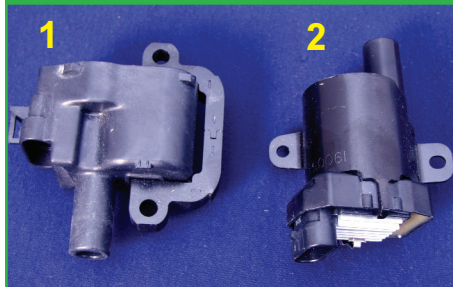

**GEN III Coils**

1. Corvette / IROC/TA . . . \$40.95ea
2. Truck 4.8 / 5.3 / 6.0 . . . \$40.95ea

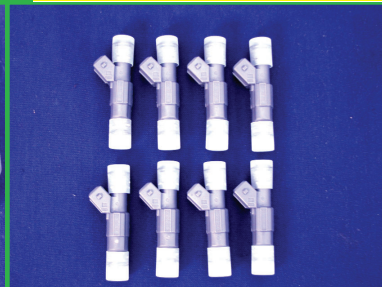

**Injectors**  
Corvette / IROC/TA  
\$465.95 set

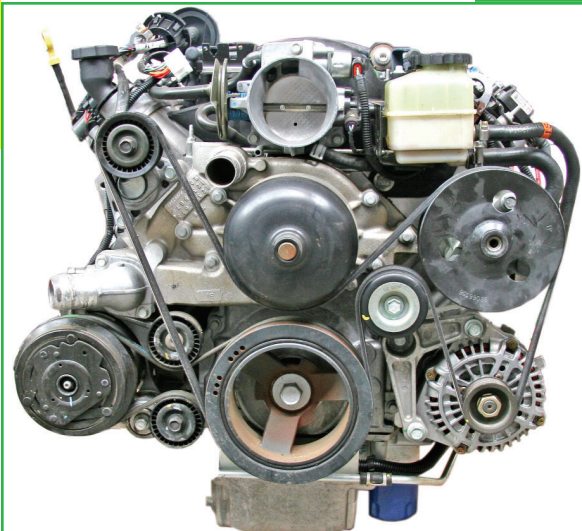

**04 Factory GTO Drive by Cable**



- Aluminum Factory Replacement Pulleys**
1. Ribbed Tensioner Pulley
  2. IROC/TA Power Steering Pulley
  3. GTO Ribbed Power Steering Pulley
  4. Smooth Driver Side Idler Pulley
  5. IROC/TA Alternator Pulley
  6. GEN III Crank Cover

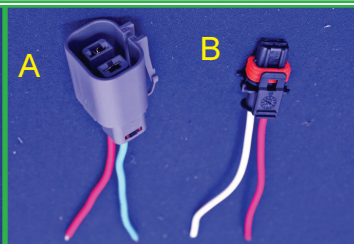

**GM Factory GTO Alt Pig Tail**  
A.05 GTO Alt Pig Tail \$31.95  
B.06 GTO Alt Pig Tail \$31.95

Polished	Chrome
81.95	96.95
105.95	139.95
102.95	124.95
93.95	102.95
48.95	59.95
81.95	97.95

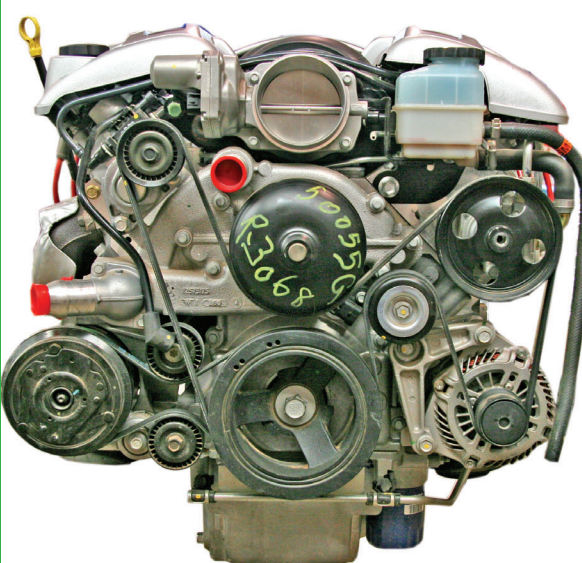

**05-06 Factory GTO Drive by Wire**





**A**

**G Body Cars \$264.95 Exchange**

Custom Oil Pan and Pick-Up Tube Kit for with Stock Front Cross Member.  
 Natural, Polished or Chrome  
 Outright or Exchange with Your Core  
 Core Charge \$295.00  
 See our website for dimensions of other GEN III oil pans



**B**

**55-57/67-69 Camaro \$243.95 Exchange**

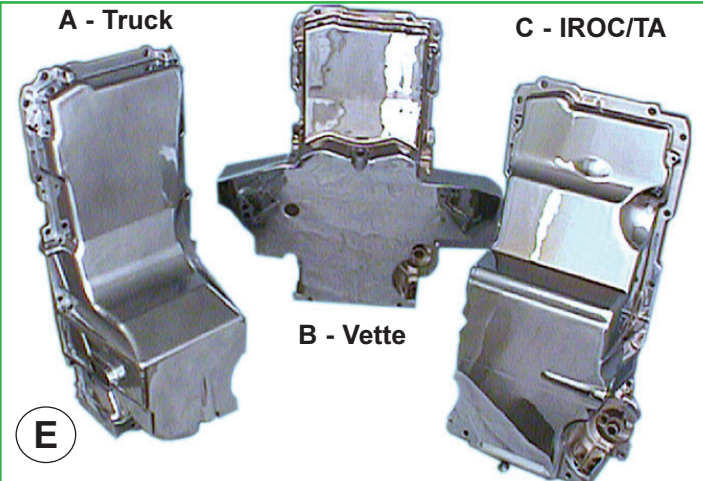

**A - Truck**

**C - IROC/TA**

**B - Vette**

**E**

	Natural	Polish	Chrome
A. Truck Pan	295.95	508.95	647.95
B. Vette Pan	363.95	596.95	735.95
C. IROC/TA	337.95	508.95	647.95
55-57 Modified Pan Exchange	502.95	715.95	922.95
	295.95	544.95	684.95

**With Modified Pans, windage tray is not used.**  
 Pan Kits Complete with Oil Tray and Pick up Tube

**Camaro "Y"**

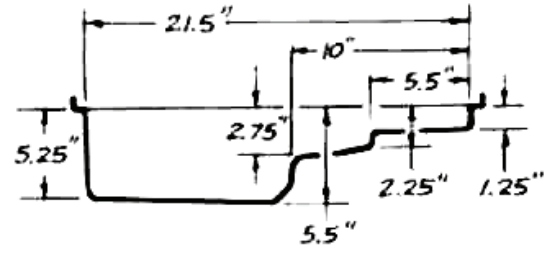

**PN 12558762 Camaro/Firebird (5/5.5 qts.)**

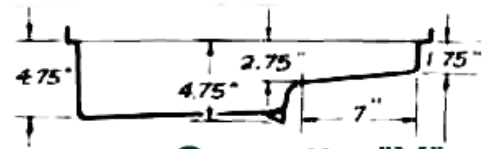

**Corvette "Y"**

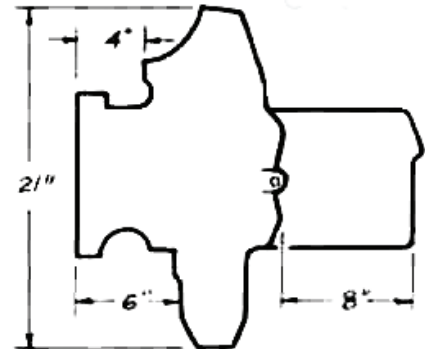

Holden Oil Pan 12561541 (not Pictured) is a Front Sump Oil Pan, can be used in applications with rearward located engine cross member  
**When changing GTO pans to other style pans, dip stick plug must be removed from underside**

**PN 12561828 Corvette (6/6.5 qts.)**

**Truck "C/K"**

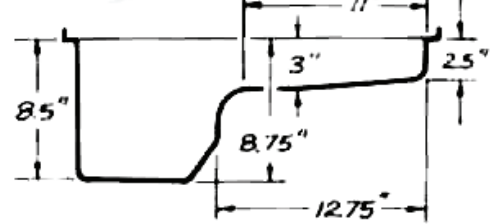

**LS Heater Hose Bibs**

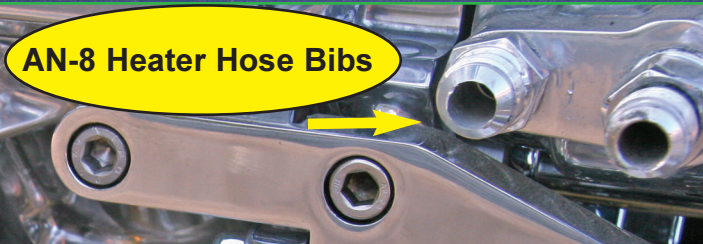

**AN-8 Heater Hose Bibs**

	Anodized	Polish	Chrome
AN-8/10 Heater Hose Bibs			
1. 1/2 Swivel 90 AN-8/10	46.95	56.95	68.95
2. 3/8 Swivel 90 AN-8/10	46.95	56.95	68.95
3. 1/2 to AN-8 Straight	N/A	18.49	20.49
4. 3/8 to AN-8 Straight	N/A	18.49	20.49

Check Web for LS2/LS7 Vette & GTO pan Measurements



G

# LS-1 / 6 Chrome Intakes



S&P LS-1 Aluminum Intake Manifold (Only)....Natural \$569.95....Polished...\$881.95.....Chrome\$1,017.95  
 Chrome Fuel Rails Exchange ..... \$107.95  
 Factory Throttle Bracket ..... \$ 40.95  
 S&P LS-1/LS-6 Name Plate (Holley with Plug) .....Polished \$57.95 ....Chrome \$ 73.95  
 Throttle Body (EXCHANGE) .....Polished \$88.95.....Chrome \$103.95  
 S&P Billet LS1 Throttle Bracket for Lokar Cables.(1 hole or 2 hole) .Polished \$41.95.....Chrome \$ 51.95  
 Lokar Throttle Cable 36" .....Polished \$73.95.....Chrome \$ 83.95

C



### LS-6 - LS-1- Z06 NAME PLATE

Allows you to remove air pump hose and plug w/ LS-1 Name Plate, use w/ Camaro/TA. Polished or Chrome  
 Specify Name plate style and with or without plug.  
 Also Available for Aluminum Holley  
 LS1 Intakes pictured below.Pol.\$48.95 Chrome\$59.95



Name Plate with EGR Plug for Alum. Holley Intake  
 Smooth LS1 LS6 Pol. \$57.95 Chr. \$73.95

### 97-04 Vette

### SUV / Truck

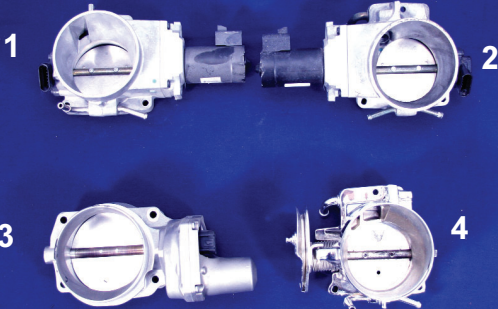

LS-2 05 GTO

Drive by Cable

58 tooth reluctor engines can NOT be drive by cable without changing back to an 24 tooth reluctor ring on the crank shaft. The cam gear on the front of engine also must be changed to an 05 cam gear. See Website for more details.

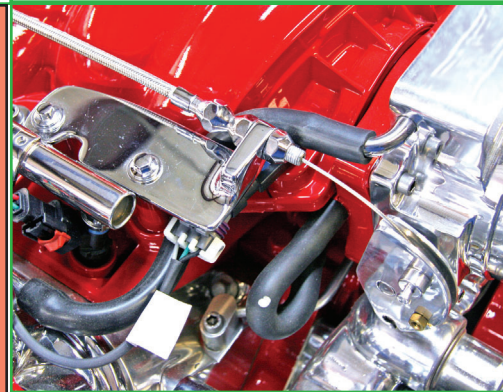

S&P LS-2 Lokar Throttle Cable Bracket Polished \$62.95 Chrome \$72.95

## Engine to Frame Hard Stainless with Braided Hose to AN-6 (37 Degree)

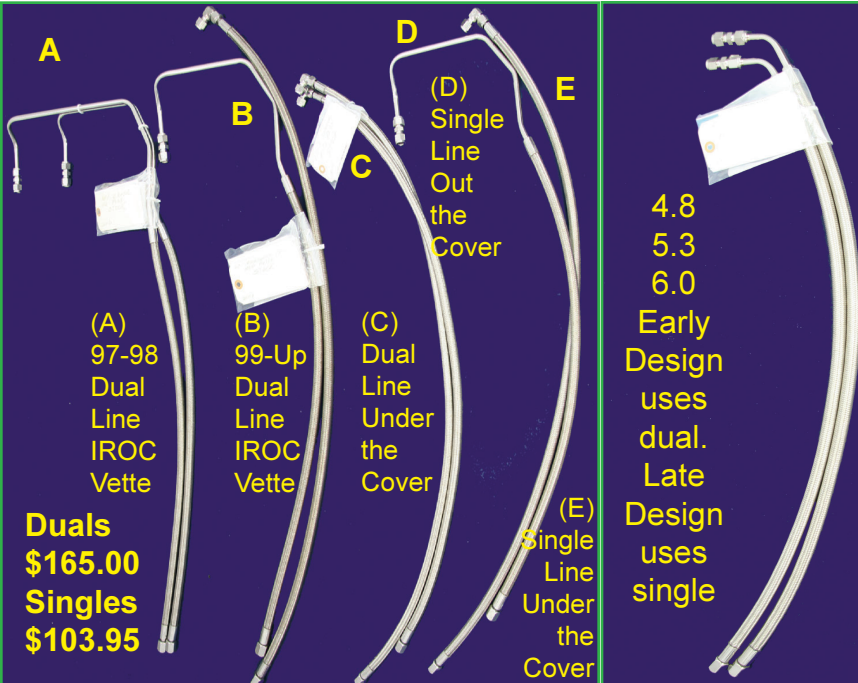

(A) 97-98 Dual Line IROC Vette

(B) 99-Up Dual Line IROC Vette

(C) Dual Line Under the Cover

(D) Single Line Out the Cover

(E) Single Line Under the Cover

Duals \$165.00  
 Singles \$103.95

4.8  
 5.3  
 6.0  
 Early Design uses dual.  
 Late Design uses single

Vette / IROC/TA GTO LS-2 LS-7  
 Specify Driver or Passenger Side

Trucks & SUV

Specify 1 Hole or 2 Hole

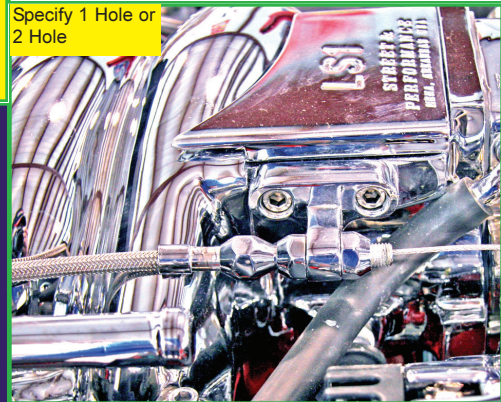

S&P LS-1 LS-6 Lokar Throttle Cable Bracket 1 Hole or 2 Hole Polished \$41.95 Chrome \$51.95

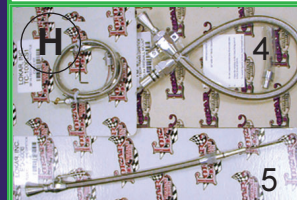

LS-1 Dip Sticks & Throttle Cable Vette/IROC/TA

	Natural	Polish	Chrome
1. 700R4 Detent Cable	85.95	96.95	106.95
350 Detent Cable	85.95	96.95	106.95
2. LS-1 Throttle Cable	63.95	73.95	83.95
FAC LS-1 Throttle Brkt	21.95	NA	40.95
3. Man. Throttle Body	409.95	487.95	NA
4. 4L60E FW MNT	97.95	107.95	88.95
5. LS-1 Eng. Dip Stick	68.95	78.95	78.95





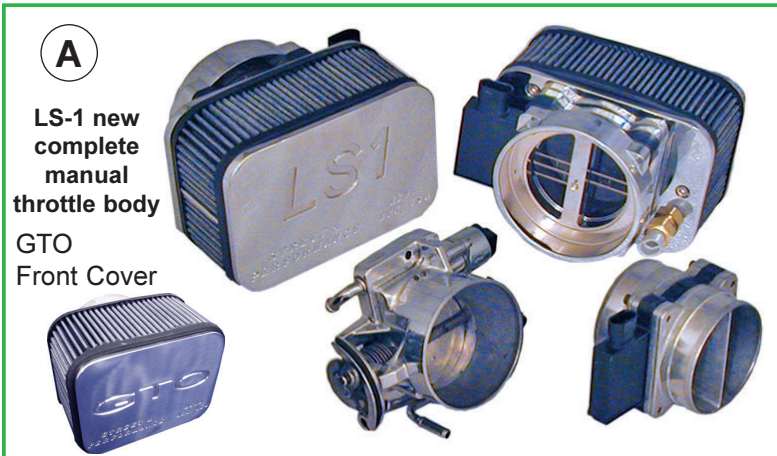

Description	Natural	Polished	Chrome
S&P LS-1 Air Cleaner	N/A	218.95	259.95
S&P LS-6 Air Cleaner	N/A	218.95	259.95
LS-1 Mass Air Flow w/adapter	N/A	187.95	202.95
Elements 1 3/4", 2 1/2", 3", 4"	22.95	-	-
Screw-in LS-1 Air Temp Sensor	35.95	-	41.95
Manual LS-1 throttle body comp	409.95	497.95	516.95

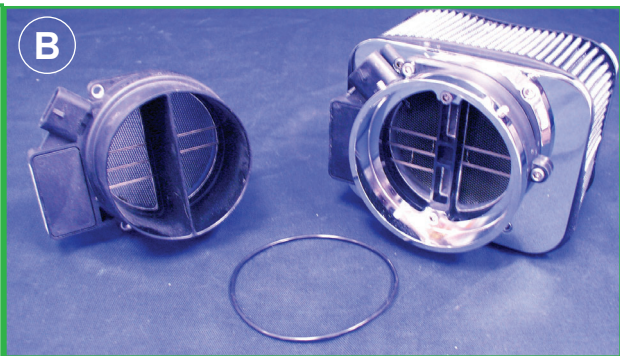

**Air Cleaner Adapter for Truck & LS-1 Plastic 5 Pin Mass Air Flow**

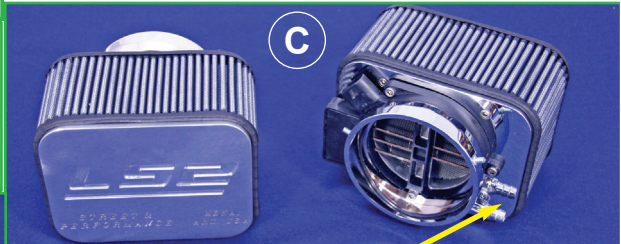

**LS2 Air Cleaner using 5 Pin MAF adapter with PCV Vent**



	Natural	Polished	Chrome
A. K&N Air Cleaner	57.95	N/A	N/A
B. 90 Degree Alum. Elbow for 5 Pin MAF (Includes 2 Clamps and 1 Coupler)	118.95	151.95	189.95
B. 90 Degree Alum. Elbow for 3 Pin MAF (Includes 2 Clamps and 1 Coupler)	118.95	151.95	189.95
C. Alum. 5 pin MAF adapter to TB.	N/A	42.95	68.95
D. Alum. 3 pin MAF adapter to TB.	N/A	47.95	73.95
E. Screw in Air Temp for 3 pin MAF.	35.95	N/A	43.95

**F. 4" ALUMINUM TUBING per ft.**

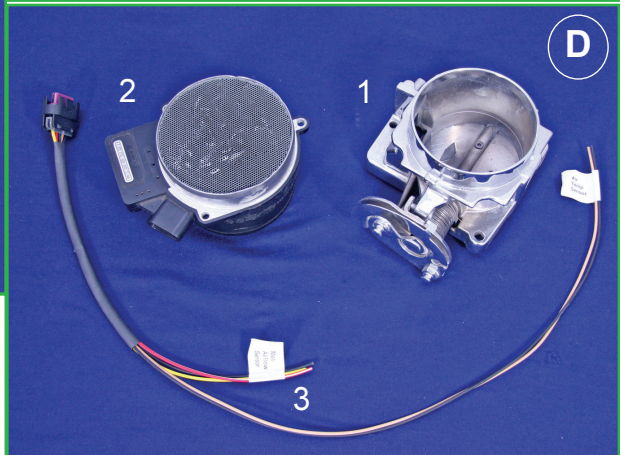

- LS-1/LS-6 Units and Adapter**
- 1. 76mm Manual LS-1 Throttle Body . . . . . \$409.95 (Polished Exchange) . . . . . \$88.95 (Chromed Exchange) . . . . . \$104.95
  - 2. LS 5 Pin Mass Air Flow Unit . . . . . \$145.95
  - 3. LS 5 Pin Mass Air Flow Adapter Pig Tail . . . \$25.95

**Now ! 90 MM 5 Pin Mass Air Flow Air Cleaner Adapters. Must specify when ordering, air cleaner.**

Pol. \$575.95 Chrome \$616.95

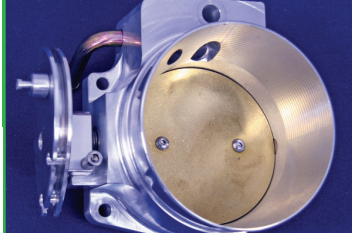

**Billet 90 mm Throttle Body Drive by Cable for LS1 / LS6 / LS-2 \$513.95**

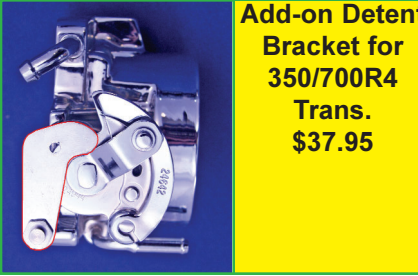

**Add-on Detent Bracket for 350/700R4 Trans. \$37.95**

**2 MAF RUBBER COUPLERS with Clamps**



- 1. 3 Pin MAF \$ 47.95
- 2. 5 Pin MAF \$ 47.95
- 3. 4" Coupler \$ 26.95



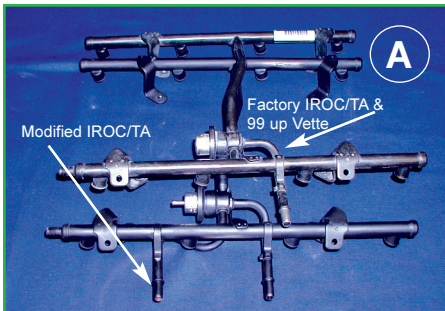

**Modified IROC/TA Fuel Rail Conversions**  
 Black Modified LS-1 Fuel Rails w/reg ..... \$175.95  
 Chrome Modified LS Fuel Rails w/reg ..... \$275.95  
 3/8" S.S Compression Fittings to AN6 ..... \$ 40.95  
 5/16" S.S Compression Fittings to AN6 ..... \$ 40.95

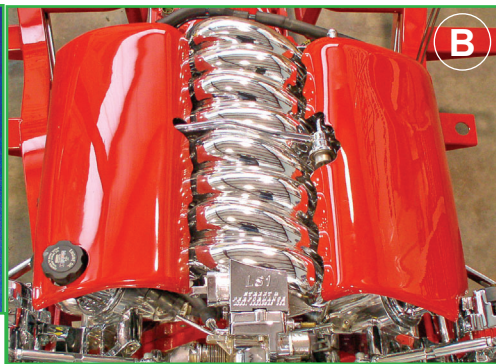

**Custom Smooth LS-1,2,3,6,7 Top Covers**  
 Paintable. \$258.95 per set

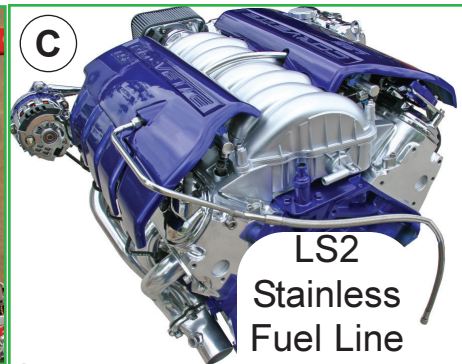

**LS2 Stainless Fuel Line Kit**  
**\$108.95**

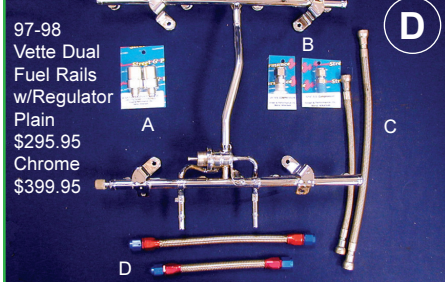

**97-98 Vette Dual Fuel Rails w/Regulator**  
 Plain \$295.95  
 Chrome \$399.95

A. Alum. Quick disconnect to # AN.....\$42.95ea  
 B. S.S Compression to #6 AN.....\$40.95ea  
 C. 97-98 Factory Fuel Hose (Pair).....\$96.95  
 D. S&P Braided 6AN Hose with Ends \$ 8.95 per ft.



**LS2 Top Covers \$127.95**  
 Can be painted to match Vehicle

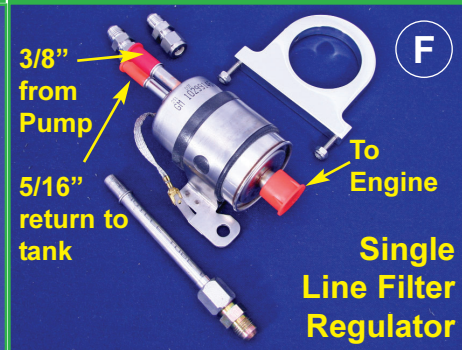

**Single Line Filter Regulator**  
 Uses 99-Up Vette fuel filter, allows the use of one line to engine. Filter will return excess fuel to tank. \$181.95 Bracket Optional. Pol. \$37.95 Chrome \$47.95



**Dual Line**  
**S&P Fuel Filter Kit**  
 Polished G.M. S.S. Filter, 2-16mm o-ring to #6, w/polished alum mounting Bracket and stainless mounting bolts.  
 #000009500 Complete Kit ..... \$86.95  
 #00000100 Polished Filter Only ..... \$38.95

**LS-1 Hi-Torque Gear Reduction Starter with bolts**  
 Specify Year of Engine

Plain ..... \$254.95  
 Polished ..... \$321.95  
 Chrome ..... \$382.95



A. 99 - up LS1 Vette Top Covers (pair) ..... \$105.95  
 B. 97 - 98 LS-1 Vette Top Covers (pair) ..... \$93.95



**LS-6**  
 '99 Up Red Top Covers  
 00000000 pair .... \$155.95

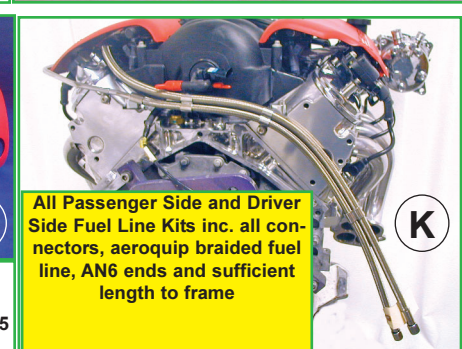

All Passenger Side and Driver Side Fuel Line Kits inc. all connectors, aeroquip braided fuel line, AN6 ends and sufficient length to frame

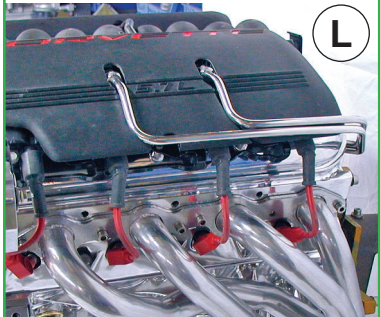

**97-98 IROC/TA 97-98 Vette S.S Fuel Hardline Kit**

**LS-1 / LS-6 Fuel Line Components**  
 The 97-98 Vettes use dual fuel lines one in and one out, like LT-1's & TPI's. The 99 up Vettes use one fuel line w/regulator built into tank w/ a Tee in the feed line. Modified fuel rail & Rear Exit Kits will simplify your installation.

Part #	Rear Exit Fuel Line Kits	Polished
00000000	1. 97-98 Vette Dual Pass/Side Outlet .....	175.95
	2. 97-98 Vette Dual Driver/Side Outlet .....	175.95
	3. 98 IROC w/modified fuel rails (driver side) .....	175.95
	4. 98 IROC w/modified fuel rails (pass side) .....	175.95
	5. 98 IROC w/Vette fuel rails (driver side) .....	175.95
	6. 98 IROC w/Vette fuel rails (pass side) .....	175.95
	7. 99-Up IROC w/modified fuel rails (driver side) ..	175.95
	8. 99-Up IROC w/modified fuel rails (pass side) ...	175.95
	9. 99-Up Vette w/modified fuel rails (driver side) ..	175.95
	10. 99-Up Vette w/modified fuel rails (pass side) ...	175.95
	11. 99-Up Vette w/Vette fuel rails (driver side) .....	175.95
	12. 99-Up Vette w/Vette fuel rails (pass side) .....	175.95
	Pol S.S Fuel Filter Kit w/bracket & AN6 Fittings ...	86.95

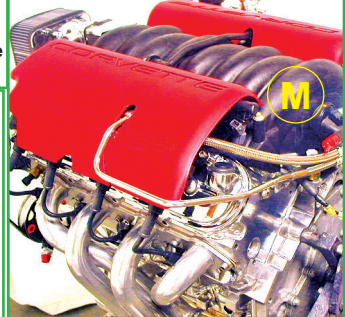

**99-Up IROC/TA 99-Up Corvette S.S Fuel Hardline Kit**





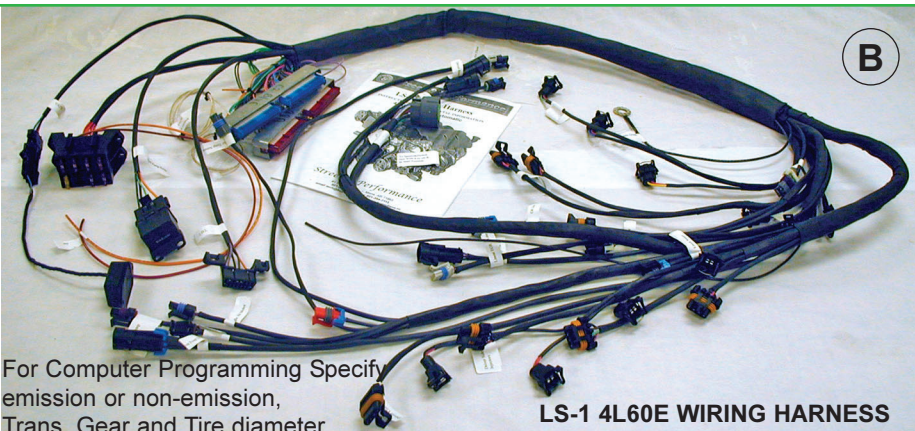

For Computer Programming Specify emission or non-emission, Trans, Gear and Tire diameter.

**LS-1 4L60E WIRING HARNESS**

**LS-1 AUTOMATIC TRANS. DRIVE BY CABLE WIRING HARNESS**

LS-1 are designed for easy of installation, come ready to plug in with only 4 wires to hook-up. All harness are available with full emission. Also have harness up through 2003.

16238212	97 - 98 LS-1 Vette/IROC/TA Wiring Harness complete for 4L60E	.....\$ 822.95
9354896	99 - up LS-1 Vette/IROC/TA Wiring Harness complete for 4L60E	.....\$ 926.95
9354896	99 - up LS-1 <b>Truck Wiring</b> (4.8-5.3-6.0) Harness for 4L60E/4L80E	.....\$ 926.95
12576106	97 - up LS-1 <b>Drive by Wire</b> Harness for Manual or 4L60E/4L80E	.....\$ 983.95

**Need to know if you have a 3 Pin or 5 Pin MAF**

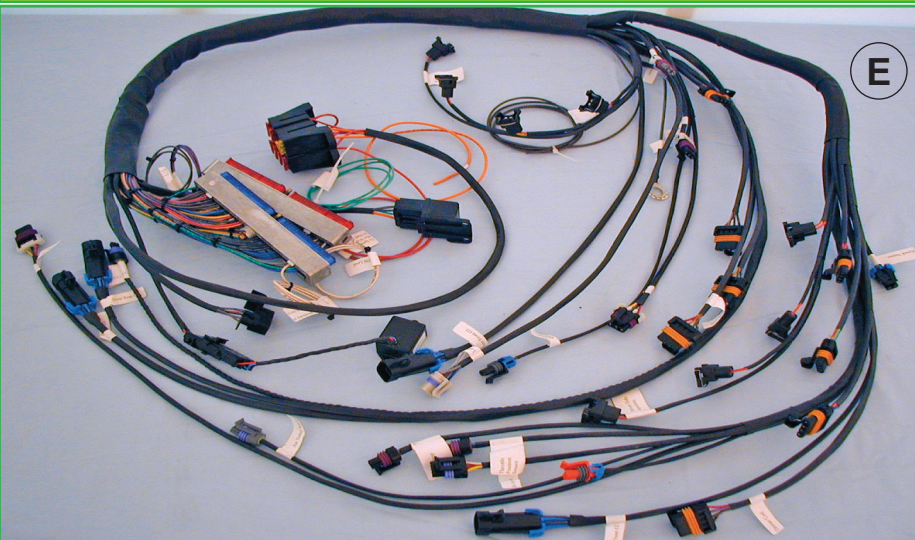

**LS-1 MANUAL TRANS. DRIVE BY CABLE WIRING HARNESS**

LS-1 are designed for easy of installation, come ready to plug in with only 4 wires to hook-up. All harness are available full emission and compatible with other manual transmissions.

16238212	97 - 98 LS-1 Vette/IROC/TA Wiring Harness complete for Manual 6-speed	.....\$ 822.95
9354896	99 - up LS-1 Vette/IROC/TA Wiring Harness complete for Manual 6-speed	.....\$ 926.95
9354896	99 - up LS-1 <b>Truck Wiring Harness</b> for Manual Transmission	.....\$ 926.95

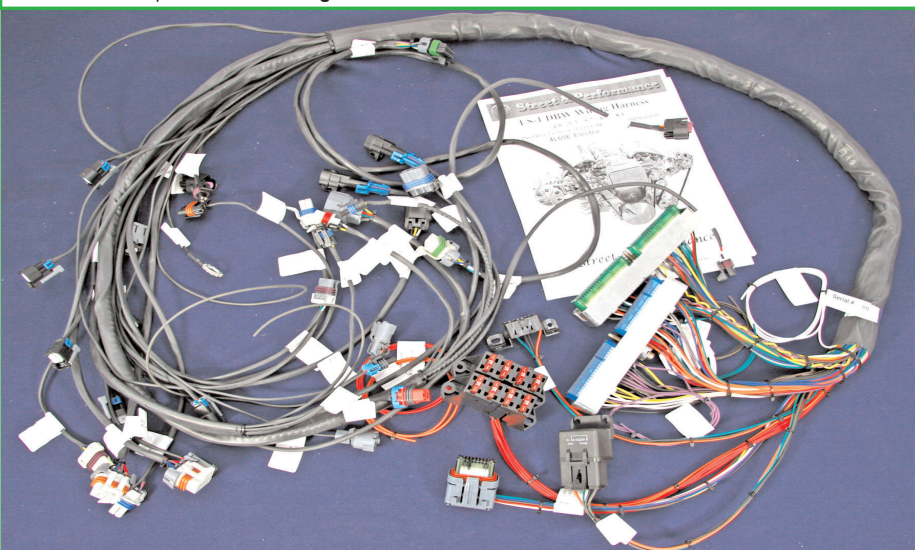

**GTO / SUV / Truck Drive by Cable**  
(For vehicles using Blue & Green Plug Computer)

3 pin MAF



Computer Programming  
\$258.95 With  
Harness  
Purchase

1997 - 1998 Vette ~ IROC ~ T/A ~ Trucks .  
(Red & Blue Plug)  
#16238212 / 16232148 .....\$ 144.95  
Core Charge .....\$ 310.95  
Custom Programming w/o harness ..\$ 310.95



1999 & up Vette ~ IROC ~ T/A ~ Trucks .  
(Red & Blue Plug)  
99-2000 #09354896 / #16263494 .....\$ 144.95  
2002 #12200411 .....\$ 144.95  
Core Charge .....\$ 310.95  
Custom Programming w/o harness ..\$ 310.95



2004 Drive by Wire  
(Blue & Green Plugs)  
Custom Programming w/o harness .....\$ 310.95



**LS Tach must be able to set on four cylinder**

Universal Speedometer Signal Interface, Recalibrates Speed Signal to Correct for Gearing and Tire size Changes Unit can also Solve Pulse Rate Incompatibility Problems by Converting a Pulse Rate to Multiple Lower or Higher Pulse Rates. **Not for use with Anti-Lock Brake Systems.....\$82.95**

**If you are using Classic Instruments Speedometer or a non-programmable speedometer you will need this speed signal interface.**

The new SGI-8 Tach Signal Interface unit is capable of recalibrating most tachometer signal to make them work with tachometers originally designed for a different number of cylinders. For instance, if you have put a V-8 into a vehicle with a factory tachometer that was originally equipped with a 4 or 6 cylinder engine, the SGI-8 would be able to alter the tach signal so that the factory tach will read correctly. **\$82.95**

**LS-1, If tach is not programmable, you will need this tach signal interface to make your tach work.**





03-04 Computers can only be Programmed as Drive By Wire.  
12586243 Pictured Above  
(Blue & Green Plugs)

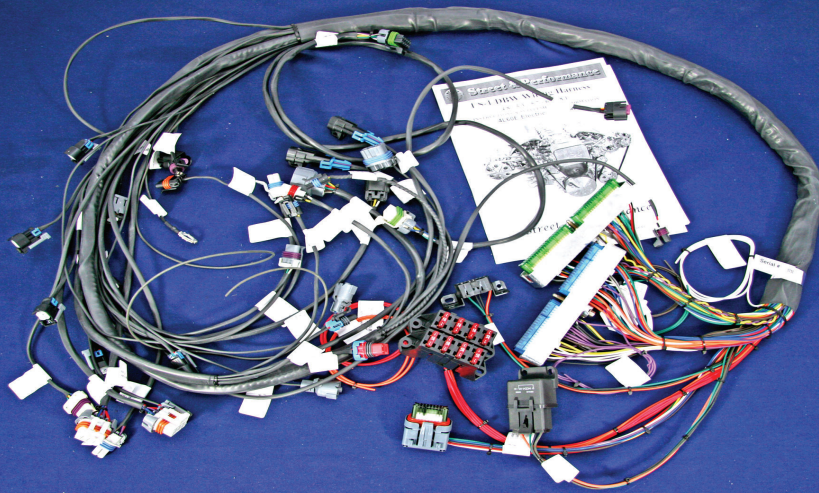

2004 Up Drive by Wire  
(using computer # 12586243)  
for 3 pin MAF

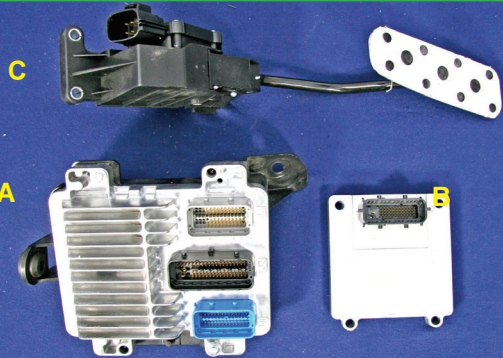

- A. 05 LS2 Computer 12597883.....\$ 453.95
- B. Transmission Controller..... \$ 298.95
- C. GTO DBW Throttle Pedal Assem.....\$ 281.95

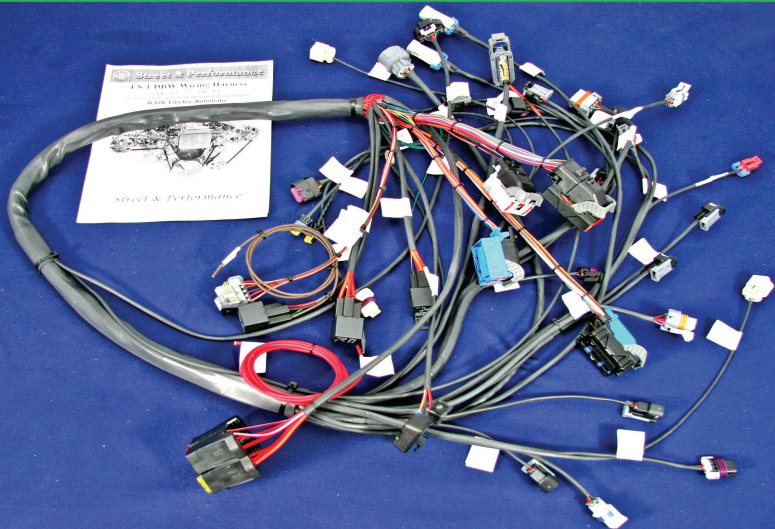

05-06 - LS-2 - GTO - SSR - DRIVE BY WIRE

SERV NO.	ENGINE/VEHICLE
9254896-	99-00 4.8, 5.3 & 6.0
12200411-	01-02 4.8, 5.3, 6.0 & 8.1
12200411-	01-03 IROC/TA Vette LS1/LS6
12586242-	04 Vette LS1/LS6
12576106-	03 4.8, 5.3 & 6.0
12586243-	04 4.8, 5.3 & 6.0
12589463-	05-06 4.8, 5.3 & 6.0 (24 Tooth reluctor)
12597191-	05 Vette LS2 (24 Tooth reluctor)
12597883-	05 Vette LS2 (24 Tooth reluctor)
12598343-	04 GTO / SSR (24 Tooth reluctor)
12597883-	05 GTO / SSR (24 Tooth reluctor)
12603892-	06-07 LS-2/LS-7 (58 Tooth reluctor)
12583560-	06 4.8, 5.3 & 6.0 (24 Tooth reluctor)
12583561-	06 4.8, 5.3 & 6.0 (24 Tooth reluctor)
12596679-	06 5.3 SSR (24 Tooth reluctor)
12597121-	07 up 4.8, 5.3 & 6.0 (58 Tooth reluctor)

When getting the donor engine and transmission, get the **MASS AIR FLOW, COMPUTER, TAC MODULE, GAS PEDAL, OXYGEN SENSORS**. S&P keeps a complete line of new and used accessories.

03-Up Truck Injectors 4.8 5.3 6.0



Flex Fuel  
Z-style

Old Style STD  
metal bale clip

T-Style  
Delphi 45 plug

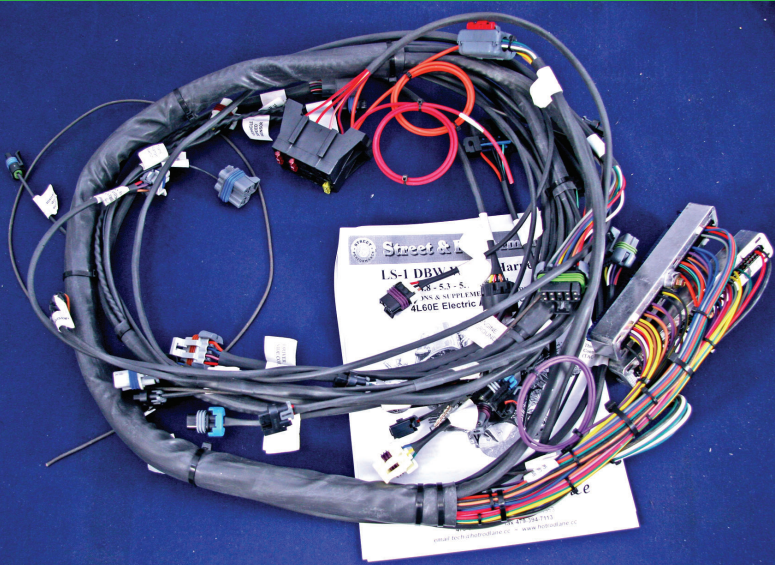

03 Up 4.8 / 5.3 / 6.0 Drive by Wire  
Engine Wiring Harness Manual or Automatic  
Must know what style injector you have. See Left.





All S&P Headers have S.S. Flanges

All welds on ID are ground smooth for good looks and maximum flow.  
**CHROMEX Coating** inside and out

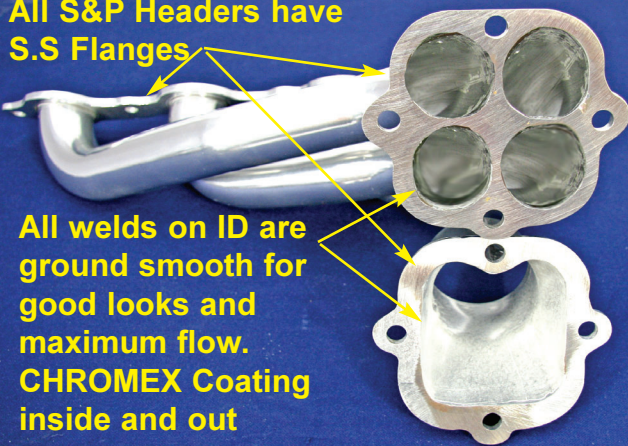

## Nova Headers

Plain \$448.95  
 Coated \$577.95

All S&P Headers come with Gaskets, Bolts, Collectors and O2 Buns



See Your Local Hot Rod Shop or give us a call.  
 Check our website for New LS products & Installations

4.8  
 5.3  
 6.0

Taylor Plug Wires



Specify Year & Type



Taylor Custom LS-1 Spark Plug Wires  
 Set ..... \$102.95  
 Custom Colors ..... \$ 122.95  
 Blue ~ Black ~ Red ~ Yellow ~ White

\$175.95 Set



LS Mount Kit into Late SS Impala / Caprice

S&P Headers are coated in house and carry a three year warranty.



Biscuit Mounts & Alum. stands are great for Street Rods

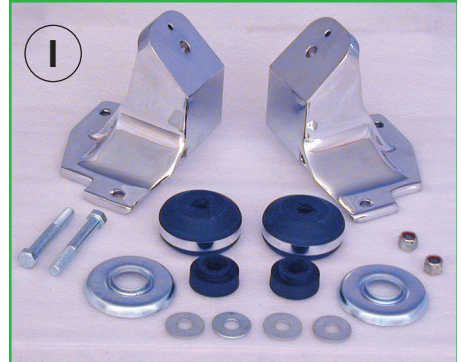

Factory Vette LS-1 Aluminum Motor Stands rubber biscuit motor mounts optional.

**GEN 3 Motor Mount Plates**  
 Allows you to bolt LS-1 to Original V-8 Motor Mounts on most all vehicles with Chevrolet V-8 Motor Mounts

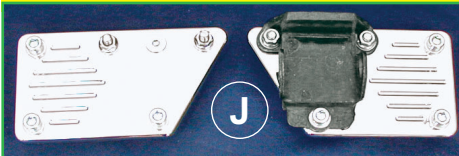

LS-1 Motor Mount Plates come complete with all metric and standard bolts



Special Plates to move engine back 1" farther than plates above

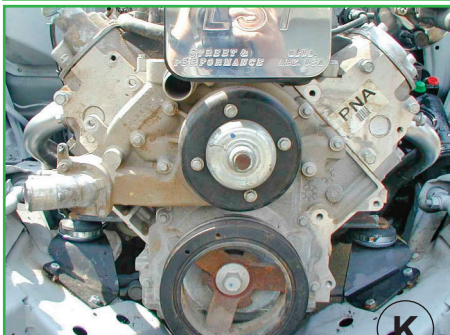

55-57 Motor Mount Kit- with LS-1 Motor Mount Plate needs to be added to kit

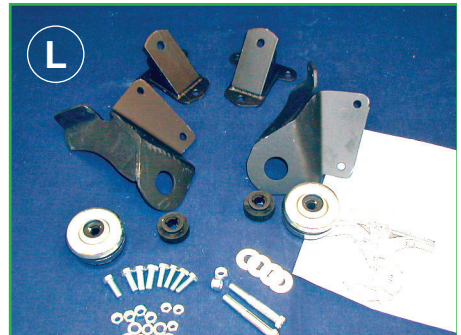

**55-57 Front Motor Mount Kit**  
 Kit allows you to put any SBC/BBC into 55-57

We keep a full stock of fuel pump assemblies; call for your application and tech...

Part#	LS-1 Motor Mounts and Accessories	Natural	Polished	Chrome
	LS1 Motor Mount Adapter Plates .....	97.95	118.95	151.95
	LS1 Motor Mount Adapter Plates (1" Longer) .....	107.95	129.95	161.95
	'55-'57 Front Motor Mount Kit .....	118.95	N/A	N/A
	Natural Vette Aluminum Stands w/ Bolts .....	125.95	215.95	300.95
	Biscuit Motor Mount Kit .....	31.95	N/A	N/A



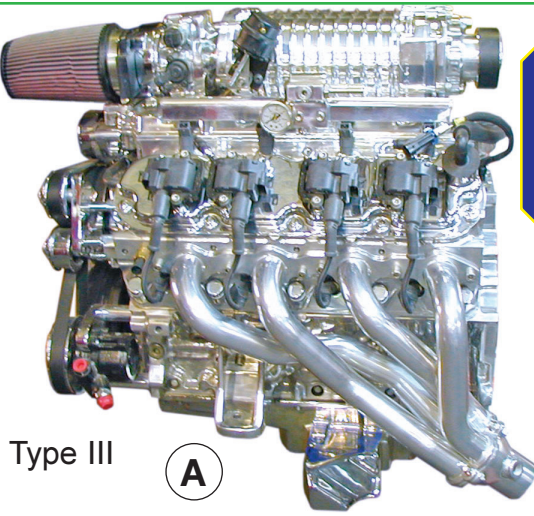

Type III

**A**

All S&P Headers are coated with **CHROMEX** in house and carry a three year limited warranty.

All Stainless Steel Flange and all welds inside ground smooth for maximum flow and performance. All S&P headers come with gaskets and stainless steel bolts

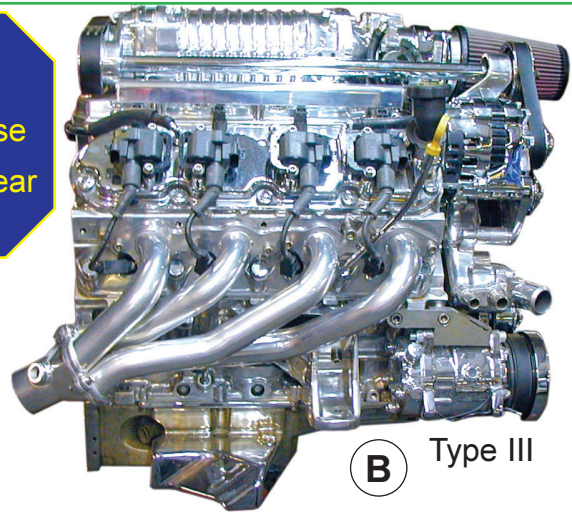

Type III

**B**

**LS-1 - LS-6 Driver Side and Passenger Side Rear Dump Headers**  
 S&P Pro-Car LS-1 Type III Rear Dump Header fits most Hot Rods with sub-frames or cross member under front of oil pan, G-Bodies, El Camino, Monte Carlo, Mid 50's and Later Pick-ups including late model. Not For Use in Emission Controlled Vehicles.

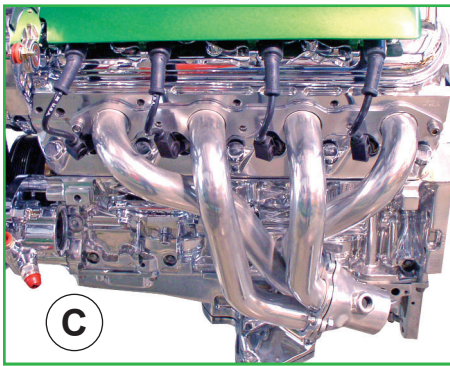

**C**

**Drivers Side Street Rod Headers**  
 Comes w/O2 Sensor already installed, works in almost all Corvette's

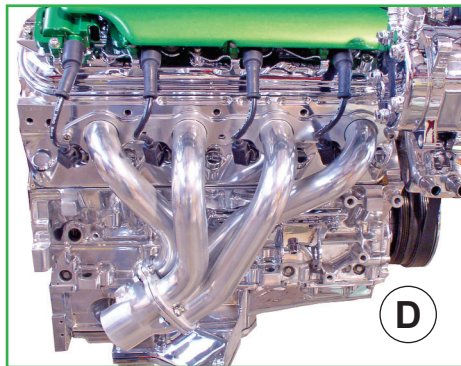

**D**

**Passenger Side Street Rod Headers**  
 Options, Polished Stainless Collectors



**E**

NOW with **CHROMEX**

**LS-1 G-Body Headers (Monte Carlo Style)**  
 All Street & Performance Headers have Stainless Steel Head Flanges and Collector Flanges for better gasket sealing. Headers come complete with Street & Performance special design gaskets which have a thin layer of metal between the material. All Headers are available plain steel or thermo coated inside and out.

Street & Performance leads the way in the development of Pro-Car Headers for the 55 - 57 Shoe Box - LS-1 Conversion

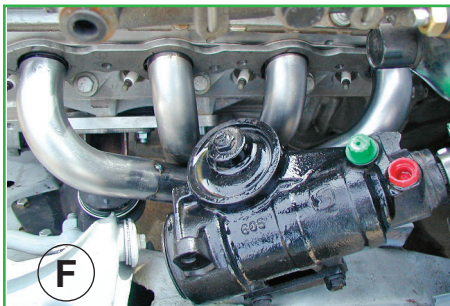

**F**

**Driver Side 55 -57 Chevy**  
 Will clear stock gear box and 605



**G**

**Passenger Side 55 - 57 Chevy**  
 Also available for rack & pinion vehicles

54-96 Vette Headers - Plain	445.95
54-96 Vette Headers - Thermo Coated	554.95
G-Body Headers - Plain	463.95
G-Body Headers - Thermo Coated	577.95
67-69 Camaro/Chevelle - Plain	463.95
67-69 Camaro/Chevelle - Thermo Coated	577.95
55 - 57 Headers - Plain	437.95
55 - 57 Headers - Thermo Coated	550.95
Street Rod Headers - Plain	426.95
Street Rod Headers - Thermo Coated	550.95
Street Rod Tight Tuck - Plain	416.95
Street Rod Tight Tuck - Thermo Coated	534.95
Complete w/collectors, gaskets, and stainless bolts	
O2 Sensor (ea)	77.95
O2 Simulators (ea)	82.95
Steel Bun only (ea)	19.95
Replacement Flange Gaskets (ea)	16.95
Replacement Collector Gasket (ea)	7.95
Polished Stainless Collectors w/O2 (ea)	94.95



NOW in Stainless Steel

**New Street Rod "Tight Tuck"**

**H**

**New Style Street Rod "Tight Tuck" Headers for Speedstars, Coast to Coast and Boyds.**



**Stainless Steel Collectors w/O2 Buns**

**I**

**Pol SS LS1 Collectors w/ SS O2 Buns**  
 Optional: w/ Headers when running stainless exhaust.



**Street Rod Style**

**J**

All Street & Performance Headers come complete w/ Collectors, O2 Buns, Gaskets and Bolts





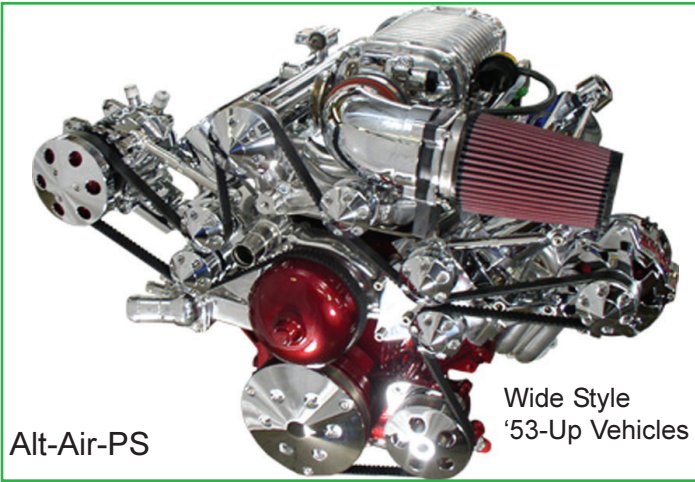

Alt-Air-PS Wide Style '53-Up Vehicles

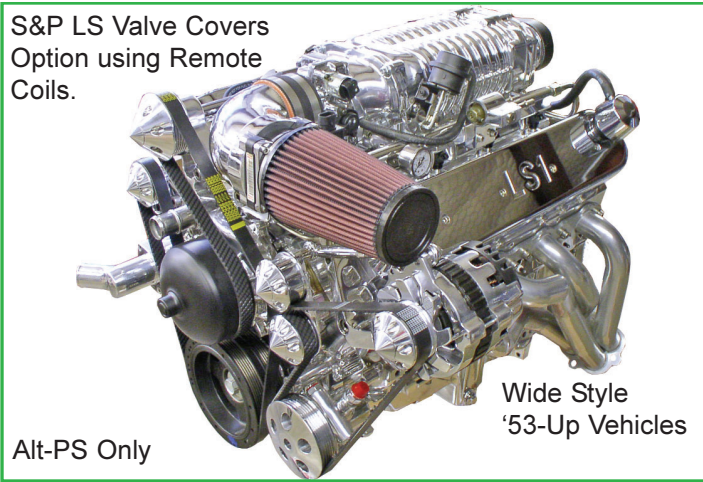

S&P LS Valve Covers Option using Remote Coils. Alt-PS Only Wide Style '53-Up Vehicles

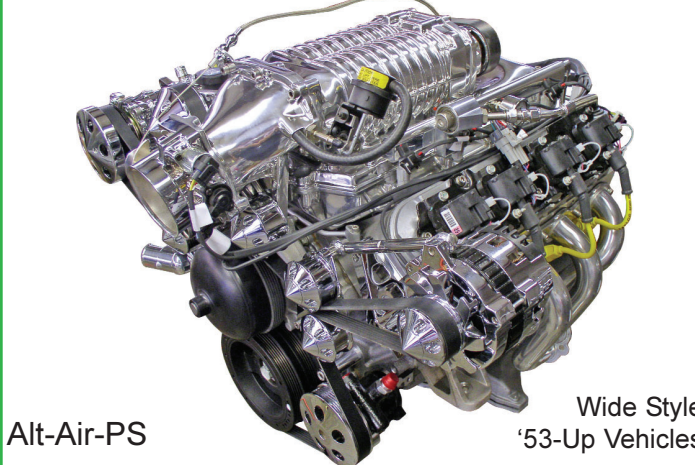

Alt-Air-PS Wide Style '53-Up Vehicles

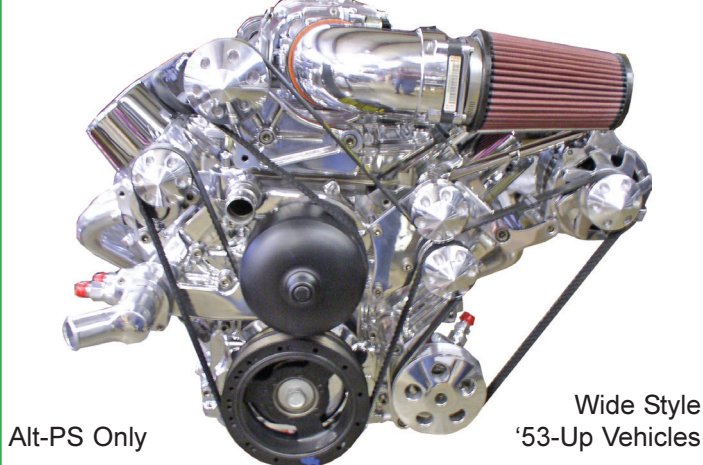

Alt-PS Only Wide Style '53-Up Vehicles

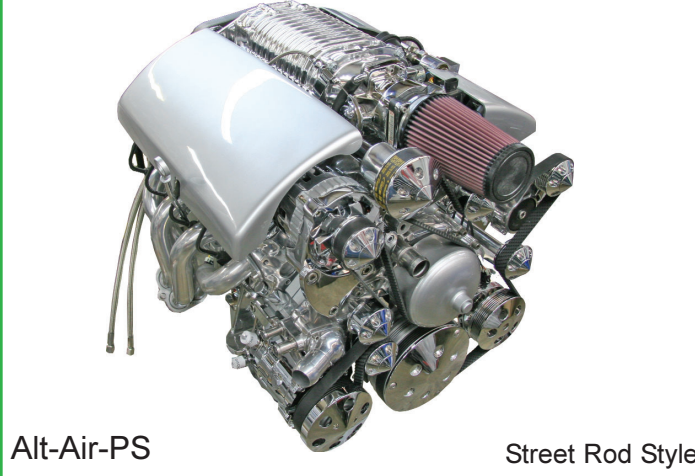

Alt-Air-PS Street Rod Style

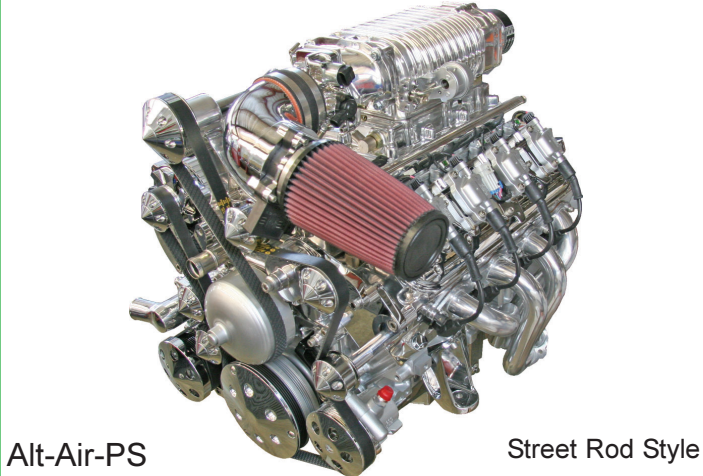

Alt-Air-PS Street Rod Style

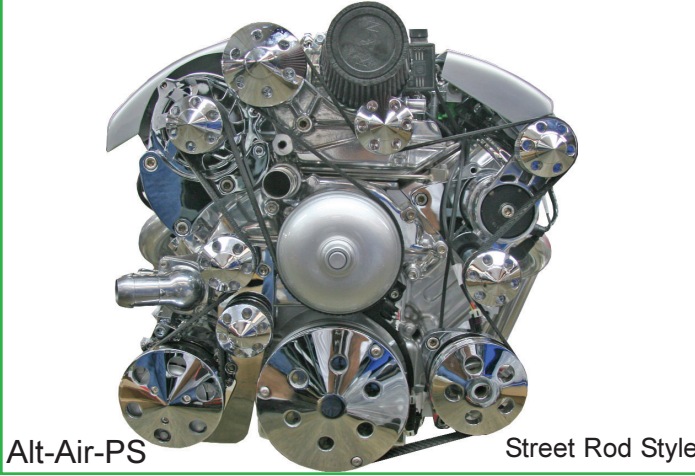

Alt-Air-PS Street Rod Style



Call us for Your Application. Intercooler Optional

Comes with Injectors and programming of your computer included



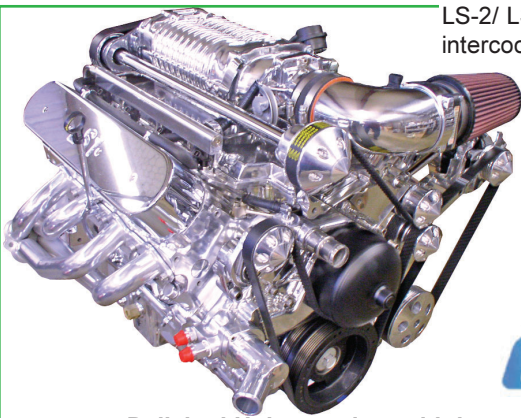

LS-2/ LS-6 Must use intercooler



**Polished Unit complete with intercooler and heat exchanger. Custom computer program fee \$414.95**

**MAGNACHARGER  
\$5500.00 Complete**

Polished Add \$823.95 / Intercooler add \$517.95  
(Includes Intake, Blower, Injectors and Reprogramming of PCM)  
In Excess of 470 HP on Pump Gas.

Your results may vary based on engine condition and use of after market products. New 5th generation Magna Charger MP 112 MP122 Also Available which produces 40 HP over 5000 RPM (OE approved Eaton rotating group)  
For More Information Check our Website: [www.hotrodlane.cc](http://www.hotrodlane.cc)



**Will Clear Roller Rocker Arms. With or without PCV Breather Holes.**

**Comes complete with s.s bolts and GM gaskets.**

**New S&P 99-UP  
LS-1/LS-6 Aluminum Valve Covers for remote coil applications**  
Custom Designs are available.  
Polished.. \$428.95 Chrome..\$531.95  
Custom length Taylor LS-1 plug wires.. \$144.95

Part#	LS-1 Bracket & Accessories - Street Rod and Vette Style All Kits complete w/bolts, fasteners and s.s adjusting bars	Polished	Chrome
	Vette Style Alt & Air Bracket Kit (Vette) .....	317.95	350.95
	Vette Style Alt & Air Bracket Kit (IROC/TA) .....	317.95	350.95
	LS-1 Vette Style Idler Kit (4 idlers, 2 brackets (Vette) .....	398.95	463.95
	LS-1 Vette Style Idler Kit (4 idlers, 2 brackets (IROC/TA) .....	398.95	463.95
	LS-1 Vette Style Power Steering Kit - bracket, pump & pulley (Vette) .....	302.95	322.95
	LS-1 Vette Style P/S Kit - bracket, pump, pulley (IROC/TA) .....	302.95	322.95
	LS-1 Vette Style Alt (only) Bracket Kit (Vette) .....	156.95	189.95
	LS-1 Vette Style Alt (only) Bracket Kit (IROC/TA) .....	156.95	189.95
	LS-1 Vette Style Alt (only) Idler Kit - 3 idlers, 2 brackets (Vette) .....	329.95	382.95
	LS-1 Vette Style Alt (only) Idler Kit - 3 idlers, 2 brackets (IROC/TA) .....	329.95	382.95
	Street Rod Low Driver Side Alt (only) Bracket Kit (Vette) .....	156.95	189.95
	Street Rod Low Driver Side Alt (only) Bracket Kit (IROC/TA) .....	156.95	189.95
	Street Rod Low DS Alt (only) Idler Kit - 3 idlers, 2 brackets (Vette) .....	329.95	382.95
	Street Rod Low DS Alt (only) Idler Kit - 3 idlers, 2 brackets (IROC/TA) .....	329.95	382.95
	Street Rod Low Pass Side Alt (only) Bracket Kit (Vette) .....	189.95	216.95
	Street Rod Low Pass Side Alt (only) Bracket Kit (IROC/TA) .....	189.95	216.95
	Street Rod Low PS Alt (only) Idler Kit - 3 idlers, 2 brackets (Vette) .....	329.95	382.95
	Street Rod Low PS Alt (only) Idler Kit - 3 idlers, 2 brackets (IROC/TA) .....	329.95	382.95
	SR Low DS Alt/Pass Air Bracket Kit - 2 brackets w/adj bars(Vette) .....	393.95	431.95
	SR Low DS Alt/Pass Air Bracket Kit - 2 brackets w/adj bars (IROC/TA) .....	393.95	431.95
	SR Style Idler Kit, low alt/air w/P/S - 4 idlers, 2 brackets (Vette) .....	398.95	463.95
	SR Style Idler Kit, low alt/air w/P/S - 4 idlers, 2 brackets (IROC/TA) .....	398.95	463.95
	SR Style Idler Kit, low alt/air w/o P/S - 4 idlers, 2 brackets (Vette) .....	398.95	463.95
	SR Style Idler Kit, low alt/air w/o P/S - 4 idlers, 2 brackets (IROC/TA) .....	398.95	463.95
	SR Power Steering - Pass High - bracket, pump & pulley (Vette) .....	302.95	322.95
	SR Power Steering - Pass High - bracket, pump & pulley (IROC/TA) .....	302.95	322.95
	SR Power Steering - Low DS - bracket, pump & pulley (Vette) .....	302.95	322.95
	SR Power Steering - Low DS - bracket, pump & pulley (IROC/TA) .....	302.95	322.95
	<b>Accessories</b>		
	10 o'clock small alternator (Vette Style & Low Driver Side) .....	355.95	398.95
	12 o'clock small alternator (Pass side low) .....	355.95	398.95
	2 o'clock small alternator (Tight Upper Pass. Side) .....	355.95	398.95
	Alum Alternator Fan - small .....	43.95	53.95
	Alum Serpentine Alternator Pulley .....	48.95	59.95
	508 Compressor R-12 Sanden Compressor .....	280.95	334.95
	508 Compressor 134A .....	280.95	334.95
	508 Type III A/C Front Cover .....	53.95	65.95
	Alum Power Steering Reservoir w/mounting bracket .....	135.95	168.95
	#6 AN Power Steering Pressure Fitting .....	17.95	-
	1/2" pipe to #8 AN for bottom of reservoir .....	17.95	-
	LS-1 Crank Cover (Vette) .....	81.95	97.95
	LS-1 Crank Cover (IROC/TA) .....	81.95	97.95
	A. Alum. Blower Drive Pulley (Specify Size) .....	118.95	140.95
	B. Smooth Blower Idler Pulley .....	70.95	81.95
	C. K&N Air Cleaner for Blower Application .....	\$57.95	-
	D. 3 Pin Mass Air Flow Adapter .....	48.95	59.95
	Mass Air Flow Core Charge .....	145.95	145.95
	E. 90 Degree Blower Elbow (MAF not included) .....	151.95	189.95
	F. 5 Pin Mass Air Flow Adapter .....	59.95	81.95
	<b>Small GM Alt includes core charge, alum fan, serpentine pulley.</b>		

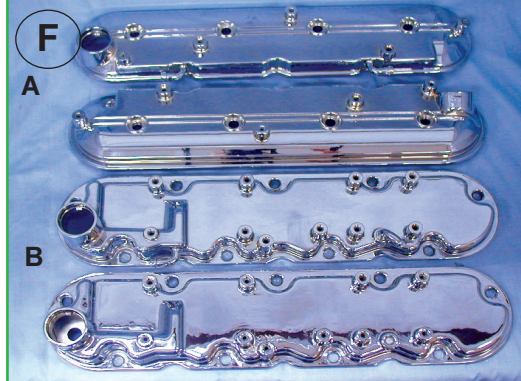

**LS-1 Factory Aluminum Valve Covers**  
We can polish or chrome your LS-1 Valve Covers on an exchange basis. A = 99 -up and B = 97 & 98.  
Pair - polished ..... \$ 151.95  
Pair - Chrome ..... \$ 285.95

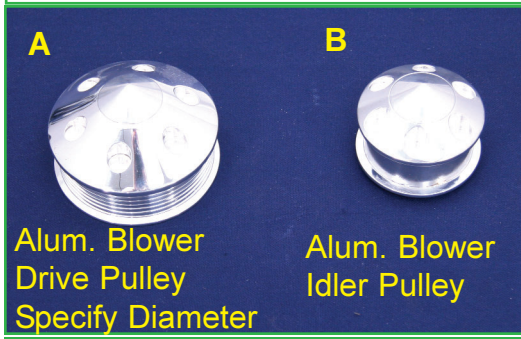



### LS-7 Headers

All Street & Performance LS-7 Headers have 3/8" Stainless Steel Head Flanges and Collector Flanges for better gasket sealing. Headers come complete with bolts and Street & Performance special design gaskets which have a thin layer of metal between the material. All Headers are available plain steel or thermo coated inside and out.

Street Rod Headers - Plain . . . . .	529.95
Street Rod Headers - Thermo Coated. . . . .	654.95
Street Rod Tight Tuck - Plain . . . . .	519.95
Street Rod Tight Tuck - Thermo Coated. . . . .	637.95
54-96 Vette Headers - Plain . . . . .	548.95
54-96 Vette Headers - Thermo Coated. . . . .	658.95
55 - 57 Headers - Plain . . . . .	529.95
55 - 57 Headers - Thermo Coated. . . . .	654.95
58 - 64 Chevy Headers - Plain . . . . .	529.95
58 - 64 Chevy Headers - Thermo Coated. . . . .	654.95
67-69 Camaro- Plain . . . . .	567.95
67-69 Camaro- Thermo Coated. . . . .	680.95
G-Body Headers-Plain . . . . .	567.95
G-Body Headers-Thermo Coated . . . . .	680.95
Nova Type III Style Header- Plain). . . . .	551.95
Nova Type III Style Header- Coated . . . . .	680.95
Other Designs are also available. Call for Info.	
O2 Sensor (ea) . . . . .	78.95
O2 Simulators (ea) . . . . .	83.95
Steel Bun only (ea) . . . . .	19.95
Replacement Flange Gaskets (ea) . . . . .	16.95
Replacement Collector Gasket (ea) . . . . .	7.95
Polished Stainless Collectors w/O2 (ea) . . . . .	94.95

### LS-7 Vette / Street Rod



LS-7 Camaro / G-Body Chromex Coated Headers Available with 2 1/2" or 3" Collectors

### VIBRATION PROOF LOCK WASHERS set of 12 \$20.95

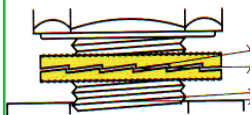

### LS-7 TIGHT TUCK HEADERS

Chromex Coated Inside & Out  
All S&P Headers come complete with bolts, gaskets and collectors

### 8.1 DBW Gas Pedal

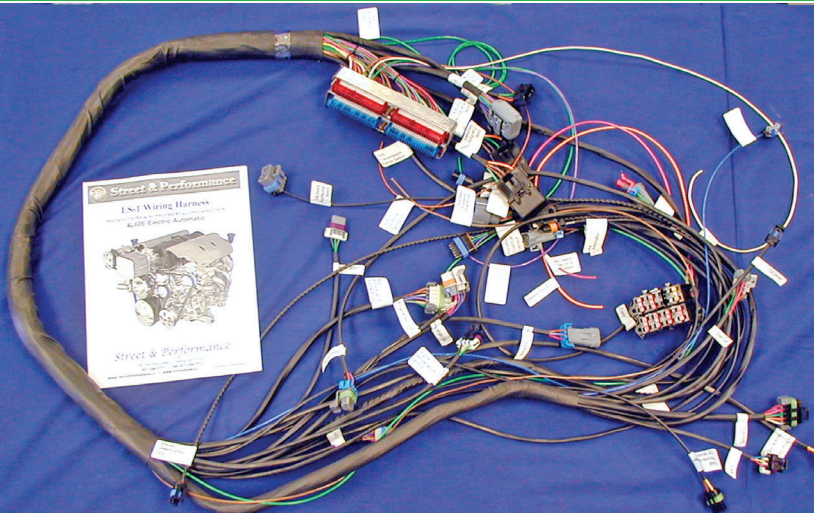

**NEW 8.1 Big Block Chevy**  
with or without 4L80E & Allison Transmission  
Easy 4 wire Hook-up (Plug and Go) \$983.95  
With Allison Transmission, Add \$310.95



58 Tooth Reluctor Ring Computer  
 \$341.95 12597121

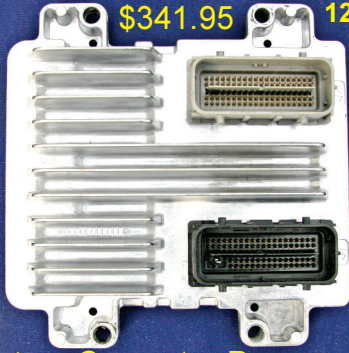

Custom Computer Programming  
 \$414.95



LS-7 Mass Air Flow Sensor  
 \$ 80.95

LS-2  
 5 Pin  
 MASS  
 AIR  
 FLOW  
 \$202.95



05 up Drive by Wire Gas Pedal



1. 05 up Corvette Gas Pedal. . . . . \$129.95
2. 05-06 SSR Gas Pedal. . . . . \$
3. 05-06 GTO Gas Pedal. . . . . \$297.95
4. Lokar GTO Gas Pedal Pad. . . . . \$ 72.95

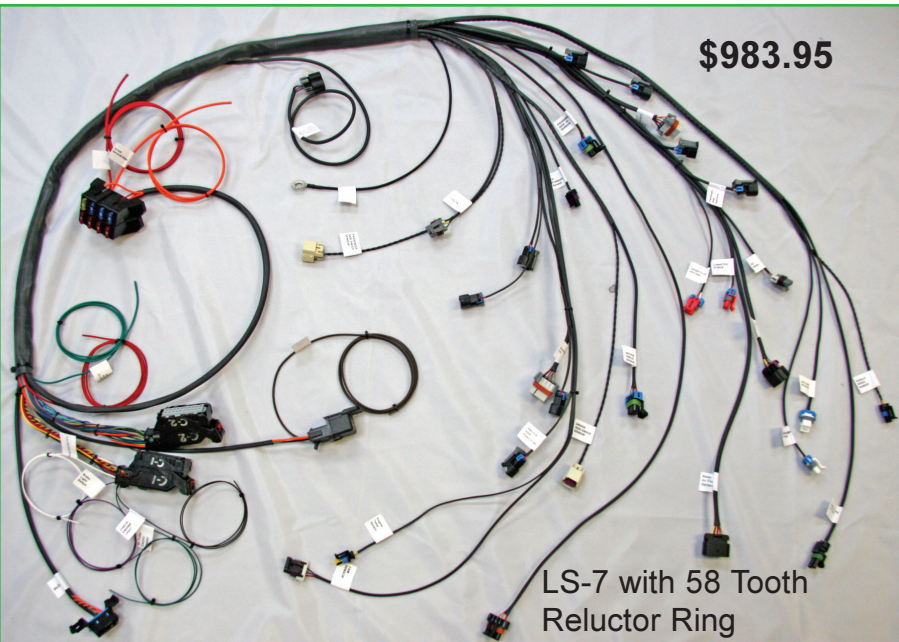

\$983.95

LS-7 with 58 Tooth  
 Reluctor Ring

LS-7 Engine Wiring Harness for Man/Auto transmission (DBW) using the 12597121 Computer and 05 up Vette gas pedal. Uses LS-7 Mass Air Flow. Harness comes with fuse block, relays and diagnostic link. Easy four wire hook up. Included with easy to follow instruction sheet. (Auto trans control module needed and reprogrammed for gear ratio and tire diameter)

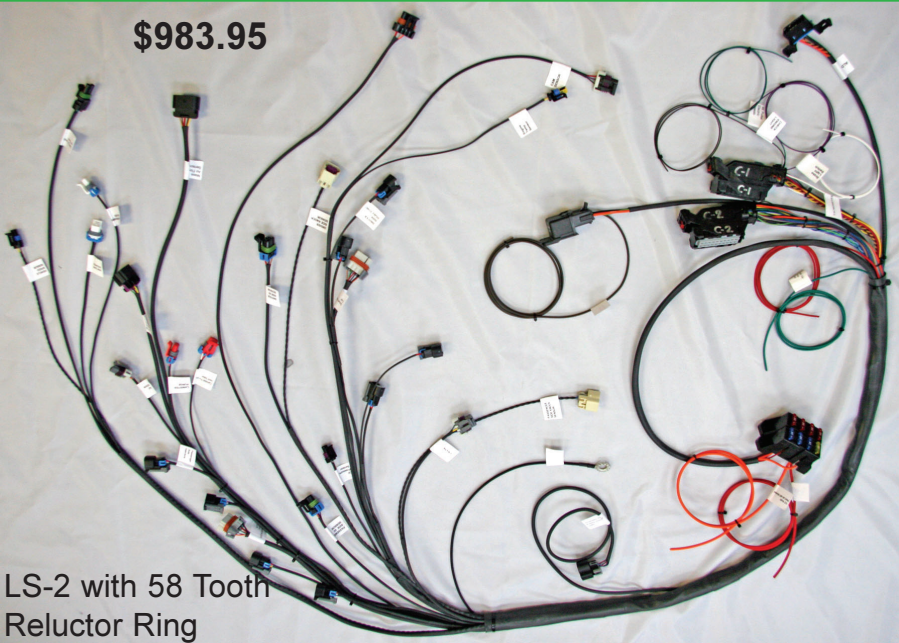

\$983.95

LS-2 with 58 Tooth  
 Reluctor Ring

LS-2 Engine Wiring Harness for Man/Auto transmission (DBW) using the 12597121 Computer and 05 up Vette gas pedal. LS-2 uses an 5 pin Mass Air Flow. Harness comes with fuse block, relays and diagnostic link. Easy four wire hook up. Included with easy to follow instruction sheet and 7 day a week tech help. (Auto trans control module needed and reprogrammed for gear ratio and tire diameter)

If you have a 5 pin Mass Air Flow you can send it in and we can machine it to our air Filter as shown to the right. The LS2 air cleaner has the PCV fitting.

LS-2  
 5 Pin MASS AIR FLOW

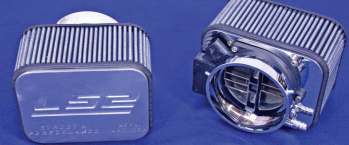



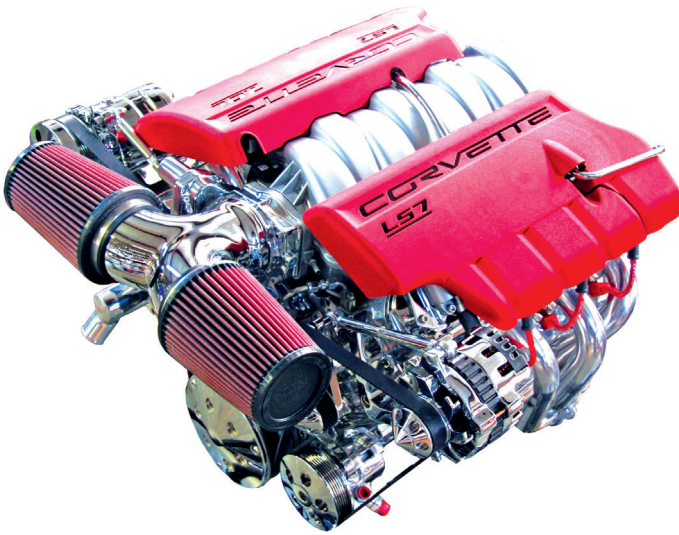

**LS-7 with Wide Style Brackets  
for early Vettes & 50's Up.**

For Brackets see page 86 Photo B. Pricing on page 87.

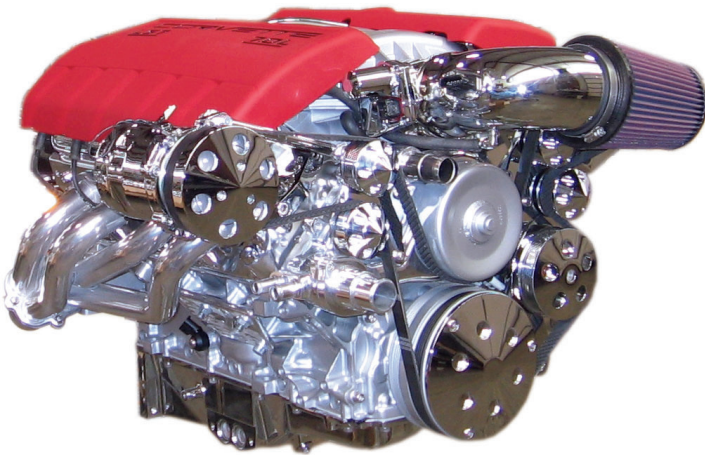

**Mass Air Flow Integrated 90 Degree Elbow on  
LS-7 with Vette/Camaro Style Brackets  
(MAF and K&N Filter Optional)**

Part#	Mass Air Flow Integrated Elbow	Natural	Polished	Chrome
	Mass Air Flow Integrated Elbow(Single DS 90)	165.95	199.95	248.95
	Mass Air Flow Integrated Elbow(Single PS 90)	165.95	199.95	248.95
	Mass Air Flow Integrated Elbow(Twin 90)	258.95	295.95	372.95
	LS-7 MASS AIR FLOW Unit	80.95	-	-
	K&N Air Cleaner	57.95	-	-
	PCV Fitting	16.95	N/A	19.95

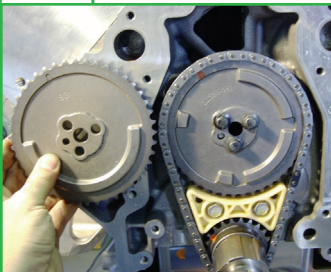

Shown is the 24 tooth reluctor ring cam gear and the 58 tooth cam gear. Converting a 58 tooth reluctor ring to a 24 tooth reluctor ring, the cam gear must also be changed.

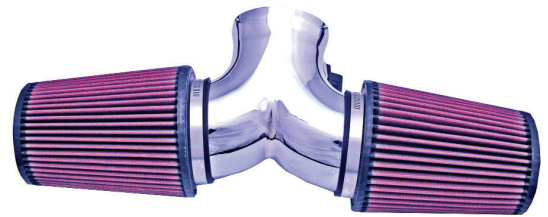

LS-7 Twin Air Horn with Provisions for Mass Air Flow Sensor and PVC fitting. Pol. \$306.95 Chrome \$372.95 Filter Elements add \$57.95ea.



**\$134.95**

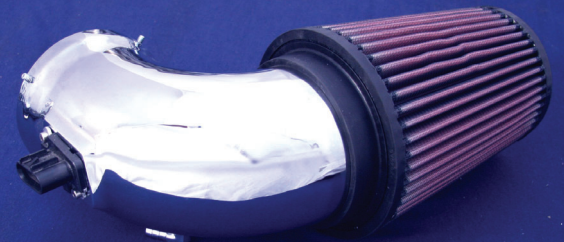

LS-7 Single Air Horn with Provisions for Mass Air Flow Sensor and PCV fitting. Pol. \$ 206.95 Chrome \$ 248.95 Filter Elements add.....\$57.95 ea.

**2 MAF RUBBER COUPLERS  
with Clamps**



- 1. 3 Pin MAF \$ 47.95
- 2. 5 Pin MAF \$ 47.95
- 3. 4" Coupler \$ 26.95

90 Degree Aluminum Elbow with Couplers and Clamps





**A**  
Driver Alt / Pass AC  
Low Driver PS  
LS2/LS7



**E**  
Low Driver Alt  
Low Pass. AC  
Upper Pass PS

Individual Part Pricing Page 101

**TRANSMISSION TAIL HOUSINGS**

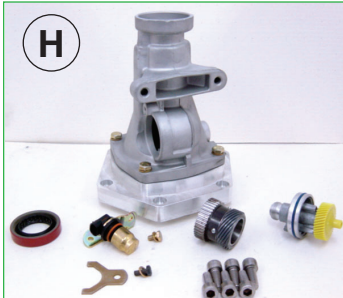

**H**  
96-Up 4L60E 6 Bolt to 4 Bolt Tail Housing Adapter. Comes with tail housing gears and hardware  
For Manual Speedometer. \$513.95  
Gear ratio and tire rollout is needed when ordering.

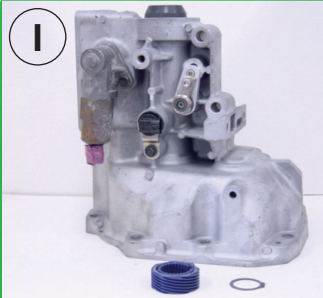

**I**  
T-56 6-Speed Manual Tail Housing Kit. Comes with gear and hardware on exchange basis  
For Manual Speedometer. \$523.95  
Gear ratio and tire rollout is needed when ordering.

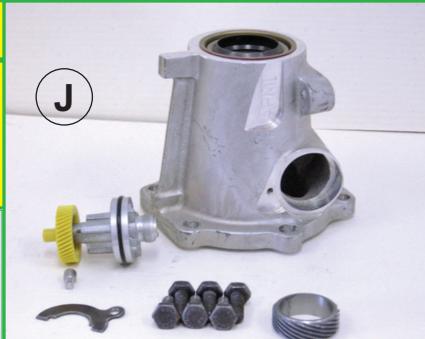

**J**  
4L80E Manual Speedometer Tail Housing Kit Complete.  
\$492.95



Heavy Duty GEN III Flex Plate for 4L60E, 4L65E and 4L70E Transmissions  
\$137.95

Should have a New Tightening Bolt when Replacing Balancers. Tighten to 110 ft lbs. Then back off bolt one turn. Retighten to 35 ft lbs and then turn bolt a additional 140 degrees.



**K**  
Dished Flex Plate (4) for a 4L60E Transmission and Flat Flex Plate (5) for early 4L60, R4, THM 400, THM 350  
**S&P Has New and Used 6 Speeds in Stock**

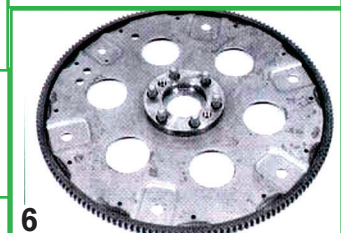

**6**  
This Flex Plate is used for a 4L80E transmission or a 6 Lug Converter. Flex Plate is Flat and Requires a Special Spacer

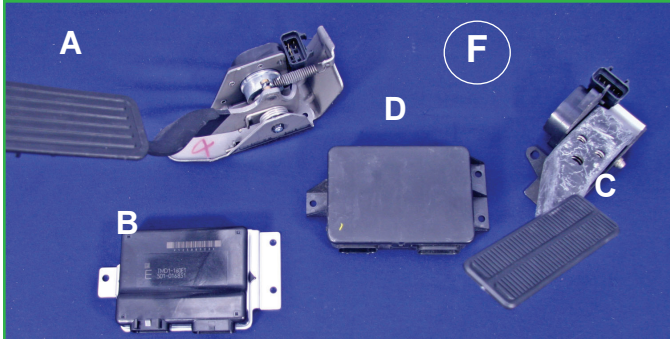

**DRIVE BY WIRE PEDALS & MODULES**

- A. Truck/SUV Throttle Pedal. (12177923)
- B. Truck/SUV Tac Module (05-12588923\* 03-05-12573059\* 02-12574221)
- C. 97-04 Vette Throttle Pedal. (12565643)
- D. 97-04 Vette Tac Module (12578953)

Part #	GEN III Accessories	Price
12560115	1. Corvette Balancer .....	\$157.95\$1
12553118	2. IROC/TA Balancer .....	18.95
12576652	3. C/K Truck .....	\$142.95
12580709	4. IROC/TA Flex Plate (4L60E) .....	\$136.95
12551367	5. Flex Plate for 4L60E, 700R4, 400-350 .....	\$142.95
12553332	6. Flex Plate Bolts (6 required) ea .....	\$1.95
12561680	7. Early Style 4 Speed Flywheel (not Pictured) .	\$386.95
12557583	8. Special Pilot Bearing for Above 4 Speed ....	\$19.95
12581650	9. 6 Speed Flywheel Assembly .....	\$588.95
12551367	10. 4L80E Flex Plate (Requires Spacer Below) .....	\$142.95
12563532	11. 4L80E Spacer .....	\$46.95
12563533	12. Bolt for 4L80E (6 Required) ea .....	\$10.95
12560344	13. Factory IROC Spring Tensioner .....	\$86.95